



City of Vancouver *Planning - By-law Administration Bulletins*

Community Services, 453 W. 12th Ave Vancouver, BC V5Y 1V4 ☎ 604.873.7000 fax 604.873.7060
planning@vancouver.ca

RS-1 EXPLANATORY NOTES

Authority - Director of Planning
Effective February 1992
Amended March 2004 and July 21, 2009

The following information is provided for your convenience and to help in understanding the provisions of the RS-1 Districts Schedule of the Zoning and Development By-law. It is intended only to complement the By-law; it does not form part of the By-law. Always refer to the By-law for complete information. Relevant section numbers of the District Schedule (unless otherwise indicated) follow topic title in brackets.

1 Height (Section 4.3)

Building height is regulated in two ways: an overall maximum height of 9.5 m or 2½ storeys, and, by a building envelope.

A **building envelope** defines a volume within which a building can be designed but does not dictate the actual form of the building. The building envelope is the three-dimensional representation of all provisions of the by-law combining height with all other required setbacks.

The following sketches illustrate the permitted building envelope for both houses and accessory buildings. Please note that the secondary or upper-level portion of the envelope need never be less than 9.8 m wide unless so restricted by required sideyards and it can be located anywhere between the required side yards. It is only more restrictive than the primary or lower-level portion of the envelope on lots wider than 12.2 m and narrower than 30.5 m.

Illustrated on 20.1 m lot

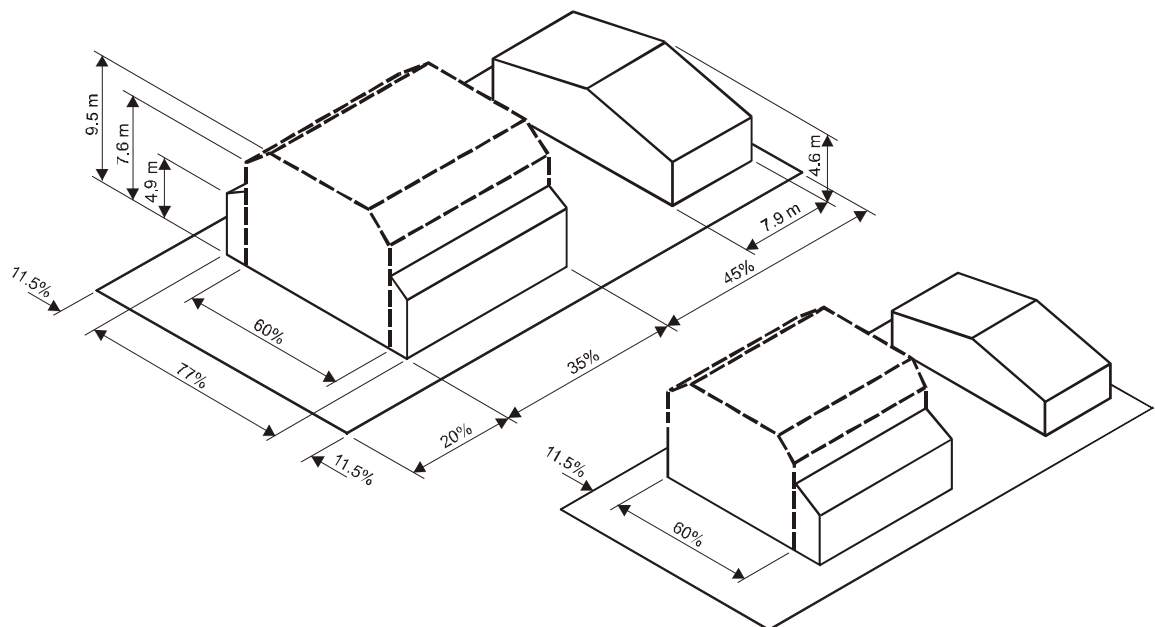

12.2 m x 37.2 m lot

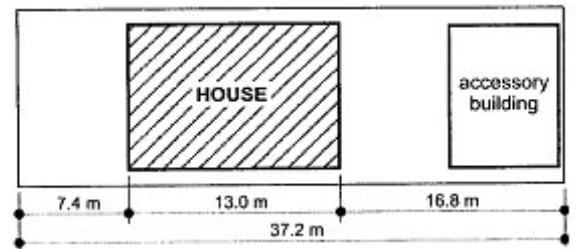
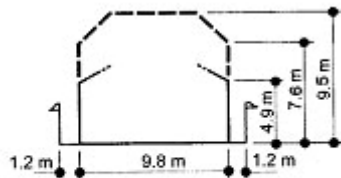

24.4 m x 37.2 m lot

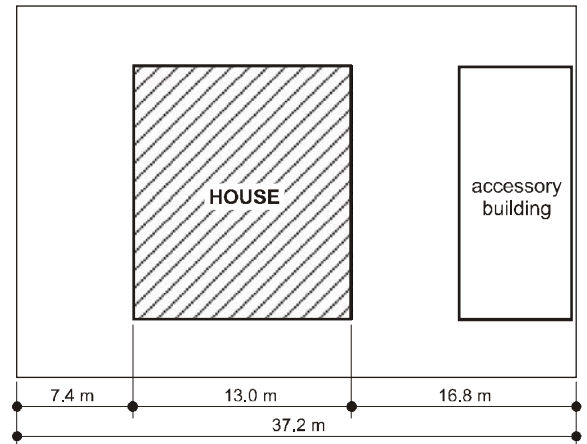
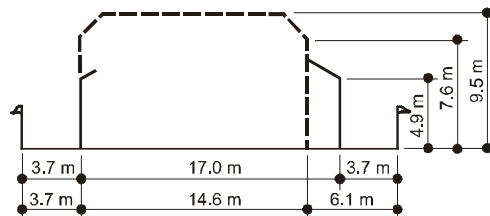
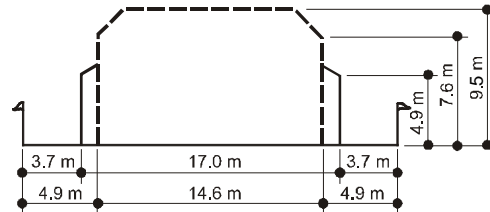

2 Relaxation of Height (Section 4.3.4)

The Director of Planning may permit a building to exceed a height of 9.5 m to a maximum of 10.7 m after consideration of:

- (a) the impact of the increased height on views from surrounding development;
- (b) the extent to which it would improve the roof lines of the building; and
- (c) the effect on adjacent properties and the character of the area.

In order to request such a relaxation, an applicant must submit the following additional materials:

- (a) view analysis showing how views would be affected by the increased height;
- (b) elevations of the proposed building;
- (c) front elevation of the proposed and adjacent buildings at a consistent scale;
- (d) photoboard of the block face of the proposed building; and

- (e) shadow impact drawing, such as the illustration here, showing the impact of shadowing at 9.5 m and also at the proposed height.

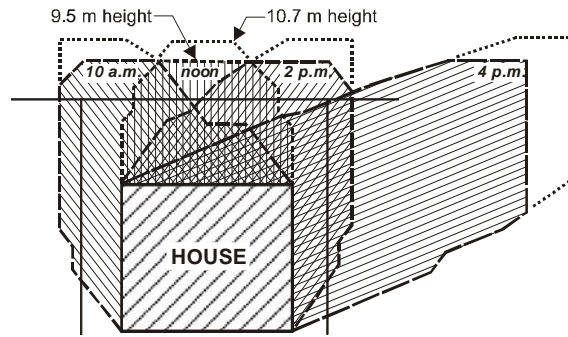

3 Yards (Sections 4.4 and 4.6)

This sketch illustrates the required yard setbacks and permitted building depth, expressed as percentages of site dimensions. Please note that a section following explains side yard calculations.

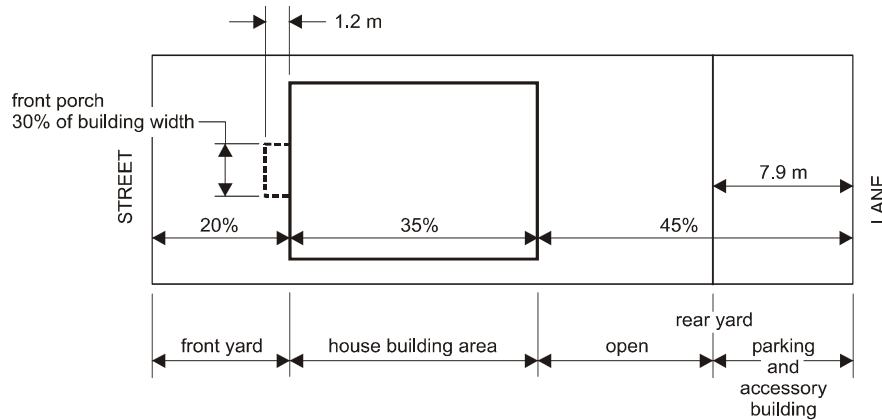

Covered porches are permitted to extend to 1.2 m into the required front yard for up to 30 percent of the building width.

Parking and accessory structures (garages and storage sheds) must usually be located within 7.9 m of the **ultimate** rear property line (refer to Section 2.2.A, and, to Section 4.6.1 of the Parking By-law). Ultimate refers to the line where the property line would be after any future required lane widening to achieve a standard 6.1 m wide lane.

4 Front Yard Averaging (Section 4.4.1)

Where the average front yard depth of the two adjacent houses on each side of a site is more than the required 20 percent depth by at least 1.5 m, or is less than 20 percent depth, the minimum depth of front yard to be provided will be that average (refer to conditions in By-law).

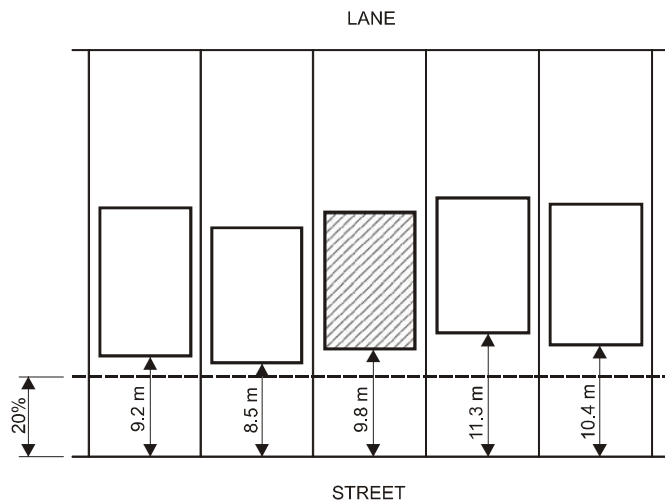

5 Rear Yard Compatibility (Section 4.6.1)

The rear yard may be reduced to equal the rear yard of the house on either side with the deeper yard (refer to conditions in By-law).

The rear yard for houses built prior to April 12, 1988 may be reduced by up to 3.1 m to permit additions provided that the total resulting depth of building does not exceed 35 percent. (Section 4.6.4).

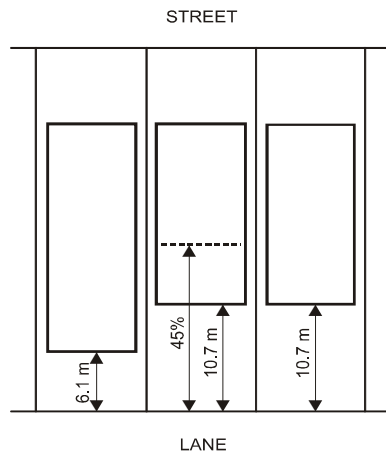

6 Side Yards (Section 4.5.1)

The required minimum for each side yard is determined by multiplying the site width by the percent of site width calculated by this formula:

$$\frac{\text{side width in metres} - (5)}{1.219} = \% \text{ of site width}$$

Except this percent shall never be less than 10 percent so the percent for side yards on all lots 18.3 m and less is 10 percent, and, the percent needs never be more than 20 percent so the percent for side yards on all lots 30.5 m or wider is 20 percent.

Site Width m/(ft)	Each Side Yard (%)	Each Side Yard m/(ft)
10.058 (33)	10.0	1.0 (3.3)
12.192 (40)	10.0	1.2 (4.0)
15.24 (50)	10.0	1.5 (5.0)
18.288 (60)	10.0	1.8 (6.0)
20.117 (66)	11.5	2.3 (7.6)
21.336 (70)	12.5	2.7 (8.8)
22.86 (75)	13.8	3.2 (10.3)
24.384 (80)	15.0	3.7 (12.0)
27.432 (90)	17.5	4.8 (15.8)
30.48 (100)	20.0	6.1 (20.0)
36.576 (120)	20.0	7.3 (24.0)

7 Corner Flanking Lots

(Section 11.1 of the Zoning and Development By-law)

Certain special provisions apply to corner flanking lots. The term **corner flanking lot** refers to a lot on a corner whose rear yard flanks the front yard of the lot behind. Lots 1 and 4 on the accompanying illustration are both corner flanking lots.

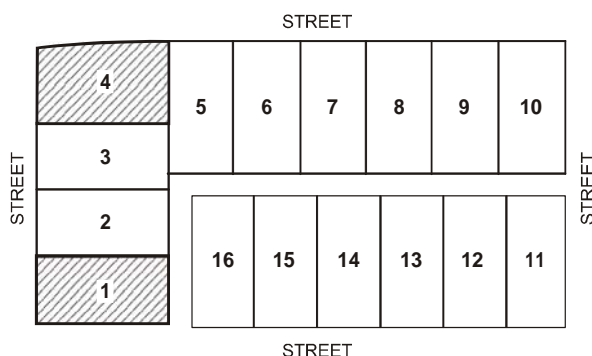

8 Floor Space Ratio (Section 4.7.1)

Floor space ratio means the figure obtained when the area of the floors of the buildings on a site is divided by the area of the site.

On each site, total maximum floor space ratio (FSR) is: $0.6 \times \text{site area}$

The maximum floor space ratio permitted **above the basement** is: $0.2 \times \text{site area} + 130 \text{ m}^2$

Therefore, the permitted FSR in the basement is: (**total** maximum FSR) - (**above-the-basement** FSR)

Floor areas having a ceiling height greater than 3.7 m will be counted as double in the calculation of FSR (refer to section 4.7.2). Parking is generally excluded from FSR calculations (refer to section 4.7.3).

FSR Example:

This site area of a **10.058 x 37.186 m** lot is **374.017 m²**. Therefore, the total maximum FSR is **0.6 x 374.017 = 224.410 m²**. The maximum floor space permitted above the basement would be **0.2 x 374.017 + 130 = 204.803 m²**. Therefore, if the maximum above-basement floor area is built, the maximum floor space that could be built in the basement is **224.410 - 204.803 = 19.6 m²**.

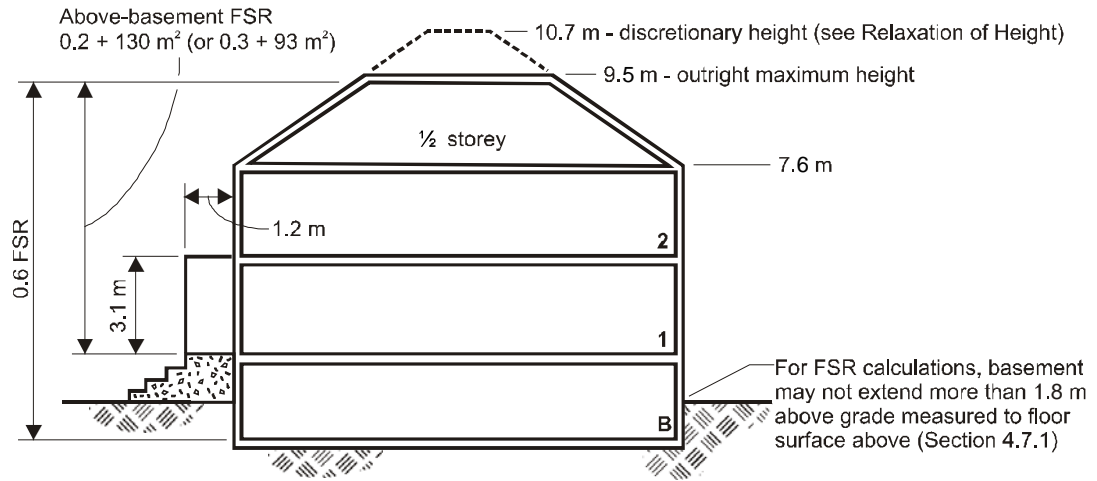

* Exception: A relaxation of above-the basement FSR on lots 18.2 m and wider with a minimum area of 500 m² may be possible to 0.3 + 93 m² subject to conditions in Section n 4.7.1 (c).

9 Site Coverage (Section 4.8)

Site coverage is the maximum area permitted to be covered by buildings, calculated as a percentage of the total area of a site.

The maximum site coverage permitted is 40% of the site area. This figure includes all accessory buildings on a site and covered porches but excludes steps, eaves, balconies and sundecks.

Site Coverage Example:

The site area of a **10.058 x 37.186 m** lot is **374.017 m²**. Therefore, the maximum area permitted to be covered by buildings is **0.4 x 374.017 = 149.607 m²**. The maximum house building area is **(37.186 m lot length x 0.35 = 13.015 m) x (10.058 m lot width - 2 x 1.0 m req'd side yard = 8.058 m) = 104.876 m²**. If the largest possible permitted covered porch is built into the required front yard for a total area of **(1.2 m deep) x (8.047 m building width x 0.3 = 2.414 m) = 2.897 m²**, therefore a garage or other accessory building(s) could be built in the rear 7.9 m of the rear yard up to an area covering **149.607 - 104.876 - 2.897 = 41.8 m²**.