

File No.: 2026-113

February 26, 2026

s.22(1)

Dear s.22(1)

Re: **Request for Access to Records under the Freedom of Information and Protection of Privacy Act (the "Act")**

I am responding to your request of February 2, 2026 under the *Freedom of Information and Protection of Privacy Act* for:

**Record of the date that the No Left Turn signs were installed for the West direction turning left from Main Street into 6th Avenue.**

All responsive records are attached. Some information in the records has been severed (blacked out) under s.15(1) and s.22(1) of the Act. You can read or download these sections here: [http://www.bclaws.ca/EPLibraries/bclaws\\_new/document/ID/freeside/96165\\_00](http://www.bclaws.ca/EPLibraries/bclaws_new/document/ID/freeside/96165_00).

Please note, Traffic & Data Management staff have advised that the signs referenced in your request were installed on September 25, 2024, as indicated in the attached responsive records.

Under Part 5 of the Act, you may ask the Information & Privacy Commissioner to review any matter related to the City's response to your FOI request by writing to: Office of the Information & Privacy Commissioner, [info@oipc.bc.ca](mailto:info@oipc.bc.ca) or by phoning 250-387-5629.

If you request a review, please provide the Commissioner's office with: 1) the request number (2026-113); 2) a copy of this letter; 3) a copy of your original request; and 4) detailed reasons why you are seeking the review.

Yours truly,

Kevin Tuerlings, FOI Case Manager, for

*[Signed by Kevin Tuerlings]*

**Siân Madsen, MA, MAS**  
**Acting Director, Access to Information & Privacy**

If you have any questions, please email us at [foi@vancouver.ca](mailto:foi@vancouver.ca) and we will respond to you as soon as possible. You may also contact 3-1-1 (604-873-7000) if you require accommodation or do not have access to email.

Encl. (Response package)

:kt

# TDM Form 1 – Transportation Division Regulatory Changes



Design Acceptance & Approval to Install

Block / Street(s):	Main St & E 6 <sup>th</sup> Av	Form 1 VanDocs:	DOC/2024/056204
		Site Investigation(s):	DOC/2024/056207 DOC/2024/056208
Project/Program:	Install Interim Northbound Left Turn Prohibited Regs	Account:	CER-00286-AA
Drawing Type(s):	<input checked="" type="checkbox"/> Sign Plan <input type="checkbox"/> Geometric <input type="checkbox"/> Paint Plan		
Provincial Heritage Pre-Contact Site?*	<input type="checkbox"/> Yes <input checked="" type="checkbox"/> No		# 1857623

Issuance Log

CEM1857623

Revision	Revision	Drawing VanDocs	Date	Description of Revision
00	N/A	DOC/2024/056205	2024-06-24	Initial revision.

Design Rationale

Traffic and Data Management Branch (TDM) received multiple Hansen cases (SR#2224455, 2337212, 2337177, 2337135, 2337106, 2304058, 2301354, 2342691, 2342703, 2342684, 2342645) regarding northbound left turning vehicles on Main St and E 6<sup>th</sup> Av. When making this turn from a major arterial road to enter a stopped controlled local street, drivers and cyclists alike must cross 3 lanes of oncoming traffic at this unsignalized intersection. After reviewing the ICBC Crash Data and considering the potential effects it would have on neighboring intersections, TDM has proposed prohibiting left turns at E 6<sup>th</sup> Av for northbound traffic. In January 2023, Transportation Planning (TPL) ran an analysis on this proposal and found this ban may potentially push traffic to the next intersection at E 5<sup>th</sup> Av (a local street bikeway) controlled by a pedestrian and cyclist actuated traffic signal. TPL has long-term plans for the Main St & E 6<sup>th</sup> Av intersection, however as an interim solution, TPL agreed to let TDM install the Left Turn Prohibited signs (RB 12).

Scope

TDM will proceed with the installation of an interim side-mounted RB 12s while a decision is to be made for a future, new traffic signal at this location. The two RB 12 signs are to be installed on Pole 7/21 and 8/21 for the northbound traffic at the intersection of Main St and E 6<sup>th</sup> Av.

Request for Approval and Documentation

- This Form 1 seeks approval for the installation of permanent and temporary traffic control signs, which are consistent with the Manual Uniform Traffic Control Devices for Canada (MUTCD) 6<sup>th</sup> Edition.
- The proposed changes and/or addition to the existing regulations comply to the 'City of Vancouver Street & Traffic By-law No. 2849', which regulates traffic, the use of streets, and the size and weight of vehicles that are permitted to travel on City of Vancouver streets.
- The Sign Plan Drawing (DOC/2024/056205) conforms to the 'List of Regulations, Guidelines and Standards' as per the Organizational Quality Management (OQM) Quality Assurance Records.

RECEIVED  
AUG 27 2024  
BS.

Design Acceptance and Approval to Install

Signature	Approval Level	Signature, Date (YYYY-MM-DD)	Phone
Yes	Author	Jed Bautista, 2024-06-20	8-7989
Yes	Supervisor/Engineer of Record	Alipasha Larijani, 2024-06-26 / Laura Smith, 2024-02-07	8-5113 /
<input type="checkbox"/>	Parking Management		-
<input checked="" type="checkbox"/>	Traffic & Data Management	Winston Chou, 2024-07-03	-
<input type="checkbox"/>	Transportation Design		-
<input type="checkbox"/>	Transportation Planning	Paul Storer, 2024-07-31	-
<input type="checkbox"/>	Transit Integration and Projects		-
Yes	Director of Transportation		-

ENTERED

Operations

Installation by / coordinated with:

Traffic and Electrical Ops  Parking Ops  Other:

Instructions

Please install a side-mounted RB 12 on pole 7/21 and 8/21 for NB traffic. WD 11s to be installed on all four legs of the intersection and replace RB 58 sign on Pole 5/21 as per the approved traffic control sign plan: DOC/2024/056205.

Inventory

RB 12 x2	New Long Post & Sleeve x2	WD 11 x4	RB 58 -> x1
----------	---------------------------	----------	-------------

Installed by:	Date (YYYY-MM-DD)	Field Review by:	Date (YYYY-MM-DD)
Jeremiah Bathan	25 SEPT 2024	s.15(1), s.22(1)	2024/11/09
Installed per Design?	<input type="checkbox"/> Yes <input checked="" type="checkbox"/> No	Note changes and reasons on drawing or in instructions box above.	

Relocated 1x traffic pattern change from 4/2 4/22 to 6/22

due to

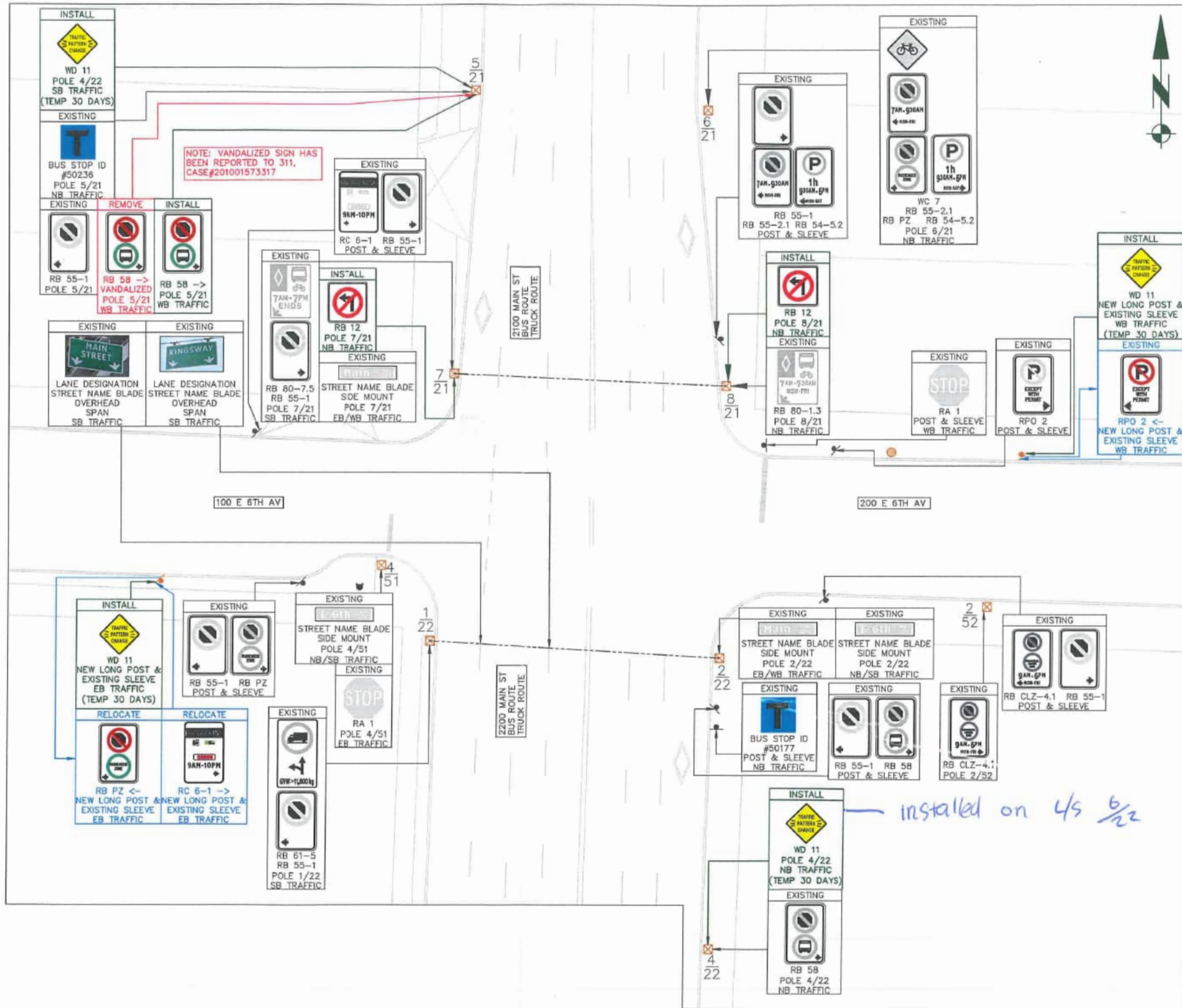

- TRAFFIC OPS. SIGN CODE INVENTORY
- RB 12
  - WD 11
  - RB 58
  - NEW LONG POST & EXISTING SLEEVE

**FINAL DRAWING**  
ISSUED FOR CONSTRUCTION

CHECKER: s.15(1), s.22(1)

SEAL: PROFESSIONAL ENGINEER L. J. SMITH #54850 s.15(1), s.22(1)

ENGINEERING SERVICES TRANSPORTATION DIVISION  
REFER TO FORM 1 FOR TRANSPORTATION DIVISION APPROVAL

INSTALL INTERIM NORTHBOUND LEFT TURN PROHIBITED SIGNS  
2100-2200 MAIN ST & 100-200 E 6TH AV  
SIGN PLAN

*installed on 4/5 6/2*

REV	DATE	BY	DESCRIPTION	STATUS	ENGINEER OF RECORD	DESIGNER	DRAFTER
00	2024-05-24	DOC/2024/059205			Leanne Smith	Jed Radtke	Jed Radtke
01		DWG/VANDOCES					

BIKE FACILITIES YES  NO  BUS ROUTE YES  NO  TRUCK ROUTE YES  NO  RAILWAY CROSSING YES  NO