

# BIORETENTION DESIGN NOTES AND GUIDANCE

**PURPOSE:**

BIORETENTION SYSTEMS RETAIN RAINWATER RUNOFF BY PROVIDING SURFACE, SUBSURFACE STORAGE AND INFILTRATION INTO NATIVE SOIL. WATER IS ALSO TREATED AS IT FILTERS THROUGH THE BIORETENTION SOIL.

THE FOLLOWING DRAWINGS ARE TEMPLATES FOR DESIGNING BIORETENTION SYSTEMS IN CITY OF VANCOUVER RIGHT-OF-WAYS. THE DRAWINGS CONTAIN THE COMPONENTS, MATERIALS, AND COMPOSITION REQUIRED FOR BEST PRACTICE BIORETENTION DESIGN. EACH DRAWING HAS VARIABLE DIMENSIONS WHICH MUST BE ADAPTED FOR SITE CONDITIONS AND SHOWN ON SITE DRAWINGS. IF A NUMERICAL DIMENSION IS PROVIDED, THE DIMENSION IS REQUIRED AT THE FIXED VALUE.

**DESIGNER NOTES & GUIDELINES:**

- THE DESIGNER MUST ADAPT PLAN AND SECTION DRAWINGS TO ADDRESS SITE-SPECIFIC CONDITIONS.
- BIORETENTION AREA, PONDING DEPTH, BIORETENTION SOIL DEPTH, AND AGGREGATE STORAGE DEPTH MUST BE SIZED TO MEET PROJECT HYDROLOGIC PERFORMANCE GOALS.
- PONDING AND BIORETENTION SOIL DRAWDOWN TIME (I.E., TIME FOR MAXIMUM SURFACE PONDING TO DRAIN THROUGH THE BIORETENTION SOIL AFTER THE END OF A STORM) RECOMMENDATIONS:
  - 24 HOUR MAXIMUM SURFACE PONDING DRAWDOWN
  - 72 HOUR MAXIMUM DRAWDOWN FOR BIORETENTION SOIL AND AGGREGATE STORAGE
- AN AGGREGATE COURSE IS REQUIRED UNDER THE BIORETENTION SOIL FOR ALL BIORETENTION SYSTEMS WHERE AN UNDERDRAIN IS REQUIRED TO MEET DRAWDOWN REQUIREMENTS.
- TO ENCOURAGE INFILTRATION AND EVEN PONDING, THE FACILITY SUBGRADE AND BIORETENTION SOIL GRADE SHOULD BE FLAT. MID-CELL WEIR WALLS MAY BE USED TO TERRACE FACILITIES TO PROVIDE SUFFICIENT PONDING FOR INSTALLATIONS WITH HIGHER ADJACENT ROAD SLOPES. DESIGNER MUST SPECIFY WEIR WALL HEIGHT AND SPACING.
- WHEN FACILITY CONSTRUCTION IMPACTS EXISTING SIDEWALK, ALL SAW CUTS MUST ADHERE TO CITY OF VANCOUVER REQUIREMENTS. SAW CUTS SHOULD BE ALONG SCORE LINES AND ANY DISTURBED SIDEWALK PANELS SHOULD BE REPLACED IN THEIR ENTIRETY.
- GI FACILITIES IN PUBLIC RIGHT OF WAY SHALL BE DESIGNED WITH A SAFE, DESIGNATED OVERLAND FLOW PATH TO THE STREET IN THE EVENT THAT THE OVERFLOW STRUCTURE IS OBSTRUCTED OR CLOGGED. THIS FLOW PATH SHOULD BE REFLECTED IN SITE GRADING AND LABELED ON GI DRAWINGS.
- THE DESIGNER MUST EVALUATE UTILITY SURVEYS FOR POTENTIAL UTILITY CROSSINGS OR CONFLICTS. MINIMUM UTILITY SETBACKS AND PROTECTION MEASURES MUST CONFORM TO CURRENT CITY OF VANCOUVER ASSET PROTECTION STANDARDS AND OTHER UTILITY PROVIDER REQUIREMENTS.
- BIORETENTION VEGETATION MUST BE SPECIFIED BY A DESIGN PROFESSIONAL AND IN ACCORDANCE WITH THE CITY OF VANCOUVER GREEN INFRASTRUCTURE PLANTING GUIDELINES.

RELATED DETAILS		
EDGE TREATMENTS	GI 3.5	GI 3.6
INLETS	GI 2.1	GI 2.6
UNDERDRAINS:	GI 3.7	
CHECK DAMS:	GI 4.7	
MONITORING WELL	GI 3.2	
CLEANOUTS	GI 3.4	
WEIRS AND SEDIMENT PAD	GI 4.5	GI 4.6
INSPECTION CHAMBERS	GI 3.3	
CATCHBASINS	GI 3.1	GI 3.8

RELATED SPECIFICATIONS	COV SPEC NO.
- BIORETENTION SYSTEMS	***
- BIORETENTION SOIL MIX	***
- AGGREGATES AND GRANULAR MATERIALS	31 05 17
- GEOSYNTHETICS	31 32 19

\*\*\*TEMPLATE ONLY. AVAILABLE UPON REQUEST FROM THE GII BRANCH.

**LAYOUT REQUIREMENTS:**

- REFER TO THE CITY OF VANCOUVER ACCESSIBILITY STRATEGY, STANDARD DRAWINGS AND CONSTRUCTION SPECIFICATIONS FOR RIGHT-OF-WAY, PARKING SPACE, AND ACCESSIBLE PATH REQUIREMENTS.
- LOCATE CURB CUTS AND GUTTER MODIFICATIONS TO AVOID CONFLICTS WITH ACCESSIBILITY REQUIREMENTS (E.G., LOCATE OUTSIDE OF CROSSWALKS).
- IDENTIFY ALL SIGN AND POST LOCATIONS WITHIN THE GI AREA AND ENSURE PROPER BACKFILL MATERIALS ARE PRESENT TO PROVIDE THE NECESSARY STRUCTURAL SUPPORT FOR ALL SIGN BASES.

**DESIGNER CHECKLIST (MUST SPECIFY, AS APPLICABLE):**

- BIORETENTION WIDTH AND LENGTH
- DEPTH OF PONDING
- DEPTH OF FREEBOARD
- DEPTH OF BIORETENTION SOIL
- DEPTH AND TYPE OF AGGREGATE STORAGE, IF ANY
- SURFACE ELEVATION (TOP OF BIORETENTION SOIL) AT UPSLOPE AND DOWNSLOPE ENDS OF FACILITY
- CONTROL POINTS AT EVERY PLANTER WALL CORNER AND POINT OF TANGENCY
- DIMENSIONS AND DISTANCE TO EVERY INLET, OUTLET, CHECK DAM, SIDEWALK NOTCH, ETC.
- ELEVATIONS OF EVERY INLET, OUTLET, STRUCTURE RIM AND INVERT, CHECK DAM, PLANTER WALL CORNER, AND SIDEWALK NOTCH
- TYPE AND DESIGN OF PLANTER COMPONENTS (E.G., EDGE TREATMENTS, INLETS/GUTTER MODIFICATIONS, UTILITY CROSSINGS, LINER, AND PLANTING DETAILS)

REV.	REVISION DATE	APPROVED

**BIORETENTION  
DESIGN NOTES AND GUIDANCE**

ISSUE DATE: FEBRUARY 2026  
APPROVED BY: N. MEAD-FOX

**BIORETENTION DRAWING DESCRIPTIONS**

GI4.0A	BIORETENTION DESIGN NOTES	THE BIORETENTION DESIGN NOTES PROVIDE GUIDANCE TO DESIGNERS ON HOW TO ADAPT THE TEMPLATE STANDARDS.
GI4.0B	BIORETENTION DRAWING DESCRIPTIONS	THIS DRAWING DESCRIBES THE PURPOSE AND INTENDED USE OF EACH BIORETENTION DRAWING.
GI4.1	BIORETENTION PROFILE	THE BIORETENTION PROFILE IS A TEMPLATE PROFILE SECTION OF A BIORETENTION SYSTEM. BIORETENTION SYSTEMS MAY VARY SIGNIFICANTLY IN THEIR LENGTH AND DEPTH, BUT GENERALLY SHOULD INCLUDE THE COMPONENTS AND MATERIALS SHOWN ON THE DRAWING.
GI4.2	BIORETENTION BULGE WITHOUT ADJACENT BOULEVARD	THIS STANDARD SHOWS THE PLAN VIEW, CROSS-SECTION, AND RECOMMENDED DESIGN NOTES FOR A BIORETENTION BULGE WHERE THE VEGETATED AREA CANNOT EXTEND INTO THE EXISTING BOULEVARD.
GI4.3	BIORETENTION BULGE WITH ADJACENT BOULEVARD	THIS STANDARD IS AN ALTERNATE DESIGN OF GI4.2. AND IS TO BE USED WHEN THE VEGETATED AREA OF THE CELL CAN EXTEND INTO THE BOULEVARD.
GI4.4	CURB CUT SEDIMENT BASIN	CURB CUT SEDIMENT PADS ARE USED TO COLLECT ROADWAY SEDIMENT AND PREVENT EROSION IN THE GI SYSTEM DURING MAJOR STORMS. ADDITIONAL DETAILS ON CURB CUT OPENINGS ARE INCLUDED IN GI2.1 THROUGH GI2.6.
GI4.5	STRAIGHTAWAY SEDIMENT BASIN	THE STRAIGHTAWAY SEDIMENT PAD IS AN ALTERNATE DESIGN FOR BIORETENTION CELL WHERE THE PRIMARY INLET FLOW PATH FOLLOWS THE DIRECTION OF THE EXISTING CURB.
GI4.6	SEDIMENT BASIN WEIR WALL	THIS STANDARD SHOWS THE STRUCTURAL REINFORCEMENT AND BASE MATERIALS FOR THE WEIRS THAT CONTAIN FLOW IN THE SEDIMENT PAD AREA.
GI4.7	CONCRETE CHECK DAM	BIORETENTION SYSTEMS SHOULD MAXIMIZE THE FLAT AREA OF THE CELL, ALSO REFERRED TO AS THE "PONDED AREA". CONCRETE CHECK DAMS ARE USED TO INCREASE THE PONDED SURFACE AREA WHEN THE ELEVATION CHANGE ALONG THE ADJACENT ROADWAY LEADS TO AN UNACCEPTABLY HIGH DROP AT THE UPSTREAM END OF THE CELL.

REV.	REVISION DATE	APPROVED

**BIORETENTION**  
**BIORETENTION DRAWING DESCRIPTIONS**

ISSUE DATE: FEBRUARY 2026  
APPROVED BY: N. MEAD-FOX

DRAWING No.

GI4.1

STANDARD DETAIL DRAWINGS  
ENGINEERING SERVICES - VANCOUVER, B.C.

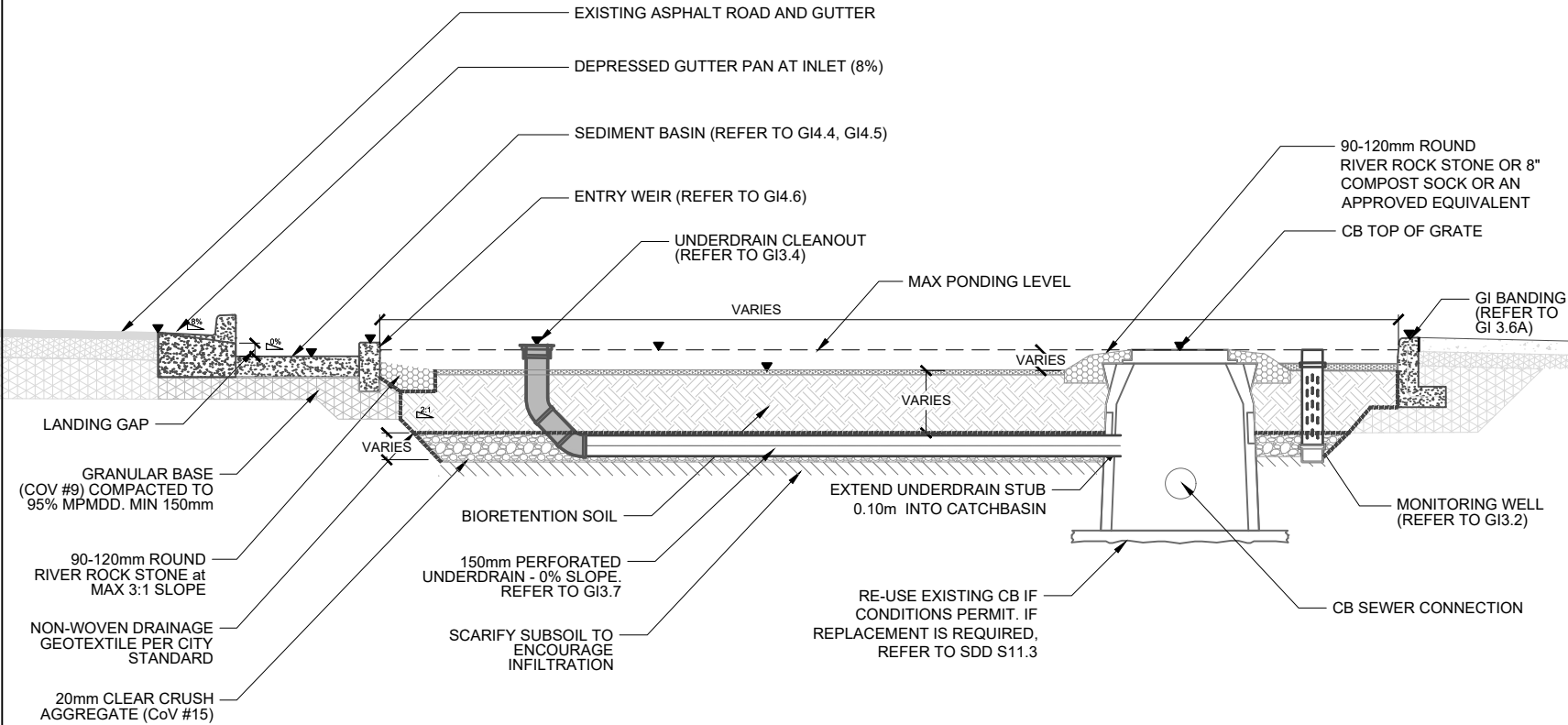

Cell Layer	Recommended Layer Thickness (m)
Composted Mulch	0.05-0.075
Bioretention Soil	0.45-1.00
Aggregate/Bedding	0.20-0.40
Geotextile	N/A

ISSUE DATE: FEBRUARY 2026  
APPROVED BY: N. MEAD-FOX

BIORETENTION  
BIORETENTION PROFILE

NOTES

1. LABEL AND DISPLAY ALL UTILITIES AND/OR SERVICES THAT CROSS BELOW OR THROUGH THE BIORETENTION PROFILE ALONG WITH THEIR OBVERT ELEVATIONS
2. SHOW ALL UTILITY PROTECTION MEASURES AND SETBACKS FOR SERVICES AND/OR UTILITY CONFLICTS
3. GRADING DESIGN SHOULD USE 3:1 SLOPES IN THE VEGETATED AREA TO MAXIMIZE THE FLAT AREA WITHIN THE SYSTEM THAT IS AVAILABLE FOR PONDING.
4. ▼ INDICATES ELEVATION POINTS THAT SHOULD BE SHOWN ON DESIGN DRAWINGS
5. THE CONTRACTOR IS TO PROVIDE PRE-SURVEY OF THE EXISTING CATCH BASIN (CB) CONDITIONS. THE PICTURES OF CBS ( INSIDE AND OUTSIDE ) , WELL ORGANIZED AND CORRELATED WITH THE CB LOCATION, ARE SUFFICIENT.
6. CORE OPENING IN THE EXISTING CB WALL TO SUIT PVC PERFORATED PIPE CONNECTION. GROUT ANNULAR OPENING AROUND THE PIPE WITH NON-SHRINK GROUT.
7. COV REPRESENTATIVE ( SEWER MAINTENANCE INSPECTOR) SHALL INSPECT AND APPROVE THE CONNECTION PRIOR TO THE PIPE BEING BURIED. CONTACT SEWERS AT 604-871-6170 TO ARRANGE FOR INSPECTION. PROVIDE AT LEAST 48 HOURS NOTIFICATION.
8. THE TOTAL DEPTH OF BIORETENTION SYSTEMS SHOULD NOT EXCEED 1.2m BELOW THE EXISTING GRADE.

REV	REVISION DATE	APPROVED

CONCEPTUAL AXONOMETRIC

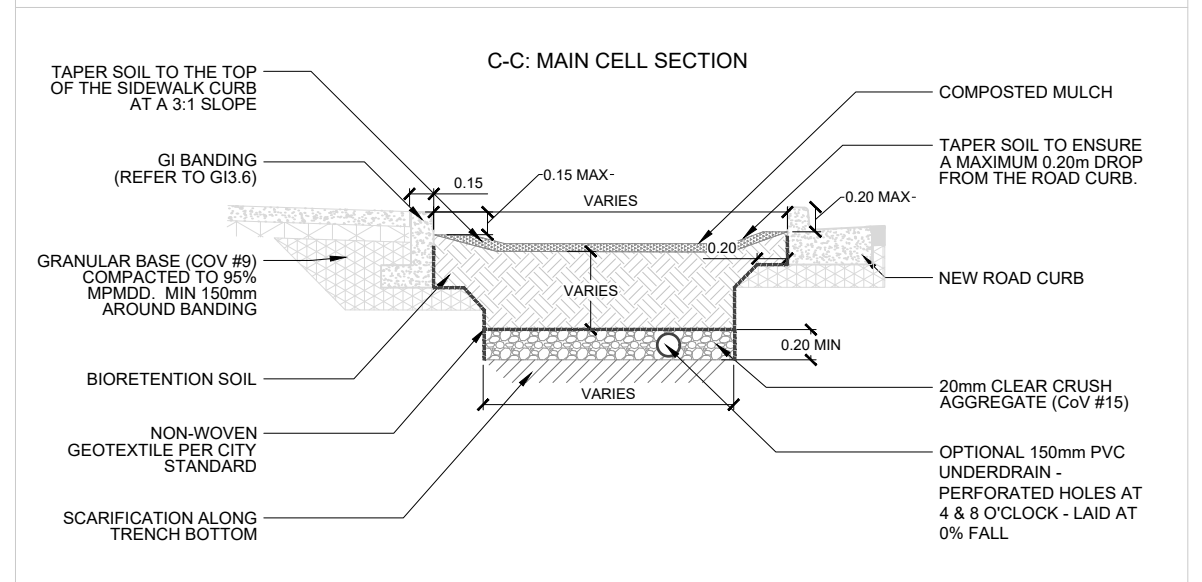
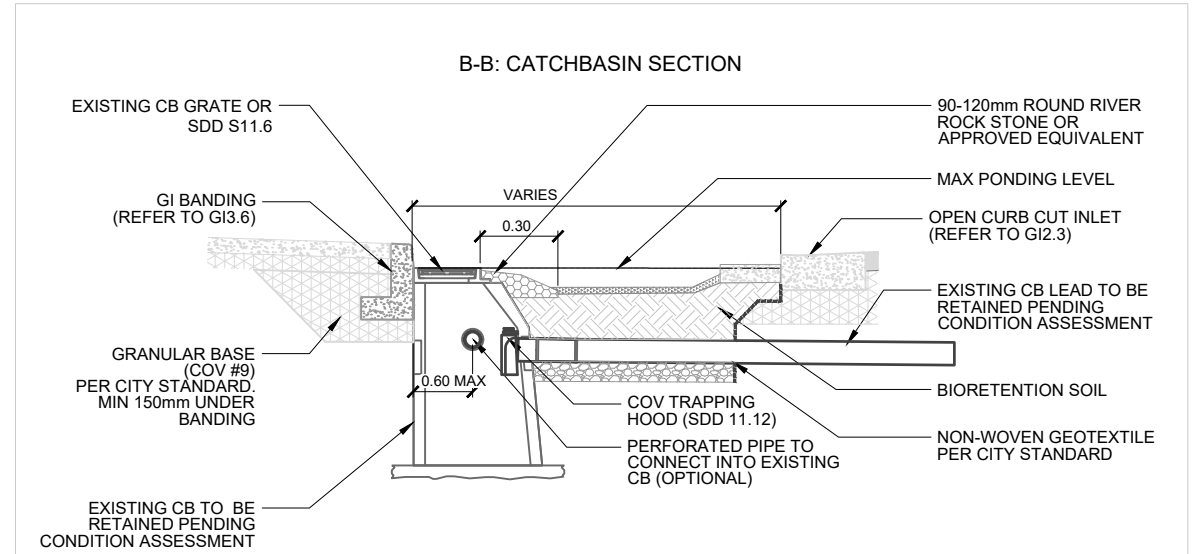
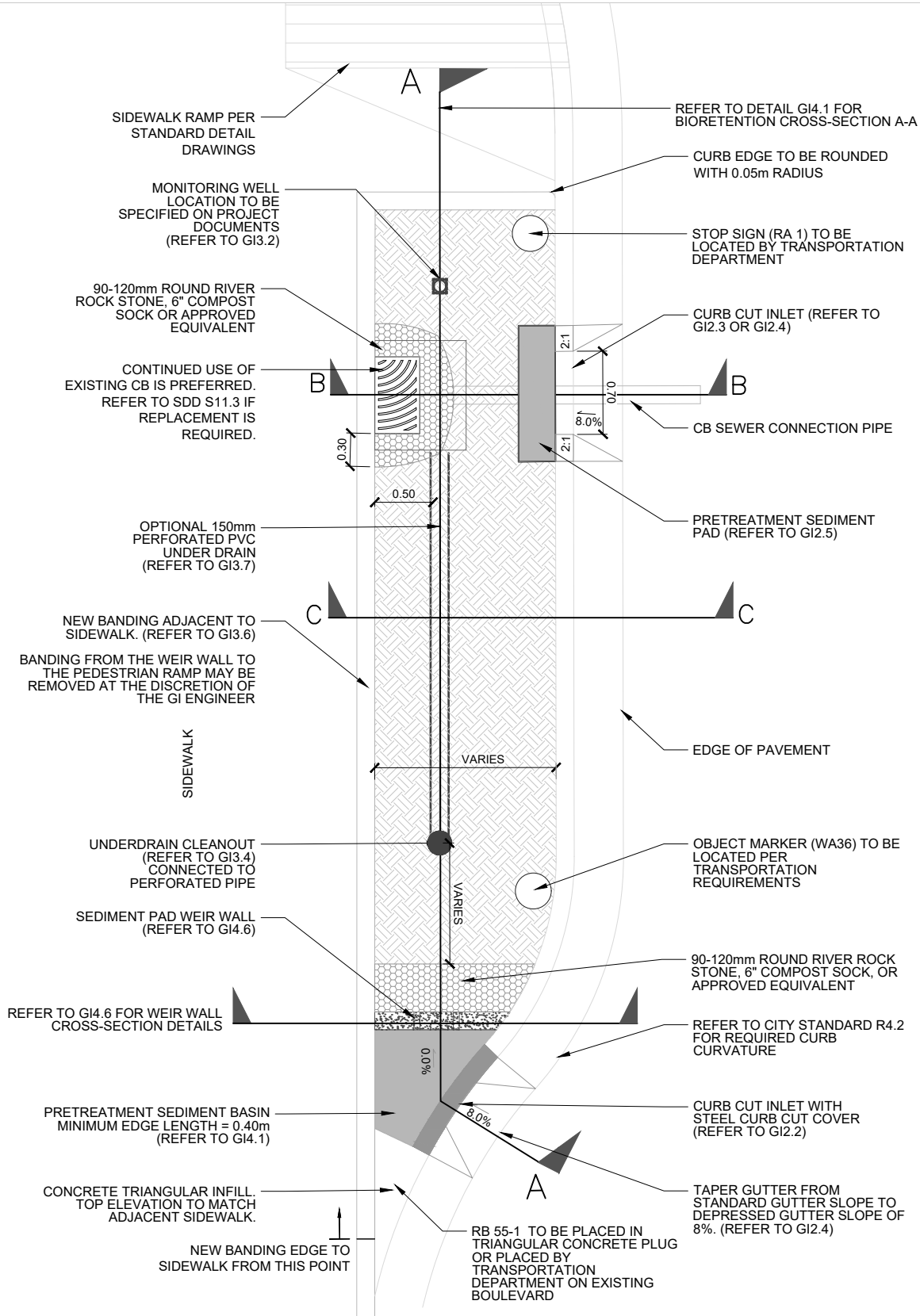
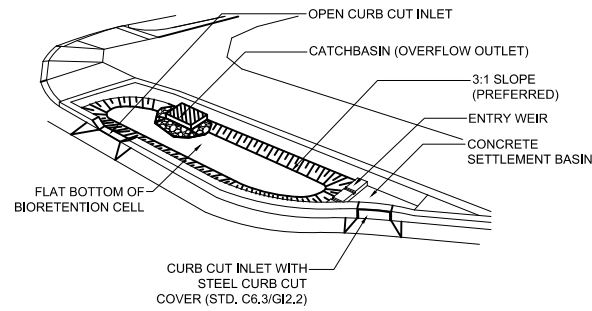

REV.	REVISION DATE	APPROVED

**BIORETENTION**  
**BIORETENTION BULGE WITHOUT ADJACENT BOULEVARD**

ISSUE DATE: FEBRUARY 2026  
APPROVED BY: N. MEAD-FOX

CONCEPTUAL AXONOMETRIC

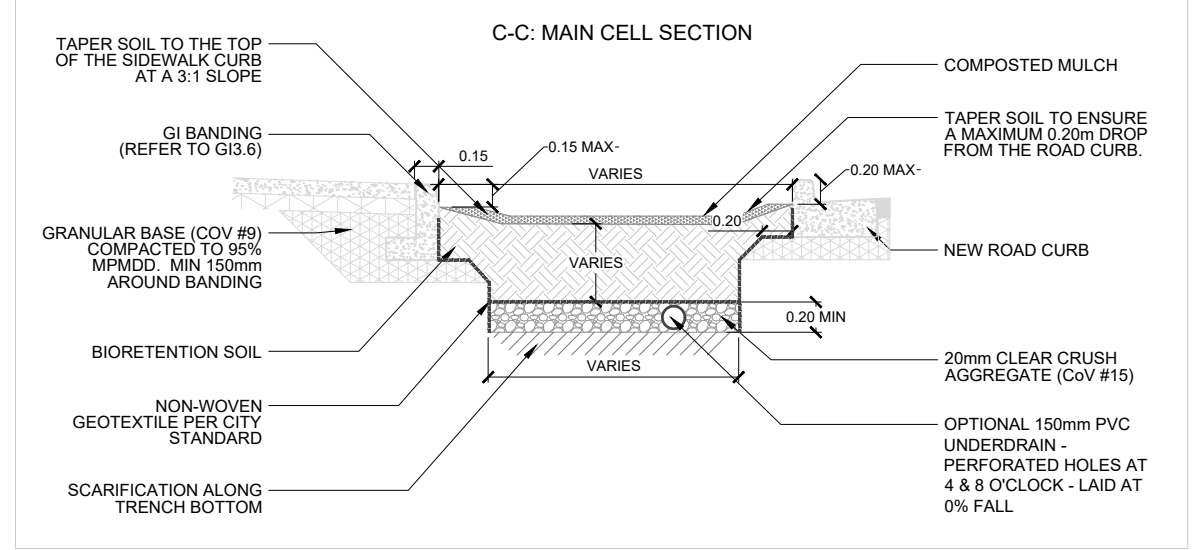
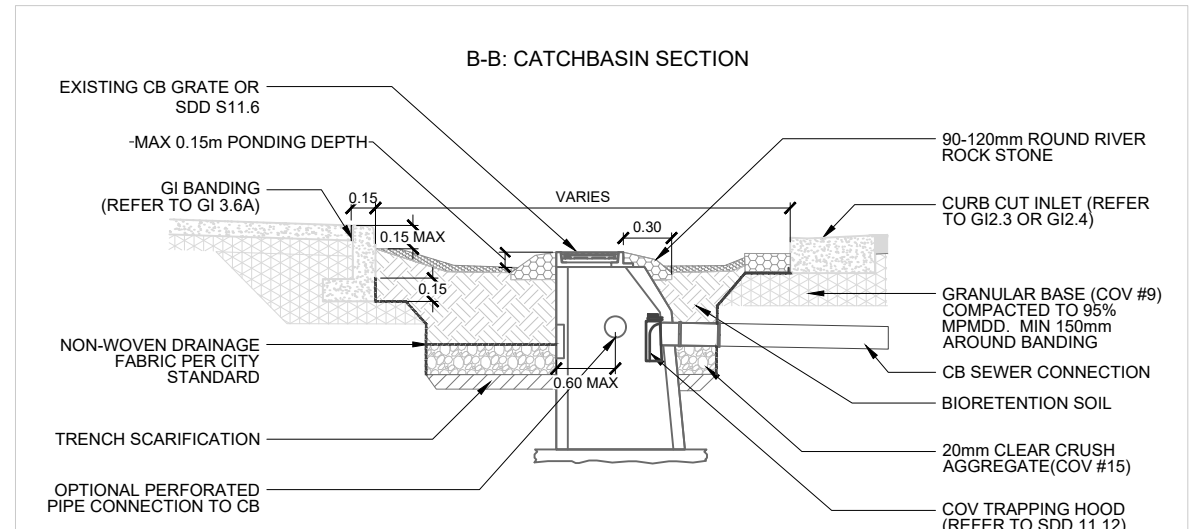
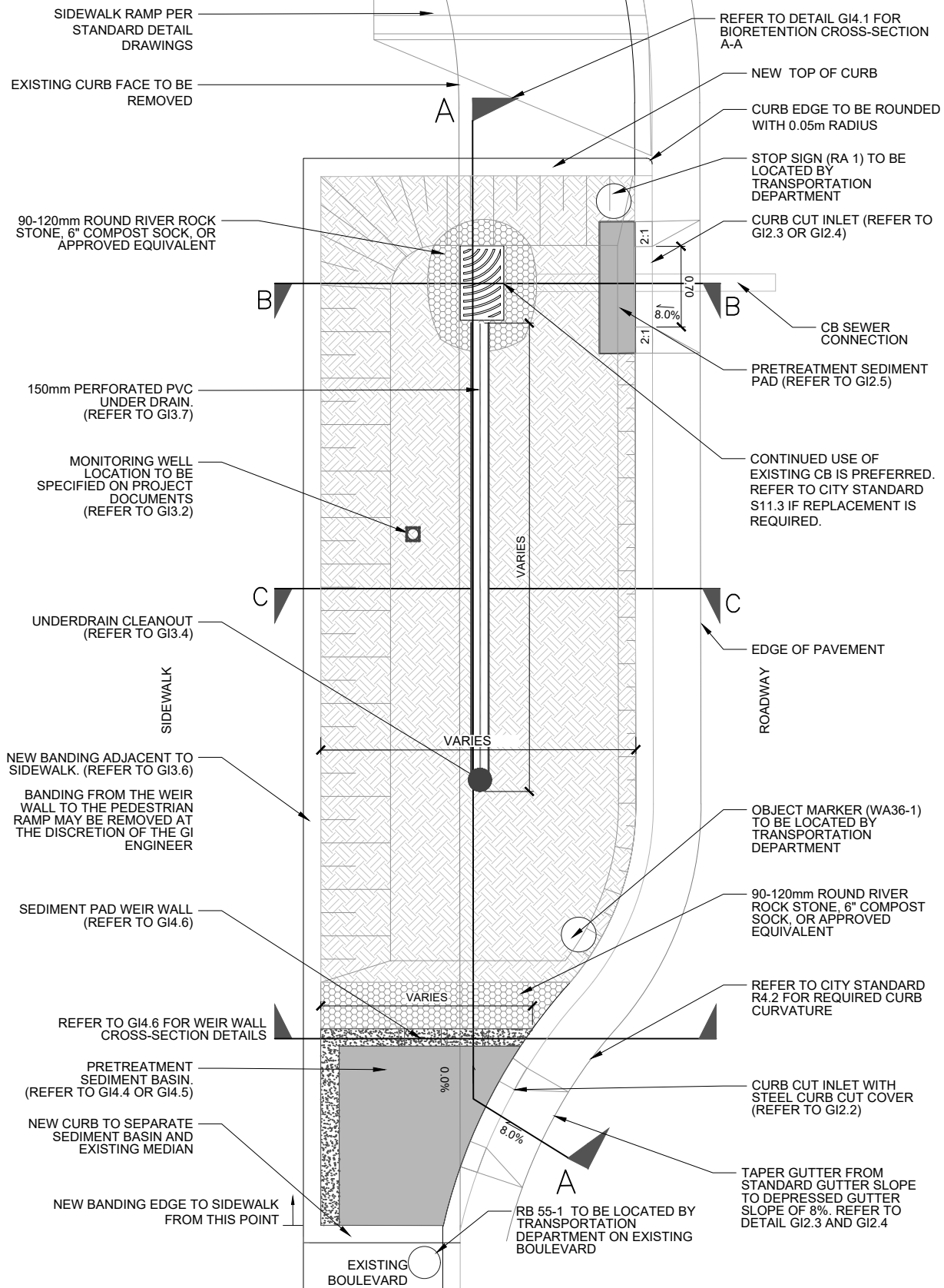
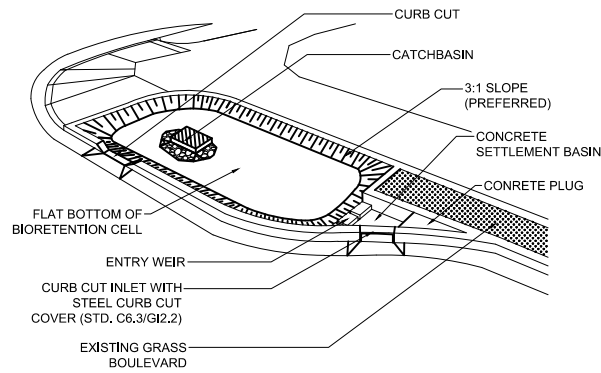

BIORETENTION  
BIORETENTION BULGE WITH ADJACENT BOULEVARD

ISSUE DATE: FEBRUARY 2026  
APPROVED BY: N. MEAD-FOX

REV.	REVISION DATE	APPROVED

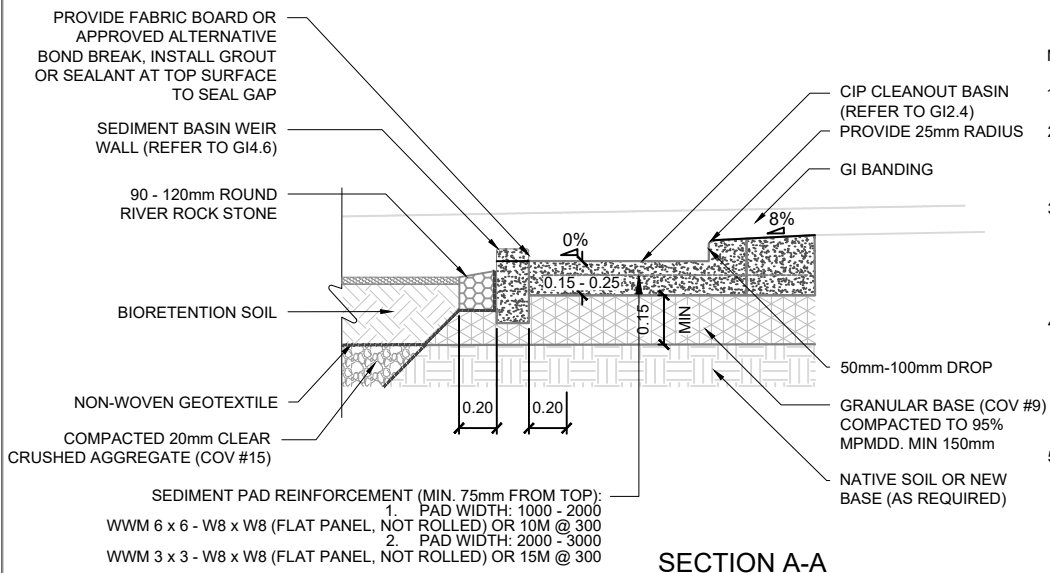
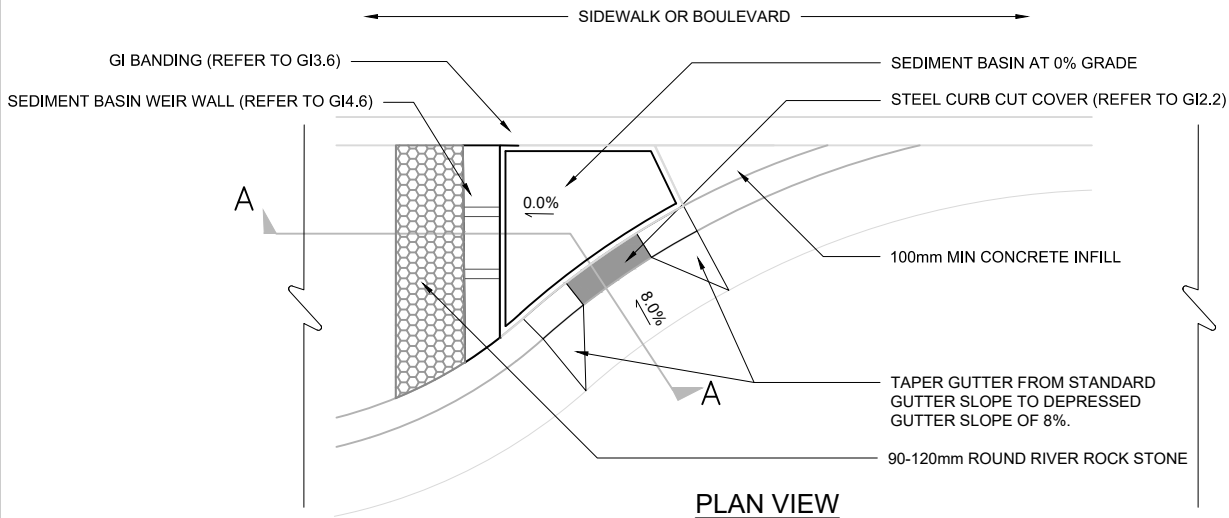
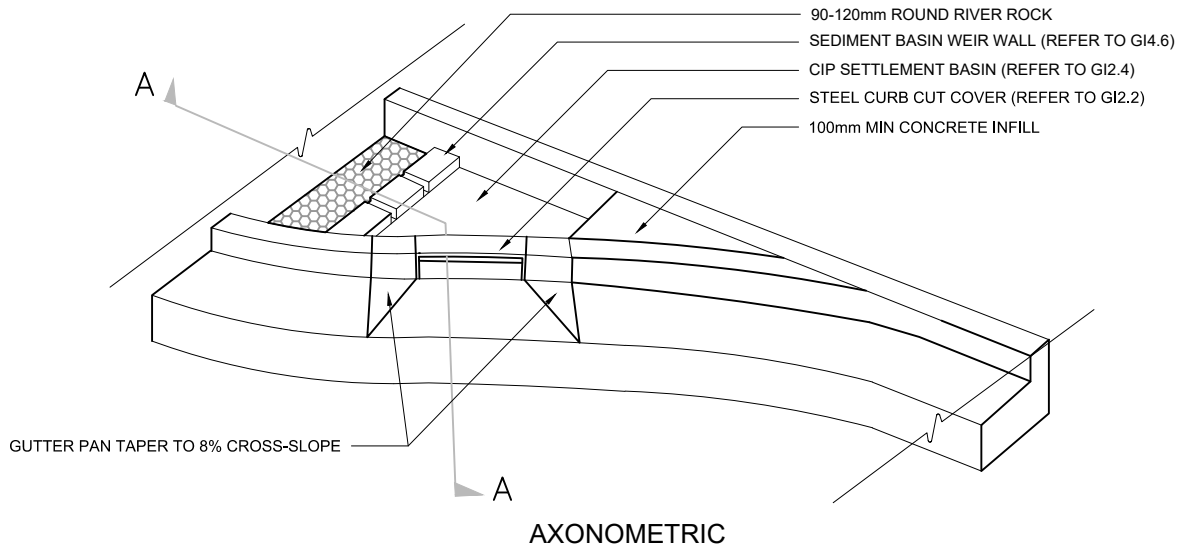

**NOTES:**

1. THIS DETAIL TO BE READ IN CONJUNCTION WITH DRAWING GI4.6.
2. INSTALL EMBEDDED REINFORCEMENT AND CONCRETE IN CONFORMANCE WITH CITY OF VANCOUVER CONSTRUCTION SPECIFICATIONS.
3. STRUCTURAL MEMBER SIZING AND ORIENTATION OF ELEMENT TO BE CONFIRMED BY THE ENGINEER. REINFORCEMENT TO BE INSTALLED AS OUTLINED IN THIS DRAWING, UNLESS OTHERWISE NOTED BY THE ENGINEER.
4. CONNECTION OF SEDIMENT BASIN TO GI BANDING IS NOT REQUIRED UNLESS NOTED BY THE ENGINEER. CONNECTION TO INLET APRON NOT REQUIRED EXCEPT FOR EXTENSION OF SEDIMENT BASIN REINFORCEMENT, AS SHOWN IN THIS DETAIL.
5. NOTIFY THE ENGINEER IF EXISTING SITE CONDITIONS DIFFER FROM THOSE SHOWN IN THIS DETAIL.

**SECTION A-A**

REV.	REVISION DATE	APPROVED

**BIORETENTION  
CURB CUT SEDIMENT BASIN**

ISSUE DATE: FEBRUARY 2026

APPROVED BY: N. MEAD-FOX

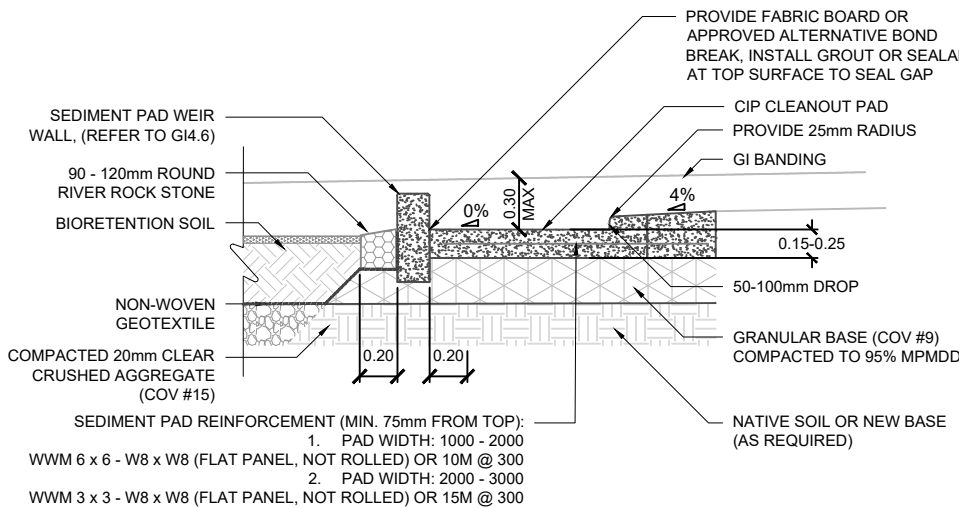
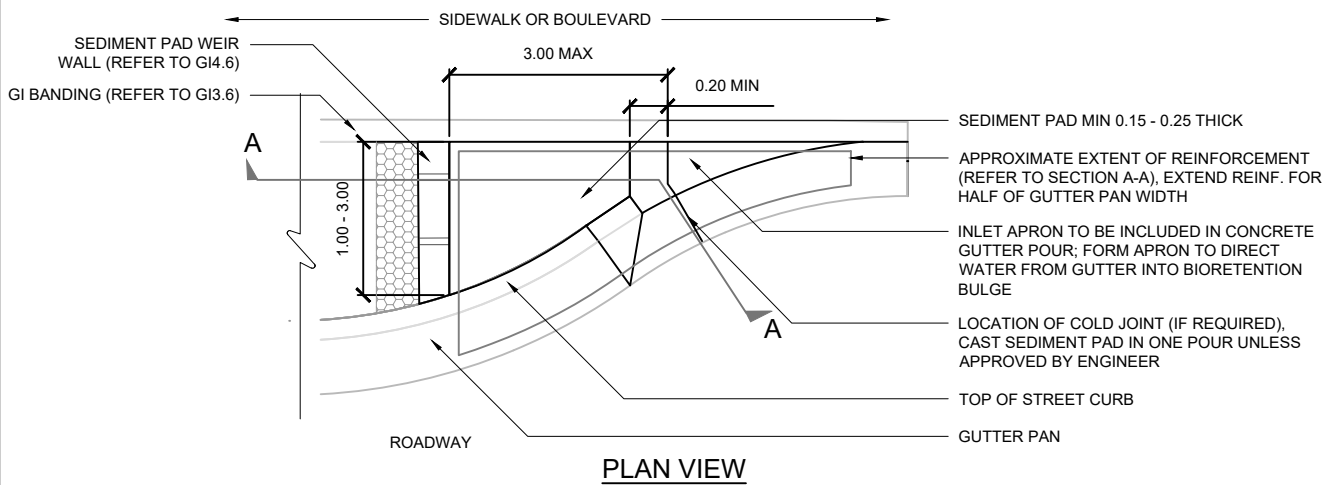
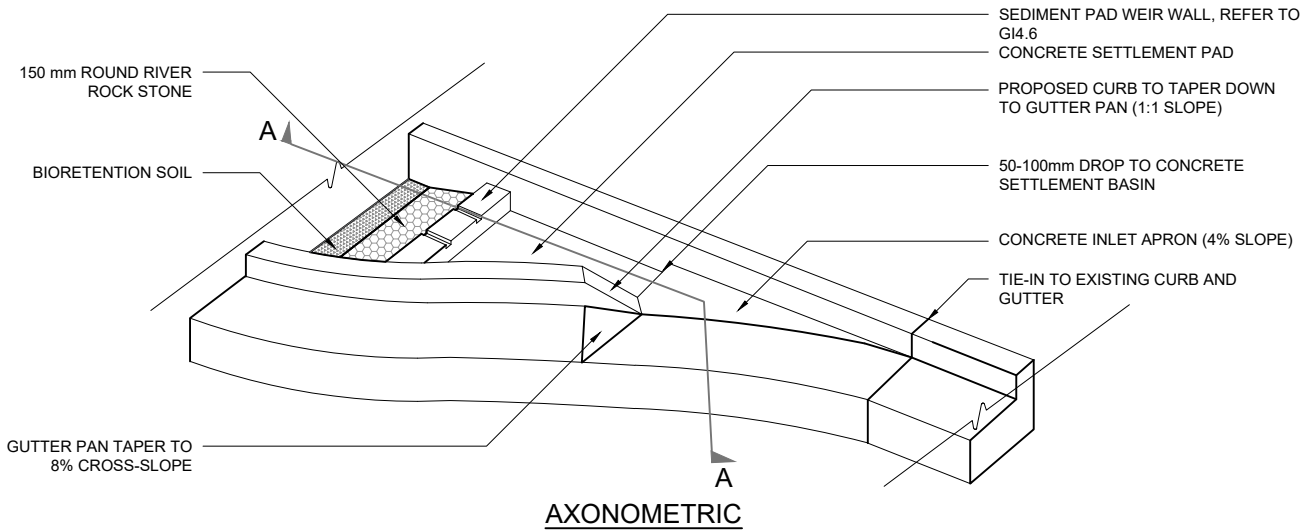

**NOTES:**

1. THIS DETAIL TO BE READ IN CONJUNCTION WITH DRAWING GI4.6.
2. REFER TO DESIGN MEMO FOR THIS STANDARD DETAIL WHICH OUTLINES DESIGN CRITERIA AND APPLIED LOADING.
3. INSTALL EMBEDDED REINFORCEMENT AND CONCRETE IN CONFORMANCE WITH CITY OF VANCOUVER CONSTRUCTION SPECIFICATIONS.
4. STRUCTURAL MEMBER SIZING AND ORIENTATION OF ELEMENT TO BE CONFIRMED BY THE ENGINEER. REINFORCEMENT TO BE INSTALLED AS OUTLINED IN THIS DRAWING, UNLESS OTHERWISE NOTED BY THE ENGINEER.
5. CONNECTION OF SEDIMENT PAD TO GI BANDING IS NOT REQUIRED UNLESS NOTED BY THE ENGINEER. CONNECTION TO INLET APRON NOT REQUIRED EXCEPT FOR EXTENSION OF SEDIMENT PAD REINFORCEMENT, AS SHOWN IN THIS DETAIL.
6. NOTIFY THE ENGINEER IF EXISTING SITE CONDITIONS DIFFER FROM THOSE SHOWN IN THIS DETAIL.

REV.	REVISION DATE	APPROVED

**BIORETENTION  
STRAIGHTAWAY SEDIMENT PAD**

ISSUE DATE: FEBRUARY 2026  
 APPROVED BY: N. MEAD-FOX

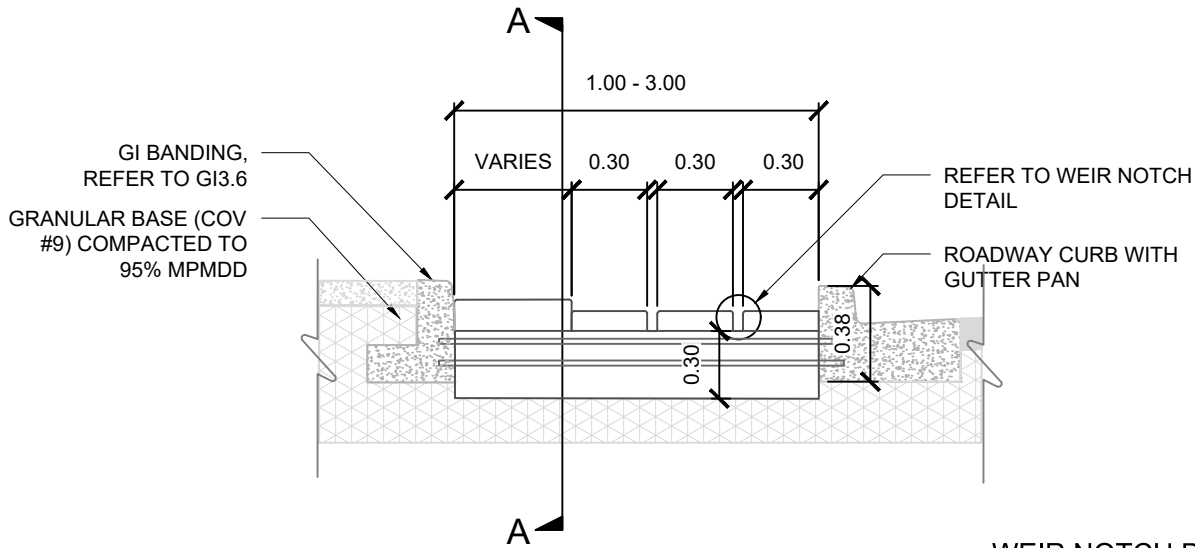

**FRONT VIEW  
(CONCRETE LAYOUT)**

**WEIR NOTCH DETAIL**

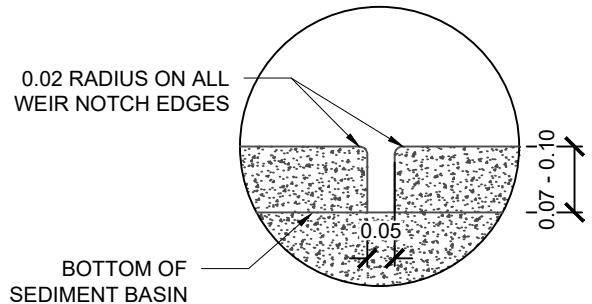

RADIUS = 0.03  
15M @ 300 O.C. E/W  
PROVIDE MIN. 2 DOWELS,  
EMBED MIN 150mm INTO  
EXISTING CURB OR  
BANDING, TYP. AT BOTH  
SIDES

90 - 120mm ROUND RIVER  
ROCK STONE

NON-WOVEN GEOTEXTILE  
20mm CLEAR  
CRUSHED AGGREGATE  
(COV #15)

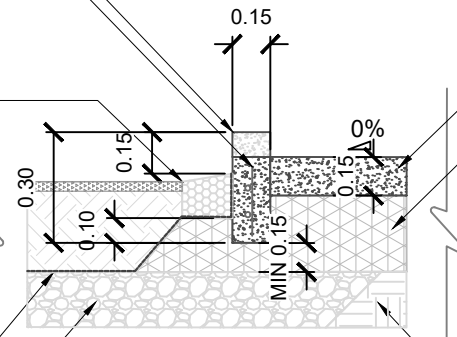

**SECTION A-A**

STRAIGHTAWAY SEDIMENT  
BASIN (REFER TO GI4.5)  
GRANULAR BASE (COV #9)  
COMPACTED TO 95%  
MPMDD

NATIVE SOIL OR NEW BASE  
(AS REQUIRED)

**NOTES:**

1. THIS DETAIL TO BE READ IN CONJUNCTION WITH DRAWING GI4.4 AND GI4.5
2. WEIR WALL TO BE CONNECTED TO THE ADJACENT BANDING AND CURB USING EMBEDDED DOWELS CONNECTED TO THE WEIR WALLS MAIN REINFORCEMENT
3. INSTALL EMBEDDED REINFORCEMENT AND CONCRETE IN CONFORMANCE WITH CITY OF VANCOUVER CONSTRUCTION SPECIFICATIONS.
4. STRUCTURAL MEMBER SIZING AND ORIENTATION OF ELEMENT TO BE CONFIRMED BY THE ENGINEER. REINFORCEMENT TO BE INSTALLED AS OUTLINED IN THIS DRAWING, UNLESS OTHERWISE NOTED BY THE ENGINEER.
5. NOTIFY THE ENGINEER IF EXISTING SITE CONDITIONS DIFFER FROM THOSE SHOWN IN THIS DETAIL.

REV.	REVISION DATE	APPROVED

**BIORETENTION  
SEDIMENT BASIN WEIR WALL**

ISSUE DATE: FEBRUARY 2026

APPROVED BY: N. MEAD-FOX

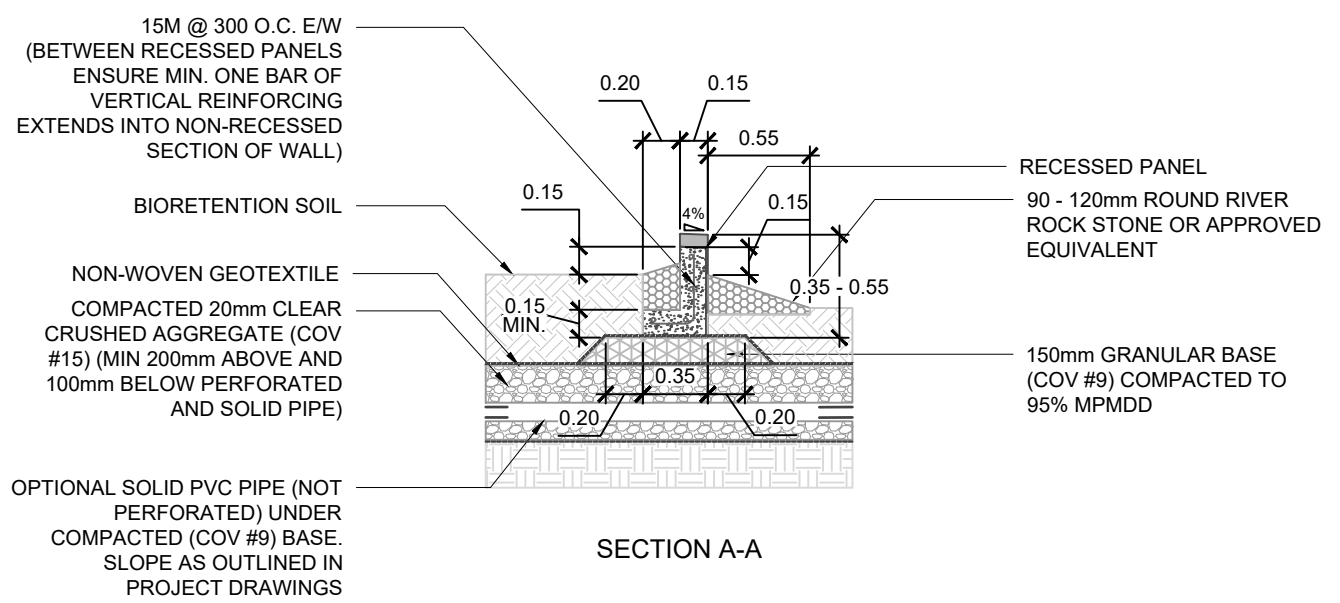
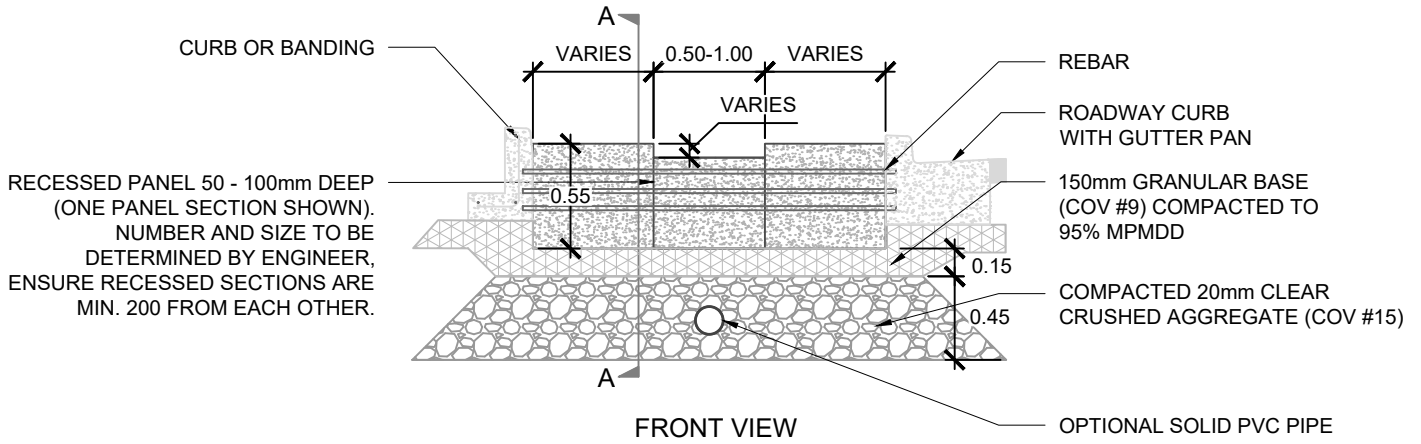

- NOTES:**
- HAND-TAMP 20mm CLEAR CRUSHED AGGREGATE AND GRANULAR BASE WITHIN 300mm OF PERFORATED PIPE TO AVOID DAMAGE.
  - INSTALL EMBEDDED REINFORCEMENT AND CONCRETE IN CONFORMANCE WITH CITY OF VANCOUVER CONSTRUCTION SPECIFICATIONS.
  - STRUCTURAL MEMBER SIZING AND ORIENTATION OF ELEMENT TO BE CONFIRMED BY THE ENGINEER. REINFORCEMENT TO BE INSTALLED AS OUTLINED IN THIS DRAWING, UNLESS OTHERWISE NOTED BY THE ENGINEER.
  - NOTIFY THE ENGINEER IF EXISTING SITE CONDITIONS DIFFER FROM THOSE SHOWN IN THIS DETAIL.

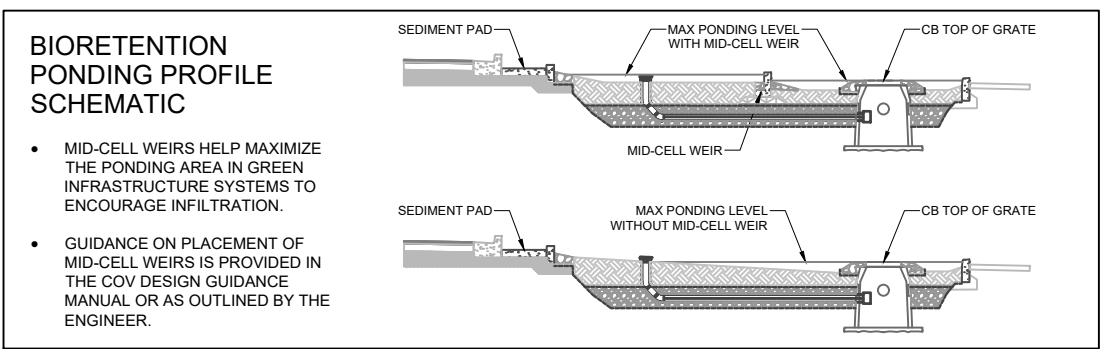

- BIORETENTION PONDING PROFILE SCHEMATIC**
- MID-CELL WEIRS HELP MAXIMIZE THE PONDING AREA IN GREEN INFRASTRUCTURE SYSTEMS TO ENCOURAGE INFILTRATION.
  - GUIDANCE ON PLACEMENT OF MID-CELL WEIRS IS PROVIDED IN THE COV DESIGN GUIDANCE MANUAL OR AS OUTLINED BY THE ENGINEER.

REV.	REVISION DATE	APPROVED

**BIORETENTION CONCRETE CHECK DAM**

ISSUE DATE: FEBRUARY 2026  
APPROVED BY: N. MEAD-FOX