

GI GENERAL COMPONENTS DESIGN NOTES AND GUIDANCE

PURPOSE:

THE FOLLOWING COMPONENTS MAY BE USED IN A VARIETY OF GI SYSTEMS. THESE COMPONENTS SHOW PHYSICAL INFRASTRUCTURE COMPONENTS THAT MAY HAVE FIXED OR VARIED DIMENSIONS.

DESIGNER NOTES & GUIDELINES:

1. ALL DIMENSIONS ARE IN METERS UNLESS OTHERWISE NOTED.
2. THE DESIGNER MUST ADAPT COMPONENT DIMENSIONS TO ADDRESS SITE-SPECIFIC CONDITIONS. DETAILS REQUIRING CUSTOM DIMENSIONS SHOULD BE SHOWN ON CONSTRUCTION DRAWINGS. UNADJUSTED COMPONENTS MAY BE REFERENCED.
3. THE COMPONENTS REQUIRED AND RECOMMENDED FOR SPECIFIC GI SYSTEMS ARE REFERENCED ON THE SYSTEM TEMPLATES SHOWN IN GI STANDARD DRAWING SECTION 4, SECTION 5, AND SECTION 6.
4. THE DESIGNER MUST EVALUATE UTILITY SURVEYS FOR POTENTIAL UTILITY CROSSINGS OR CONFLICTS.
5. MINIMUM UTILITY SETBACKS AND PROTECTION MEASURES MUST CONFORM TO CURRENT CITY OF VANCOUVER ASSET PROTECTION STANDARDS AND OTHER UTILITY PROVIDER REQUIREMENTS.
6. BIORETENTION VEGETATION MUST BE SPECIFIED BY DESIGN PROFESSIONAL PER CoV GREEN INFRASTRUCTURE VEGETATION GUIDANCE

LAYOUT REQUIREMENTS:

1. REFER TO THE CITY OF VANCOUVER ACCESSIBILITY STRATEGY, STANDARD DRAWINGS AND CONSTRUCTION SPECIFICATIONS FOR RIGHT-OF-WAY, PARKING SPACE, AND ACCESSIBLE PATH REQUIREMENTS.
2. LOCATE CURB CUTS AND GUTTER MODIFICATIONS TO AVOID CONFLICTS WITH ACCESSIBILITY REQUIREMENTS (E.G., LOCATE OUTSIDE OF CROSSWALKS).
3. REFER TO THE DESIGN MANUAL FOR GUIDANCE ON PLACING CONCRETE CHECK DAMS

DESIGNER CHECKLIST (MUST SPECIFY, AS APPLICABLE):

- CONFIRM UTILITY PROTECTION MEASURES WITH GII STAFF
- CONFIRM MONITORING REQUIREMENTS WITH GII STAFF
- SELECT CURB EDGES AND BANDING ACCORDING TO GII STAFF INSTRUCTION
- CONFIRM PERFORATED PIPE LAYOUT AND PERFORATION REQUIREMENTS WITH GII STAFF
- CONFIRM ACCEPTABILITY OF ALL CATCHBASINS AND INSPECTION CHAMBERS WITH SEWER DEPARTMENT

GENERAL COMPONENT DRAWING DESCRIPTIONS

| | | |
|------|-----------------------------------|--|
| 3.1. | PRECAST CONCRETE CATCHBASIN | PRECAST OFFSET CBS ARE A SHORTENED CATCHBASIN WITH A SMALL SUMP. PRECAST CBS SHOULD BE USED WHEN SDD S11.9 IS INFEASIBLE DUE TO PROJECT CONSTRAINTS. OFFSET CBS ARE TO BE USED WHEN DRAINAGE IS BEING DIRECTED TO ANOTHER FEATURE THAT CAN REPLICATE THE FUNCTION OF THE SUMP SUCH AS AN INSPECTION CHAMBER. |
| 3.2. | MONITORING WELL | MONITORING WELLS ARE USED TO MEASURE THE SATURATION LEVEL OF SOIL IN A GREEN INFRASTRUCTURE SYSTEM. SATURATION LEVEL IS A GOOD INDICATOR OF HOW WELL A GREEN INFRASTRUCTURE SYSTEM IS DRAINING. THIS DRAWING PROVIDES MULTIPLE MONITORING WELLS FOR DIFFERENT SURFACE TREATMENTS. |
| 3.3. | INSPECTION CHAMBER | INSPECTION CHAMBERS ARE USED TO MONITOR DRAINAGE IN LARGER GREEN INFRASTRUCTURE SYSTEMS. THEY CONNECT UNDERDRAINS SUCH AS THOSE IN GI3.7. TO CATCHBASINS AND SEWER LEADS. |
| 3.4. | GI CLEANOUT | CLEANOUTS ARE INSTALLED AT THE "UPSTREAM" END OF PERFORATED PIPES. THEY ARE INSTALLED TO MAKE IT EASIER TO FLUSH UNDERDRAINS AND CLEAR PERFORATIONS. |
| 3.5. | TREE TRENCH CURB EDGES | THESE CURB EDGES ARE DESIGNED TO CONFINE OPEN TREE PIT AREAS. THEY ARE TO BE PLACED PERPENDICULAR TO STREET CURBS AND SIDEWALKS. |
| 3.6. | GI BANDING | GI BANDING IS DESIGNED TO CONFINE GREEN INFRASTRUCTURE ASSETS AND CONTAIN PONDED WATER. BANDING IS USED ALONG THE EDGES OF A GREEN INFRASTRUCTURE SYSTEM THAT ARE NOT ADJACENT TO A ROADWAY. PREFERRED BANDING OPTIONS DEPEND ON THE DEPTH OF PONDING AND THE ADJACENT SURFACE TREATMENT. |
| 3.7. | UNDERDRAIN AND DISTRIBUTION PIPES | PERFORATED PIPES MAY BE USED AS UNDERDRAINS TO SLOWLY REMOVE WATER FROM A GREEN INFRASTRUCTURE ASSET, OR AS DISTRIBUTION PIPES, WHICH CAN CONVEY WATER INTO A GREEN INFRASTRUCTURE ASSET. PERFORATED PIPE DESIGN DEPENDS ON THE DESIRED RATE OF FLOW THROUGH THE PIPE AND THE EXPECTED INFILTRATION RATE OF THE SYSTEM. |
| 3.8. | PVC CATCHBASIN | A PVC CATCHBASIN IS USED TO CAPTURE OVERFLOW FROM A GI SYSTEM AN DIRECT IT INTO THE SEWER SYSTEM. PVC CATCHBASINS MAY ONLY BE USED WHEN SURROUNDED BY GROWING MEDIUM. THEY ARE A MORE AFFORDABLE ALTERNATIVE TO TRADITIONAL CATCHBASINS AND THE OVERLYING DOMED INLET GRATE HELPS PREVENT CLOGGING FROM SEDIMENT AND DEBRIS. |

| | | |
|------|---------------|----------|
| REV. | REVISION DATE | APPROVED |
| | | |
| | | |

**GENERAL COMPONENTS
GI COMPONENTS DESIGN GUIDANCE**

ISSUE DATE: FEBRUARY 2026
APPROVED BY: N. MEAD-FOX

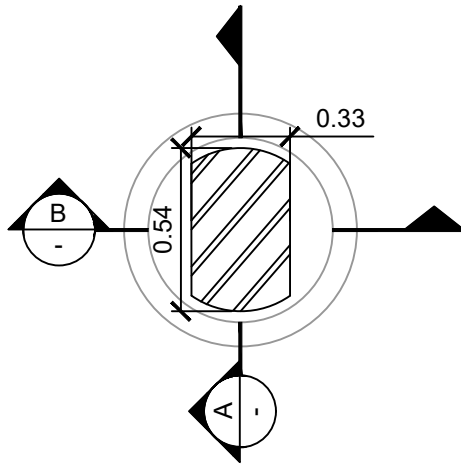

PLAN VIEW

TR 23/24 'CURB STYLE'
FRAME & GRATE
SET ON 'CURB STYLE'
CONCRETE
LID, REINFORCED TO MEET
HS-20 LIVE LOADING

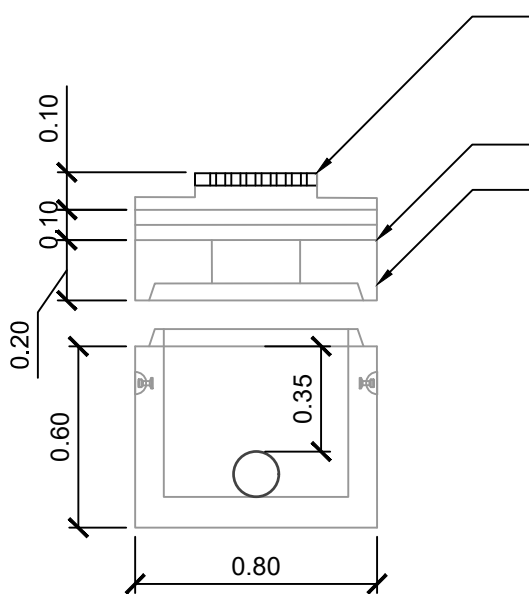

SECTION B

COV GRATE No. 31 & FRAME
No. 30. CEMENT FRAME IN
PLACE AFTER ALIGNING

50mm RISERS. MIN 1, MAX 3

CATCHBASIN LID

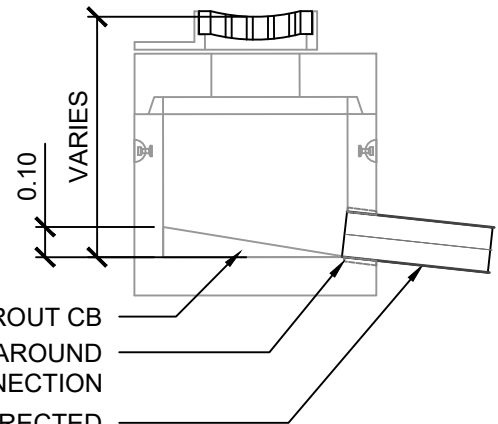

SECTION A

GROUT CB
GROUT SEALING AROUND
PIPE CONNECTION
CB LEAD MIN 1% DIRECTED
TO MANHOLE, CATCHBASIN,
OR STORM SEWER

NOTES:

1. WHEN SUMP IS INSTALLED ROADSIDE TO CATCHBASIN, CONNECTION PIPE FROM CB TO SUMP SHALL BE DUCTILE IRON OR CONCRETE ENCASED.
2. USE 750mm BARREL AT ALL SAG POINTS.
3. EXPANSION JOINT REQUIRED IN CURB AND GUTTER AT MIDDLE OF CB FRAME FOR 600mm BARREL INSTALLATIONS OR 1m EACH SIDE OF FRAME FOR 750mm BARREL INSTALLATIONS.
4. GROUT TO SEAL PIPE OPENING, LIFTING HOLES, TEMPORARY DRAIN HOLE(S), SECTIONS, AND SPACER RINGS, INSIDE AND OUT.

| REV. | REVISION DATE | APPROVED |
|------|---------------|----------|
| | | |
| | | |
| | | |

GENERAL COMPONENTS
GI OFFSET CATCHBASIN

ISSUE DATE: FEBRUARY 2026

APPROVED BY: N. MEAD-FOX

3.2A: MONITORING WELL WITH CLEAR CRUSHED AGGREGATE UNDER PERMEABLE PAVEMENT

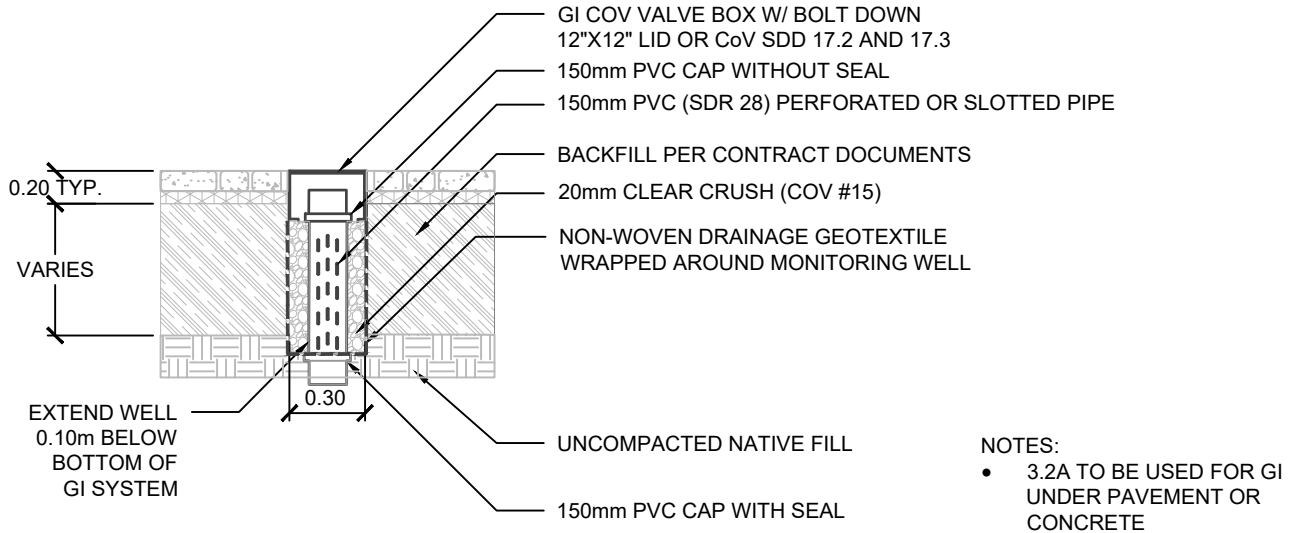

3.2B: MONITORING WELL WITH PERFORATED DRAINAGE BOARD UNDER PAVEMENT

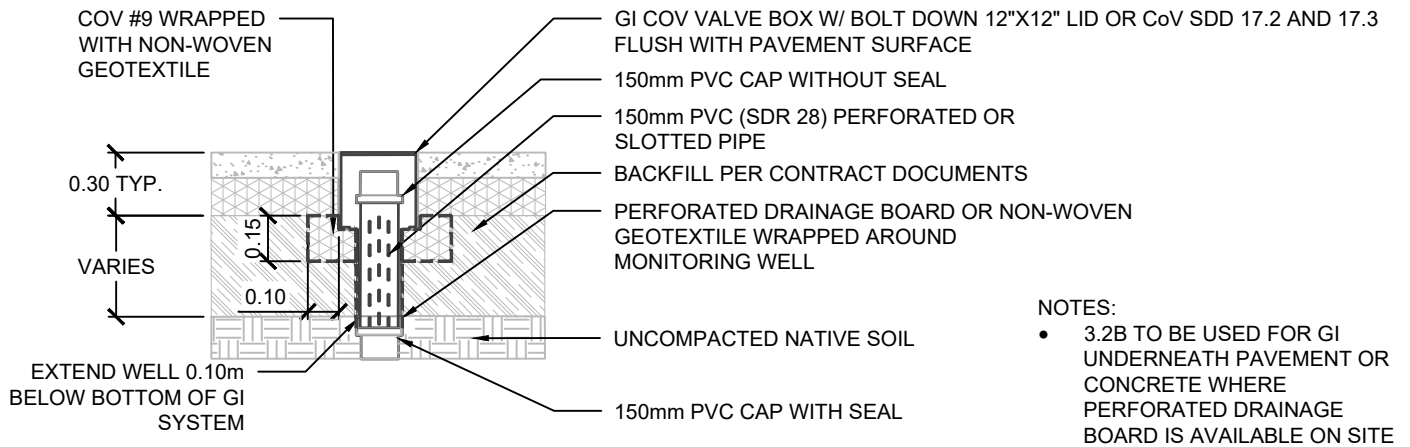

3.2C: MONITORING WELL IN SOIL

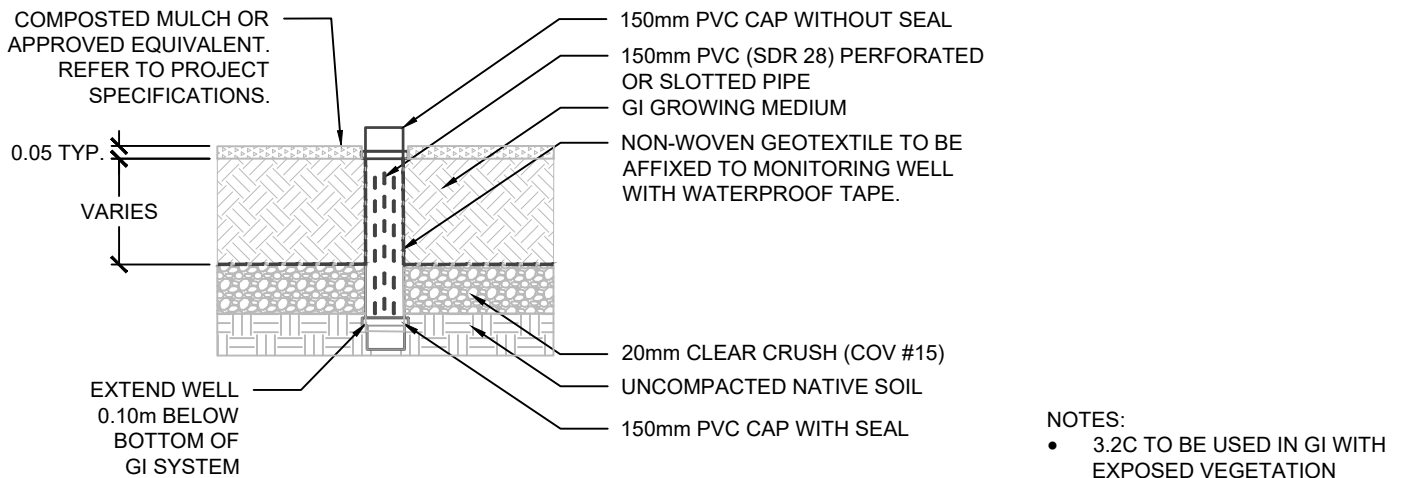

| REV. | REVISION DATE | APPROVED |
|------|---------------|----------|
| | | |
| | | |
| | | |

**GENERAL COMPONENTS
MONITORING WELL**

ISSUE DATE: FEBRUARY 2026

APPROVED BY: N. MEAD-FOX

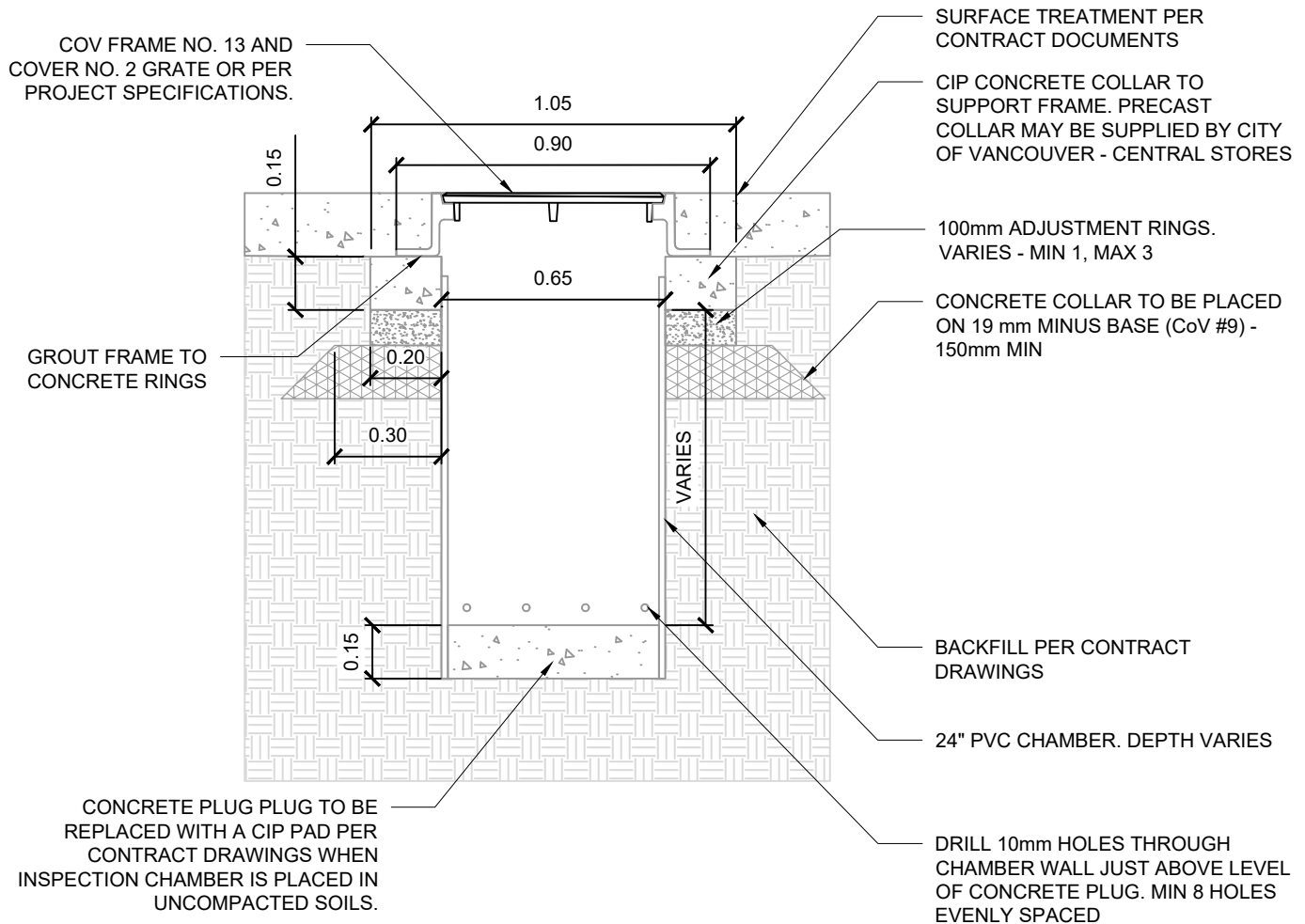

NOTES:

1. GI INSPECTION CHAMBERS IN THE ROADWAY OR IN PAVED BOULEVARDS MUST BE DESIGNED FOR H20 LOADING PLUS 25%.
2. A 6.0m VERTICAL CLEARANCE IS PREFERRED OVER ALL INSPECTION CHAMBERS.
3. GI INSPECTION CHAMBERS SHOULD BE PLACED AT THE LOW POINT OF THE CONNECTED GI SYSTEM.
4. INSPECTION CHAMBERS CONNECTED BY DISTRIBUTION PIPES SHOULD HAVE A MAXIMUM SEPARATION DISTANCE OF 40 METERS

| REV. | REVISION DATE | APPROVED |
|------|---------------|----------|
| | | |
| | | |
| | | |

GENERAL COMPONENTS
INSPECTION CHAMBER

ISSUE DATE: FEBRUARY 2026
APPROVED BY: N. MEAD-FOX

3.4A CLEANOUT IN PAVEMENT

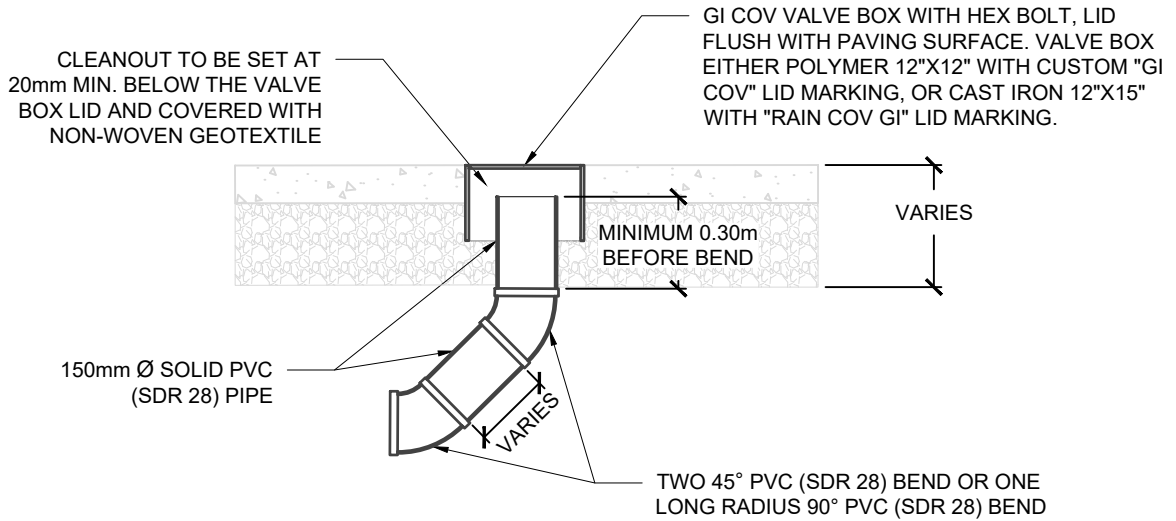

3.4B CLEANOUT IN SOIL

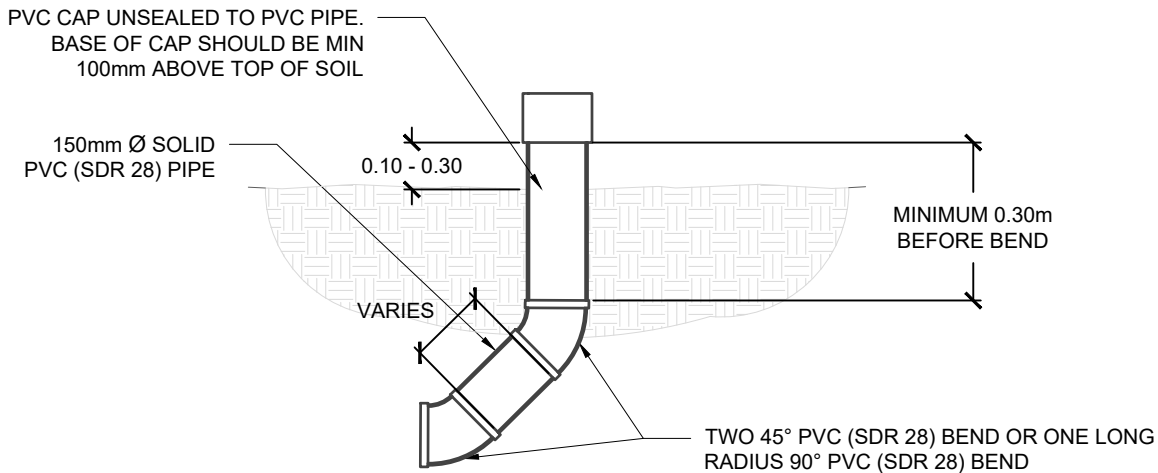

NOTES:

1. GI CLEANOUTS IN THE ROADWAY OR IN PAVED BOULEVARDS (GI3.4A) MUST BE DESIGNED FOR H₂O LOADING PLUS 25%. REFER TO S17.2 FOR VALVE BOX STRUCTURAL DETAILS
2. GI CLEANOUTS IN SOIL AREAS (GI3.4B) SHOULD MAY BE TOPPED WITH A PVC CAP OR A DOME GRATE. BOTH MUST NOT BE SEALED TO THE CONNECTED PVC PIPE TO ALLOW FOR FUTURE REMOVAL AND MAINTENANCE.
3. GI CLEANOUTS SHOULD BE PLACED AT THE HIGH POINT OF THE CONNECTED GI SYSTEM.
4. PIPES CONNECTING CLEANOUTS TO INSPECTION CHAMBERS OR CATCH BASINS SHOULD HAVE A MAXIMUM SEPARATION DISTANCE OF 40 METERS.

| REV. | REVISION DATE | APPROVED |
|------|---------------|----------|
| | | |
| | | |
| | | |

GENERAL COMPONENTS
GI CLEANOUT

ISSUE DATE: FEBRUARY 2026
APPROVED BY: N. MEAD-FOX

3.5A. L-SHAPE UNDER PAVERS

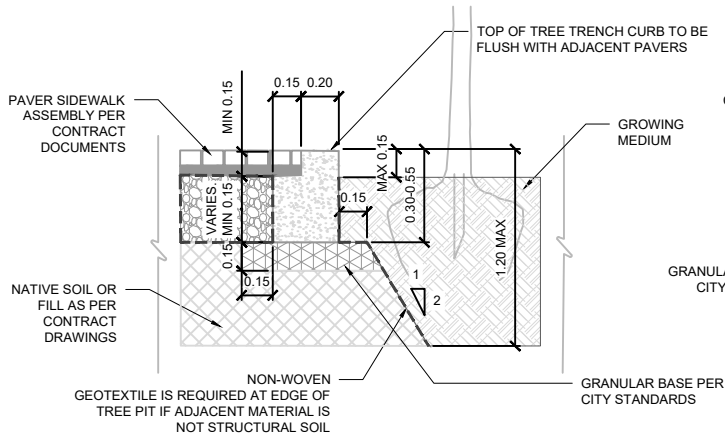

3.5B. L-SHAPE UNDER CIP SIDEWALK

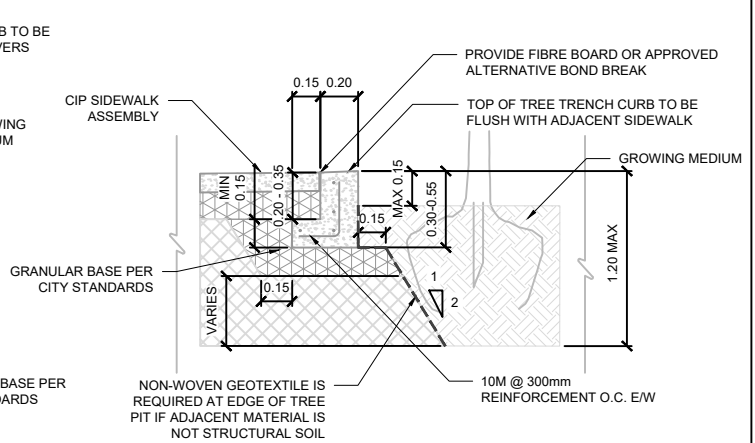

3.5C. THICKENED CONCRETE EDGE

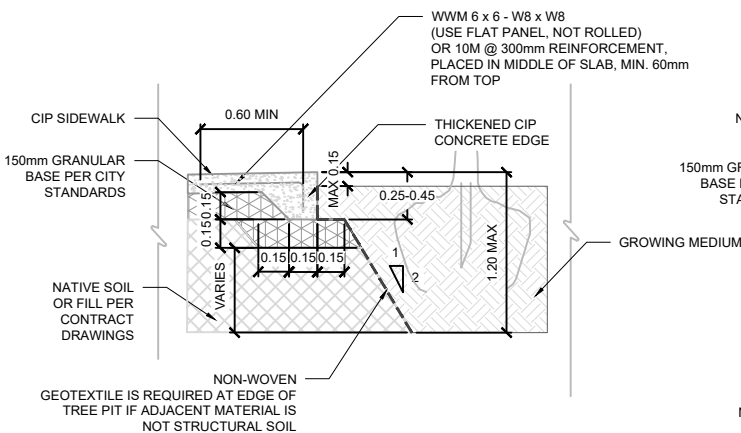

3.5D. RECTANGULAR BANDING

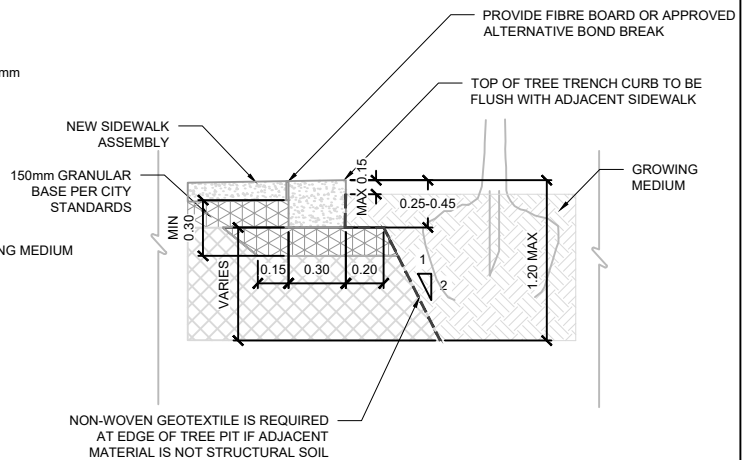

SOIL EXCAVATION, COMPACTION AND BACKFILLING

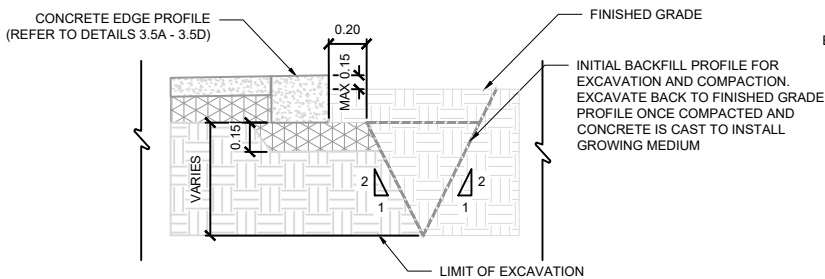

CONTEXTUAL PLAN VIEW

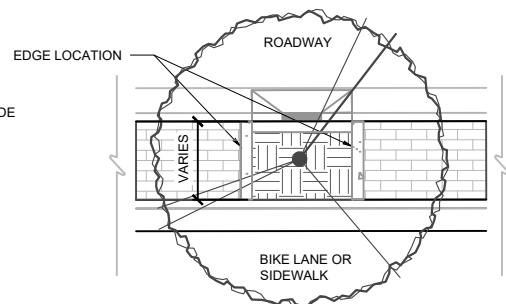

NOTES:

1. GROWING MEDIUM THAT IS NOT ADJACENT TO STRUCTURAL SOIL MUST BE WRAPPED WITH NON-WOVEN GEOTEXTILE ON ALL SIDES
2. TYPE A TO BE USED IF ADJACENT SIDEWALK IS BEING CONSTRUCTED WITH PERMEABLE PAVERS. GROWING MEDIUM MAY BE UP TO 550mm BELOW TOP OF THE ADJACENT SIDEWALK.
3. TYPE B TO BE USED IF ADJACENT SIDEWALK IS A STANDARD CIP SIDEWALK.
4. TYPE C TO BE USED IF ADJACENT SIDEWALK IS BEING CONSTRUCTED AND GROWING MEDIUM IS WITHIN 50mm OF THE TOP OF THE ADJACENT SIDEWALK (NO PONDING DEPTH IS REQUIRED).
5. TYPE D TO BE USED WITH EXISTING SIDEWALK AND GROWING MEDIUM IS WITHIN 50mm OF THE TOP OF THE BANDING (NO PONDING DEPTH IS REQUIRED).
6. DESIGN CRITERIA, APPLIED LOADING CONSTRAINTS, AND MAXIMUM VERTICAL POINT LOADING FOR VARIOUS COVER WIDTHS MAY BE PROVIDED UPON REQUEST.
7. INSTALL EMBEDDED REINFORCEMENT AND CONCRETE IN CONFORMANCE WITH CITY OF VANCOUVER CONSTRUCTION SPECIFICATIONS.
8. STRUCTURAL MEMBER SIZING AND ORIENTATION OF ELEMENT TO BE CONFIRMED BY THE PROJECT ENGINEER. REINFORCEMENT TO BE INSTALLED AS OUTLINED IN THIS DRAWING, UNLESS OTHERWISE NOTED BY THE ENGINEER.
9. NOTIFY THE ENGINEER IF EXISTING SITE CONDITIONS DIFFER FROM THOSE SHOWN IN THIS DETAIL.
10. REINFORCEMENT IS NOT REQUIRED FOR 3.5B IF VERTICAL PORTION OF BANDING WALL IS LESS THAN 200mm ABOVE TOE

| REV. | REVISION DATE | APPROVED |
|------|---------------|----------|
| | | |
| | | |

GENERAL COMPONENTS
TREE TRENCH CURB EDGES

ISSUE DATE: FEBRUARY 2026
APPROVED BY: N. MEAD-FOX

3.6A: PREFERRED

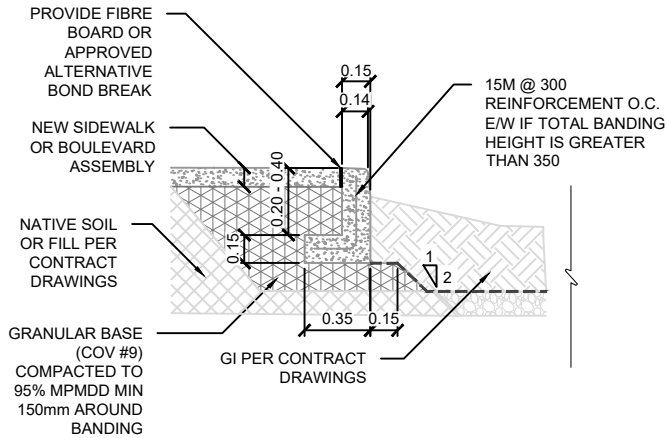

PROVIDE FIBRE BOARD OR APPROVED ALTERNATIVE BOND BREAK

3.6B: ALTERNATE

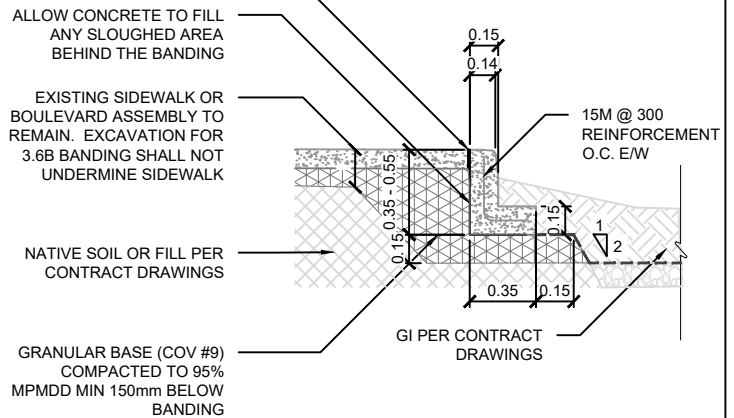

SOIL EXCAVATION, COMPACTION AND BACKFILLING

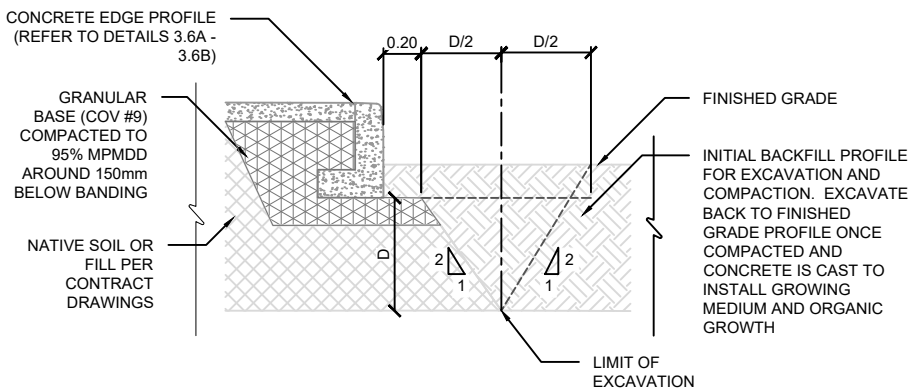

PLAN VIEW FOR CONTEXT

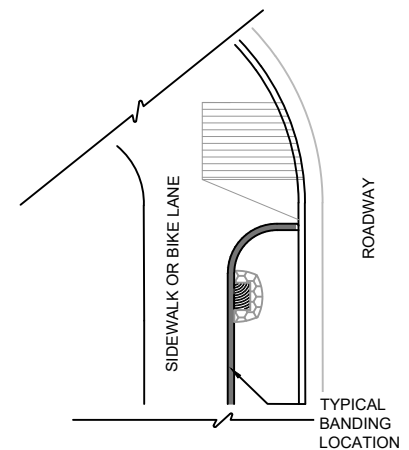

NOTES:

1. GI BANDING SHALL NOT BE USED AS A CURB OR IMMEDIATELY ADJACENT TO A ROADWAY.
2. TYPE A TO BE USED IF ADJACENT SIDEWALK, BIKE LANE, OR BOULEVARD IS BEING RECONSTRUCTED.
3. TYPE B TO BE USED IF ADJACENT SIDEWALK, BIKE LANE, OR BOULEVARD WILL REMAIN.
4. DESIGN CRITERIA, APPLIED LOADING CONSTRAINTS, AND MAXIMUM VERTICAL POINT LOADING FOR VARIOUS COVER WIDTHS MAY BE PROVIDED UPON REQUEST.
5. IF THE ADJACENT SURFACE IS NOT A SIDEWALK (I.E. A RETAINED BOULEVARD) TYPE A AND TYPE B CURBS MAY BE RAISED UP TO 150mm ABOVE THE ADJACENT SURFACE ELEVATION IF REQUIRED BY GRADING CONDITIONS.
6. THE MAXIMUM BANDING HEIGHT SHALL BE 550mm.
7. INSTALL EMBEDDED REINFORCEMENT AND CONCRETE IN CONFORMANCE WITH CITY OF VANCOUVER CONSTRUCTION SPECIFICATIONS.
8. STRUCTURAL MEMBER SIZING AND ORIENTATION OF ELEMENT TO BE CONFIRMED BY THE ENGINEER. REINFORCEMENT TO BE INSTALLED AS OUTLINED IN THIS DRAWING, UNLESS OTHERWISE NOTED BY THE ENGINEER.
9. NOTIFY THE ENGINEER IF EXISTING SITE CONDITIONS DIFFER FROM THOSE SHOWN IN THIS DETAIL.
10. REINFORCEMENT IS NOT REQUIRED IF THE TOTAL HEIGHT OF THE BANDING WALL IS LESS THAN 350mm (NOTE REINFORCEMENT WILL ALWAYS BE REQUIRED WHEN THE TOP OF BANDING GRADE IS ABOVE THE ADJACENT PAVED SURFACE).

| REV. | REVISION DATE | APPROVED |
|------|---------------|----------|
| | | |
| | | |
| | | |

GENERAL COMPONENTS
GI BANDING

ISSUE DATE: FEBRUARY 2026
APPROVED BY: N. MEAD-FOX

3.7A NON-INFILTRATION
GI UNDERDRAIN

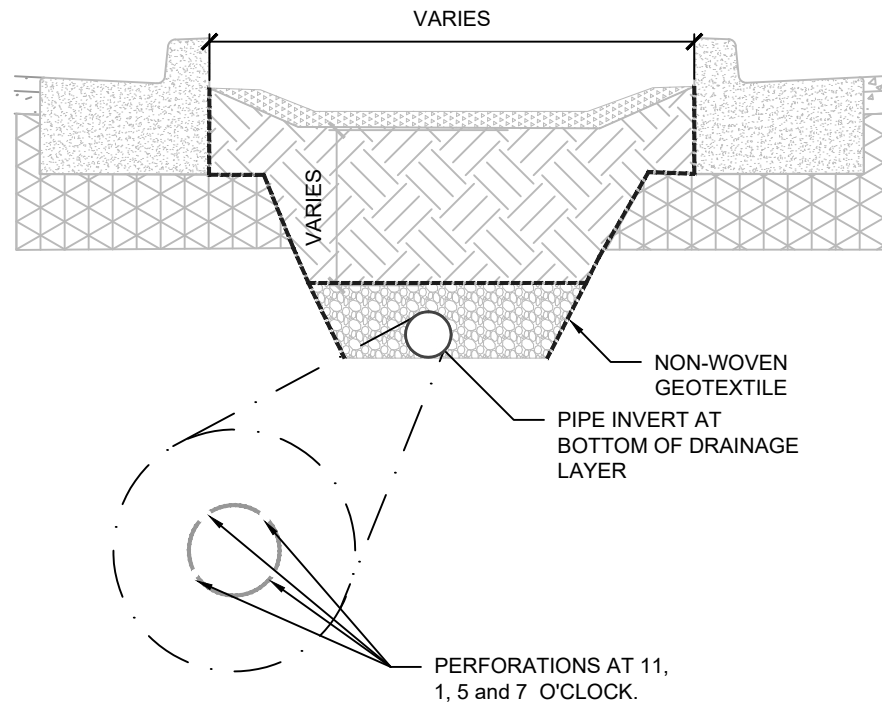

3.7B PARTIALLY INFILTRATING
GI UNDERDRAIN

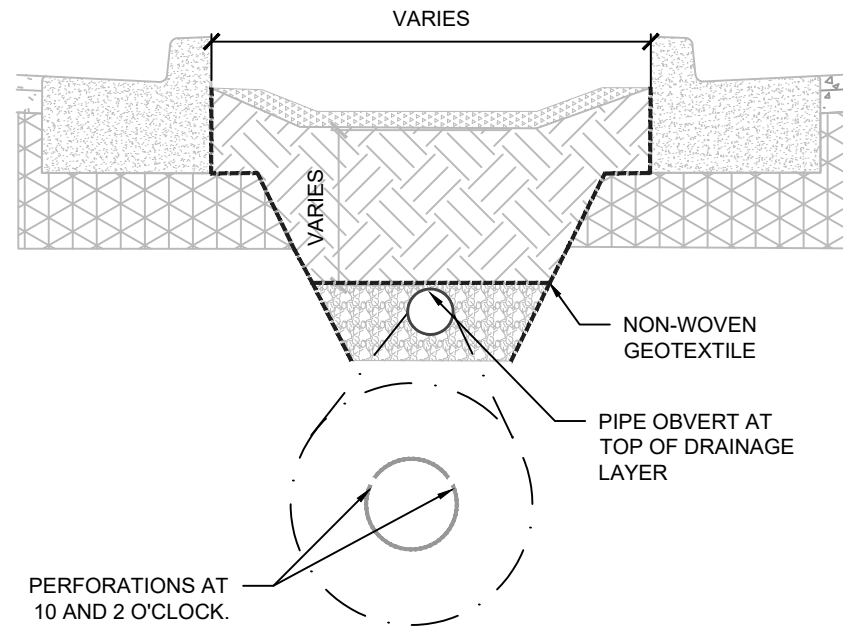

3.7C FLAT (PREFERRED) OR SLOPED
DISTRIBUTION PIPE

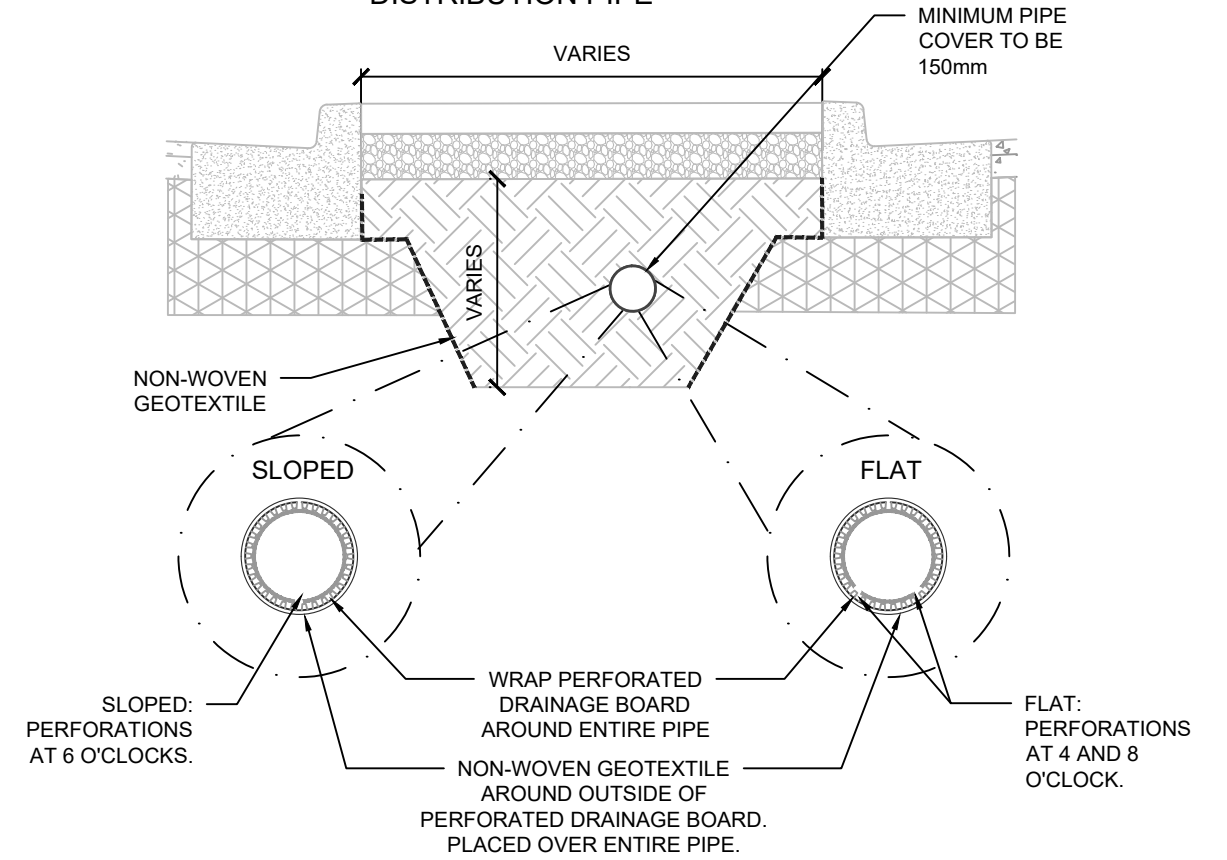

3.7D FLAT DISTRIBUTION PIPE IN
BIORETENTION SOIL

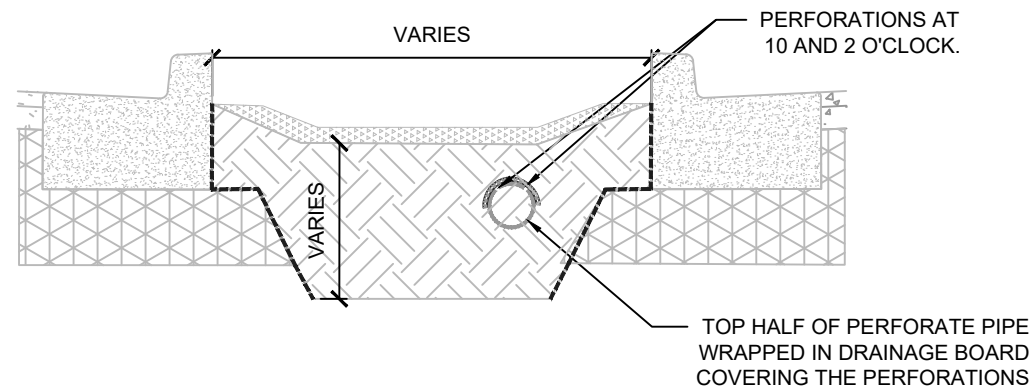

3.7E FLAT DISTRIBUTION PIPE IN
ENGINEERED SOIL

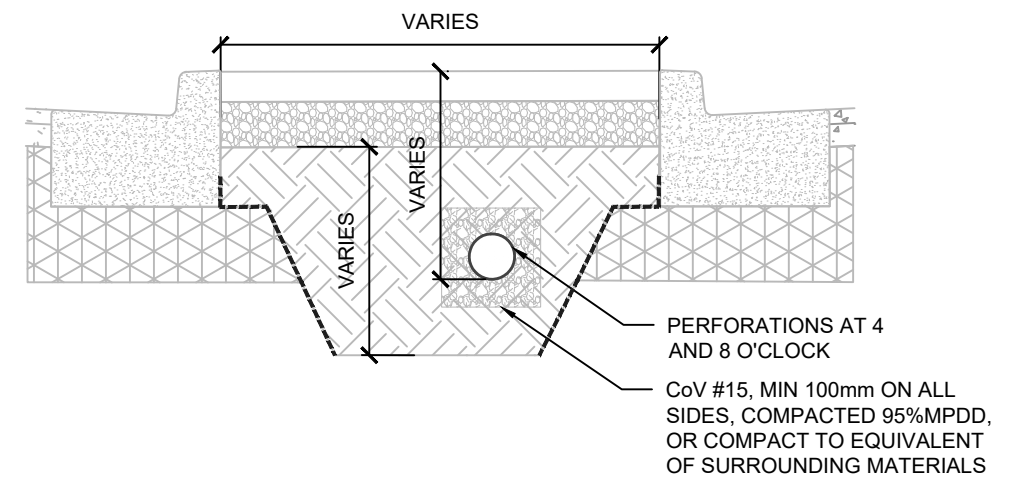

NOTE: SLOPED DISTRIBUTION PIPES MAY ONLY BE USED ON PIPE RUNS GREATER THAN 10.0m. MAX SLOPE OF 5%..

NOTES:

- 3.7A TO BE USED IF GI ASSET IS NON-INFILTRATING (i.e. FILTRATION ONLY). TYPICALLY USED IN BIORETENTION SYSTEMS.
- 3.7B TO BE USED IF GI ASSET CAN INFILTRATE BUT REQUIRES AN UNDERDRAIN FOR SOIL DRAINAGE. TYPICALLY USED IN BIORETENTION SYSTEMS.
- IF THE PERFORATED PIPE IS TO BE USED AS AN UNDERDRAIN TO CONVEY WATER OUT OF THE GI SYSTEM, THE INVERT OF THE PIPE SHOULD BE PLACED ABOVE THE INVERT OF THE SEWER CONNECTION.
- 3.7C, 3.7D, AND 3.7E TO BE USED TO DISTRIBUTE RAINWATER IN INFILTRATION TRENCHES AND RAINWATER TREE TRENCHES.
- IF THE PERFORATED PIPE IS TO BE USED AS A DISTRIBUTION PIPE TO CONVEY WATER INTO THE GI SYSTEM, THE INVERT SHOULD BE PLACED BELOW THE INVERT OF THE SEWER CONNECTION.
- SLOPED DISTRIBUTION PIPES MAY ONLY BE USED ON PIPE RUNS GREATER THAN 10.0m. MAX SLOPE OF 5%..
- ALL DISTRIBUTION PIPES TO BE LAID AT 0%
- UNDERDRAIN PIPES MAY BE LAID ON A SLOPE THAT MATCHES THE UNDERLYING SUB-BASE AS SHOWN IN 3.7C
- REFER TO DESIGN MANUAL FOR FURTHER DETAILS REGARDING PERFORATED PIPE DESIGN AND PLACEMENT

GENERAL COMPONENTS
UNDERDRAINS AND DISTRIBUTION PIPES

ISSUE DATE: FEBRUARY 2024
APPROVED BY: N. MEAD-FOX

| | | |
|------|---------------|---------------|
| 1 | 05/15/2025 | NICK MEAD-FOX |
| REV. | REVISION DATE | APPROVED |

PLAN VIEW

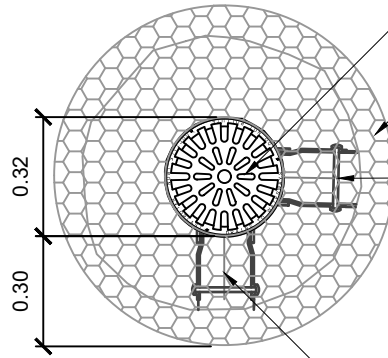

DRAIN BASIN WITH DOME GRATE OR APPROVED EQUIVALENT

90-120mm ROUND RIVER ROCK STONE OR WOOD DEBRIS FILLED COMPOST SOCK

INSERT-A-TEE OR APPROVED EQUIVALENT CONNECTED TO GI PERFORATED PIPE. ANGLE BETWEEN SEWER CONNECTION PIPE AND PERFORATED PIPE VARIES PER CONTRACT DRAWINGS.

150mm PVC SOLID PIPE TO EXISTING CB. REFER TO SEWER STANDARDS FOR MORE INFORMATION.

SECTION VIEW

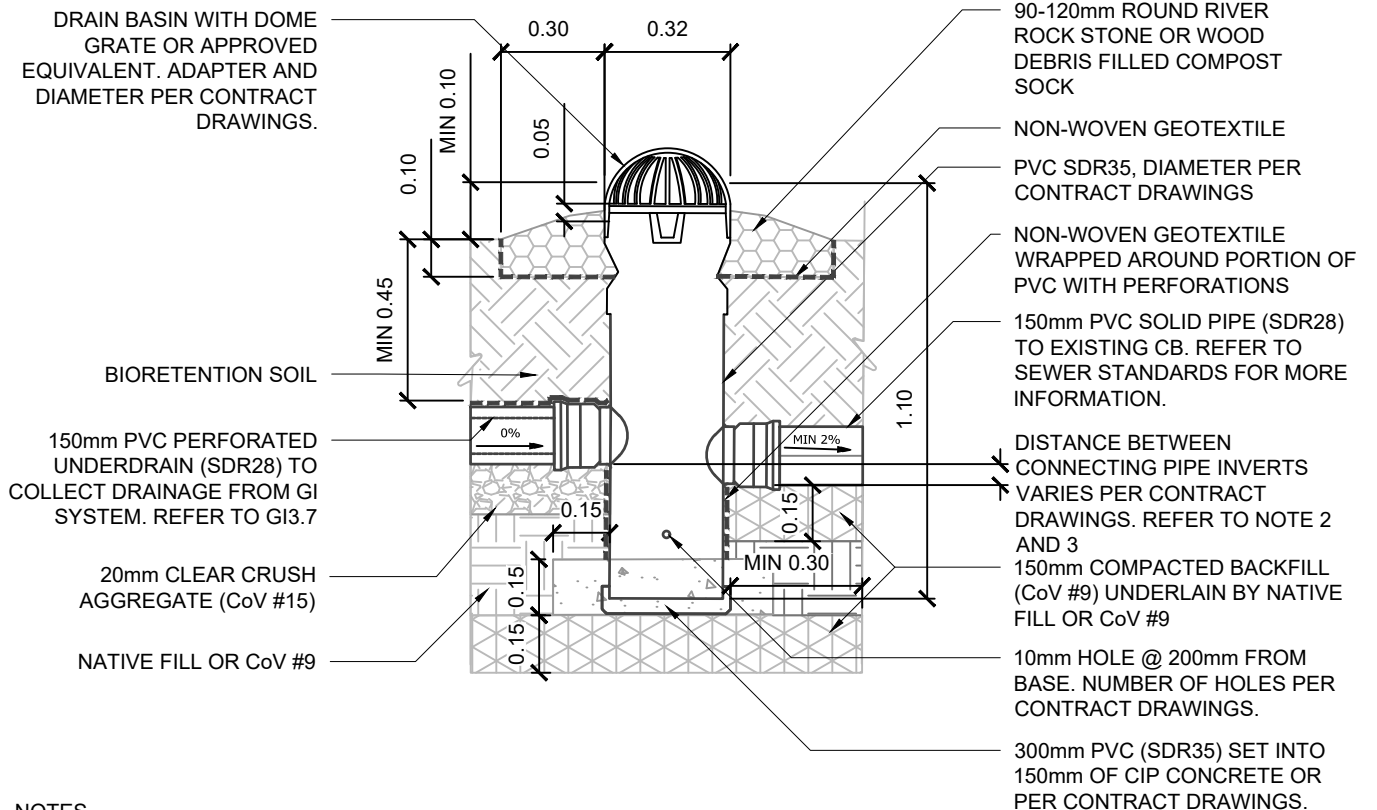

DRAIN BASIN WITH DOME GRATE OR APPROVED EQUIVALENT. ADAPTER AND DIAMETER PER CONTRACT DRAWINGS.

90-120mm ROUND RIVER ROCK STONE OR WOOD DEBRIS FILLED COMPOST SOCK

NON-WOVEN GEOTEXTILE

PVC SDR35, DIAMETER PER CONTRACT DRAWINGS

NON-WOVEN GEOTEXTILE WRAPPED AROUND PORTION OF PVC WITH PERFORATIONS

150mm PVC SOLID PIPE (SDR28) TO EXISTING CB. REFER TO SEWER STANDARDS FOR MORE INFORMATION.

DISTANCE BETWEEN CONNECTING PIPE INVERTS VARIES PER CONTRACT DRAWINGS. REFER TO NOTE 2 AND 3

150mm COMPACTED BACKFILL (CoV #9) UNDERLAIN BY NATIVE FILL OR CoV #9

10mm HOLE @ 200mm FROM BASE. NUMBER OF HOLES PER CONTRACT DRAWINGS.

300mm PVC (SDR35) SET INTO 150mm OF CIP CONCRETE OR PER CONTRACT DRAWINGS.

BIORETENTION SOIL

150mm PVC PERFORATED UNDERDRAIN (SDR28) TO COLLECT DRAINAGE FROM GI SYSTEM. REFER TO GI3.7

20mm CLEAR CRUSH AGGREGATE (CoV #15)

NATIVE FILL OR CoV #9

NOTES

1. THIS CB MAY NOT BE USED IN LIEU OF A SEWERS STANDARD CB OR TO INCREASE THE MAXIMUM CONTRIBUTING DRAINAGE AREA TO A SEWERS CB
2. IF THE PERFORATED PIPE IS TO BE USED AS A DISTRIBUTION PIPE TO CONVEY WATER INTO THE GI SYSTEM, THE INVERT SHOULD BE PLACED BELOW THE INVERT OF THE SEWER CONNECTION.
3. USE OF THIS PVC CB IS DEPENDENT ON APPROVAL FROM CITY OF VANCOUVER SEWERS AND DRAINAGE DESIGN AND GREEN INFRASTRUCTURE IMPLEMENTATION BRANCHES
4. DRAIN BASIN WITH DOME GRATE AND PVC. DIAMETER PER CONSTRUCTION DRAWINGS

| REV. | REVISION DATE | APPROVED |
|------|---------------|----------|
| | | |
| | | |
| | | |

GENERAL COMPONENTS
PVC CATCHBASIN

ISSUE DATE: FEBRUARY 2026

APPROVED BY: N. MEAD-FOX