

To expedite electrical permit reviews and enhance permit application submissions, the New Electrical Load Installation form (NELI) **must** be provided to City Staff for existing multi-unit buildings, of five or more units, pursuant to the following:

- Electrification of existing fuel combustion space heating and domestic hot water systems,
- New electric heating, ventilation, air conditioning systems (HVAC),
- New electric vehicle charging systems, and
- Installation of new or modification of other electrical loads (in excess of 3000 watts within unit).

The NELI is not required:

- When reducing net loads, such as removing baseboard heaters and switching to heat pumps, provided the net load is reduced.

The single line diagram(s) **must** be provided and **must** include such information (where applicable) as:

- Existing consumer's service and distribution affected by proposed new additional loads,
- Proposed distribution equipment including overcurrent protection and conductor sizing of new additional loads,
- Components of any Energy Management System, if applicable.
- Hand-drawn single line diagrams are acceptable.

Load calculation(s) **must** be provided and **must** include such information (where applicable) as:

- Existing and upgraded consumer's service ratings, ratings of feeders and branch circuits,
- Increased electrical load,
- Where an Energy Management System is used, provide explanation of how it can manage the net additional load increase and fail-safe mechanisms,
- Remaining electrical capacity after the installation is complete.

Note: Electrical load calculations are only required to be applied in dwelling units where new loads are being added.

The following form (NELI) **must** be submitted to City Staff under an electrical permit, at the time of installation of new electrical loads as per the above.

Note: A customer cannot increase the electrical load at their premises by more than 15kW or 20%, whichever is greater, without prior approval from BC Hydro. Additionally, the total load must not exceed 80% of the rated capacity of the customer's main switch. Any increase beyond these limits requires advance approval from BC Hydro. (See BC Hydro Electric Tariff Section 7.1)

| | |
|---|------------------------------------|
| Revision/Submission Date <i>(City use only)</i> | Review Date <i>(City use only)</i> |
| | |

Property and Company Details

| | | |
|---|---|------------|
| Date NELI created <i>(DD/MM/YYYY)</i> | Annual Operating Permit Number <i>(If Applicable)</i> | |
| | | |
| Building address | | |
| | | |
| Proposed work - <i>Provide detail on the proposed work to be completed. Include existing systems that are to be modified and any expected challenges.</i> | | |
| | | |
| Building common name <i>(If Applicable)</i> | Strata # <i>(If Applicable)</i> | Year built |
| | | |
| Occupancy <i>(Residential, Commercial, Mixed Use)</i> | Floors | Units |
| | | |

We, *(fill in the name and number of your strata plan, if applicable, here)*,

| | |
|--|---|
| | Approve the proposed scope of work within the current electrical capacity of the building and acknowledge that additional installations may restrict the future electrical capacity of the building(s) and addition of new loads may not be possible in the future. |
| | Acknowledge that the City of Vancouver requires electrical permits ¹ for the installation of new equipment as well as an electrical annual operating permit ² for the management of the strata buildings overall electric system. An overview of the electrical operating permit can be found here . ³ |

Note: Building Owner or Strata President to check 2 boxes above.

| | | |
|------------------------------------|-------|------|
| Building Owner or Strata President | Email | |
| | | |
| Signature | Phone | Date |
| | | |

Electrical Engineering Firm/Electrical Contractor Contact (Qualified Person)

| | |
|---------------------------------------|----------------|
| Company name | Name |
| | |
| Position | Qualifications |
| | |
| Phone | Email address |
| | |
| Signature for NELI author declaration | |
| | |

¹ vancouver.ca/home-property-development/electrical-permit.aspx

² vancouver.ca/files/cov/2019-003-electrical-annual-permit-operating-permit.pdf

³ vancouver.ca/files/cov/electrical-permit-brochure.pdf

1.0 SERVICE

| | |
|--|--|
| 1.1 EXISTING SERVICE RATING (A) | |
| 1.2 SYSTEM OPERATING VOLTAGE (V, PHASE) | |
| 1.3 HOW WAS EXISTING LOAD CALCULATED? <i>(Ex. BC Hydro kWh data with application of safety factor, calculated by applicable rules of Canadian Electrical Code [must cite rules referenced])</i> | |
| 1.4 EXISTING CALCULATED LOAD USING DEMAND FACTORS OR KW PEAK (kW) | |
| 1.5 NEW ADDITIONAL LOADS (kW) | |
| 1.6 LIST OF NEW ADDITIONAL LOADS | |
| 1.7 NEW TOTAL CALCULATED LOAD (kW) | |
| 1.8 REMAINING CAPACITY AFTER INSTALL (kW) | |

2.0 FEEDER

| | |
|--|--|
| 2.1 EXISTING FEEDER RATING (A) | |
| 2.2 SYSTEM OPERATING VOLTAGE (V, PHASE) | |
| 2.3 HOW WAS EXISTING LOAD CALCULATED? <i>(Ex. BC Hydro kWh data with application of safety factor, calculated by applicable rules of Canadian Electrical Code [must cite rules referenced])</i> | |
| 2.4 EXISTING CALCULATED LOAD USING DEMAND FACTORS OR KW PEAK (kW) | |
| 2.5 NEW ADDITIONAL LOADS (kW) | |
| 2.6 LIST OF NEW ADDITIONAL LOADS | |
| 2.7 NEW TOTAL CALCULATED LOAD (kW) | |
| 2.8 REMAINING CAPACITY AFTER INSTALL (kW) | |

3.0 ADDITIONAL FEEDER (IF REQUIRED)

| | |
|--|--|
| 3.1 EXISTING FEEDER RATING (A) | |
| 3.2 SYSTEM OPERATING VOLTAGE (V, PHASE) | |
| 3.3 HOW WAS EXISTING LOAD CALCULATED? <i>(Ex. BC Hydro kWh data with application of safety factor, calculated by applicable rules of Canadian Electrical Code [must cite rules referenced])</i> | |
| 3.4 EXISTING CALCULATED LOAD USING DEMAND FACTORS OR KW PEAK (kW) | |
| 3.5 NEW ADDITIONAL LOADS (kW) | |
| 3.6 LIST OF NEW ADDITIONAL LOADS | |
| 3.7 NEW TOTAL CALCULATED LOAD (kW) | |
| 3.8 REMAINING CAPACITY AFTER INSTALL (kW) | |

BC Hydro kW Peak Data - BC Hydro kW Spreadsheet must be attached to this document when using that data set. [Special Permission](#) to deviate from CE Code Rule 8-106 (8) to use kWh peak in lieu of kW peak required (if applicable).

4.0 SINGLE LINE DIAGRAM (SLD) FOR AFFECTED SERVICE + FEEDER (DISTRIBUTION)

A single line diagram is required for the affected service and feeder (distribution).

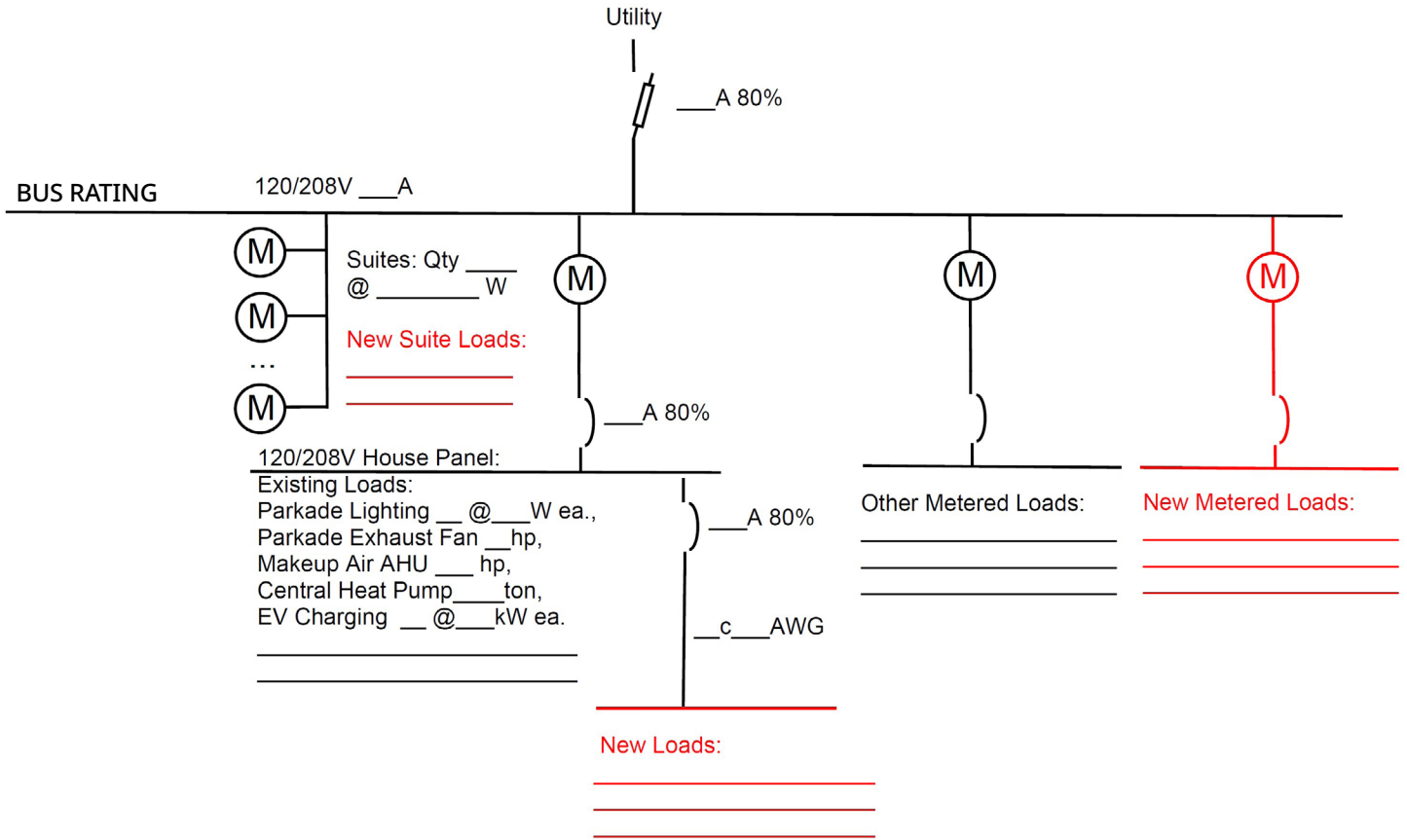

Reference SLD – Red Indicates New Additional Loads

5.0 LOAD MITIGATING STRATEGIES (where applicable)

Note: If an Energy Management System is used, briefly describe how the system operates, including any fail-safe mechanisms and how proper operation is ensured for safety, performance, testing and maintenance purposes under the applicable standards and intended use of the approved equipment.

| | |
|--|--|
| <p>List steps, if any, that the strata or building owner plan to undertake to limit the electrical demand.</p> | |
| <p>List upgrades or modifications, if any, to the electrical system that the strata or building owner plan to undertake to increase the available capacity of the electrical system.</p> | |
| <p>If an Energy Management System is proposed, provide a detailed explanation of how it can manage the net load increase and describe its fail-safe mechanisms.</p> | |
| <p>Provide an estimate of the remaining electrical capacity after application of load mitigating strategies as referenced in the questions above.</p> | |