

GREEN INFRASTRUCTURE DETAILS

Sheet Number	Drawing Title	Description
GI0.1	DRAWING INDEX	GREEN INFRASTRUCTURE DETAILS
GI0.2	DRAWING INDEX	GREEN INFRASTRUCTURE DETAILS
GI1.1	GENERAL INFORMATION	USER GUIDE
GI2.0	INLETS AND OUTLETS	INLETS AND OUTLETS DESIGN GUIDANCE
GI2.1	INLETS AND OUTLETS	STRAIGHT STEEL INLET COVER
GI2.2	INLETS AND OUTLETS	CURVED STEEL INLET COVER
GI2.3	INLETS AND OUTLETS	OPEN CURB CUT INLET
GI2.4	INLETS AND OUTLETS	COVERED CURB CUT INLET
GI2.5	INLETS AND OUTLETS	PRETREATMENT SEDIMENT PAD
GI2.6	INLETS AND OUTLETS	PRETREATMENT SEDIMENT BASIN
GI3.0	GENERAL COMPONENTS	GI COMPONENTS DESIGN GUIDANCE
GI3.1	GENERAL COMPONENTS	GI OFFSET CATCHBASIN
GI3.2	GENERAL COMPONENTS	MONITORING WELL
GI3.3	GENERAL COMPONENTS	INSPECTION CHAMBER
GI3.4	GENERAL COMPONENTS	GI CLEANOUT
GI3.5	GENERAL COMPONENTS	TREE TRENCH CURB EDGES
GI3.6	GENERAL COMPONENTS	GI BANDING
GI3.7	GENERAL COMPONENTS	UNDERDRAINS AND DISTRIBUTION PIPES
GI3.8	GENERAL COMPONENTS	PVC CATCHBASIN
GI4.0A	BIORETENTION	DESIGN NOTES AND GUIDANCE
GI4.0B	BIORETENTION	BIORETENTION DRAWING DESCRIPTIONS
GI4.1	BIORETENTION	BIORETENTION PROFILE
GI4.2	BIORETENTION	BIORETENTION BULGE WITHOUT ADJACENT BOULEVARD
GI4.3	BIORETENTION	BIORETENTION BULGE WITH ADJACENT BOULEVARD
GI4.4	BIORETENTION	CURB CUT SEDIMENT BASIN
GI4.5	BIORETENTION	STRAIGHTAWAY SEDIMENT PAD
GI4.6	BIORETENTION	SEDIMENT BASIN WEIR WALL
GI4.7	BIORETENTION	CONCRETE CHECK DAM
GI5.0A	RAINWATER TREE TRENCHES	DESIGN NOTES AND GUIDANCE
GI5.0B	RAINWATER TREE TRENCHES	RTT DRAWING DESCRIPTIONS
GI5.1	RAINWATER TREE TRENCHES	RAINWATER TREE TRENCH LAYOUT
GI5.2	RAINWATER TREE TRENCHES	RTT INSPECTION CHAMBER
GI5.3	RAINWATER TREE TRENCHES	STRUCTURAL SOIL ADJACENT TO GI
GI5.4	RAINWATER TREE TRENCHES	GI SWALE BOULEVARD WITH STREET TREES
GI5.5	RAINWATER TREE TRENCHES	GI TREE PIT WITH STRUCTURAL SOIL
GI5.6	RAINWATER TREE TRENCHES	GI TREE PIT WITH DISTRIBUTION PIPE
GI5.7	RAINWATER TREE TRENCHES	VERTICAL EDGE RTT CROSS-SECTIONS

REV.	REVISION DATE	APPROVED

DRAWING INDEX
GREEN INFRASTRUCTURE DETAILS

ISSUE DATE: FEBRUARY 2026
APPROVED BY: N. MEAD-FOX

GREEN INFRASTRUCTURE DETAILS

Sheet Number	Drawing Title	Description
GI6.0A	INFILTRATION SYSTEMS	DESIGN NOTES AND GUIDANCE
GI6.0B	INFILTRATION SYSTEMS	DRAWING DESCRIPTIONS
GI6.1	INFILTRATION SYSTEMS	BOULEVARD INFILTRATION TRENCH
GI6.2	INFILTRATION SYSTEMS	BOULEVARD DRY WELL
GI6.3	INFILTRATION SYSTEMS	RIGHT OF WAY INFILTRATION TRENCH
GI7.0A	BIOSWALES	DESIGN NOTES AND GUIDANCE
GI7.0B	BIOSWALES	BIOSWALE DRAWING DESCRIPTIONS
GI7.1	BIOSWALES	BIOSWALE - NO ROAD DRAINAGE
GI7.2	BIOSWALES	BIOSWALE - RECEIVING ROAD DRAINAGE

REV.	REVISION DATE	APPROVED

DRAWING INDEX
GREEN INFRASTRUCTURE DETAILS

ISSUE DATE: FEBRUARY 2026
APPROVED BY: N. MEAD-FOX

USER GUIDE: GI TYPICAL DETAILS

THESE TYPICAL DETAILS AND SPECIFICATIONS WERE DEVELOPED TO BE REVISED AND CUSTOMIZED FOR EACH INDIVIDUAL PROJECT BY DESIGN PROFESSIONALS. AUTOCAD FILES OF THESE DETAILS CAN BE PROVIDED UPON REQUEST TO THE GREEN INFRASTRUCTURE IMPLEMENTATION (GII) BRANCH (GREEN.INFRASTRUCTURE@VANCOUVER.CA).

THEY SHOW TYPICAL CONFIGURATIONS, RATHER THAN A REQUIRED CITY STANDARD CONFIGURATION. THIS DISTINCTION IS DELIBERATE. WE RECOGNIZE THAT TO CREATE GI PROJECTS THAT ARE FUNCTIONAL, CONTEXTUAL, AND AESTHETIC, DESIGN PROFESSIONALS MUST USE THEIR PROFESSIONAL JUDGMENT AND CREATIVE THINKING TO BE RESPONSIVE TO EACH SITE-SPECIFIC CONDITION.

REFERENCES ARE MADE THROUGHOUT THESE STANDARD DRAWINGS TO THE "DESIGN MANUAL", OTHER DRAWINGS, AND STANDARD CITY OF VANCOUVER CONSTRUCTION MATERIALS. THE DESIGN MANUAL REFERS TO THE GREEN INFRASTRUCTURE AND INTEGRATED RAINWATER MANAGEMENT CHAPTER OF THE CITY OF VANCOUVER ENGINEERING DESIGN MANUAL. GI STANDARD DRAWINGS ARE REFERRED TO BY THEIR DRAWING TITLE (i.e GI4.3). AGGREGATE MATERIALS ARE REFERRED TO BY THEIR CITY OF VANCOUVER DESIGNATION (i.e. COV #9)

CONTENT

THESE TYPICAL DETAILS ARE FORMATTED, ORGANIZED, AND DEVELOPED WITH THE NECESSARY INFORMATIONAL TOOLS TO GUIDE THE DESIGN PROFESSIONAL THROUGH THE PROPER SELECTION, LAYOUT, AND DESIGN OF GI PRACTICES AND THE SELECTION OF APPROPRIATE SITE-SPECIFIC COMPONENTS DETAILS (I.E. INLETS, OUTLETS, AND EDGE TREATMENTS, ETC.).

- PURPOSE: SUMMARY OF EACH FACILITY'S INTENDED PERFORMANCE AND FUNCTION.
- DESIGNER NOTES & GUIDELINES: TECHNICAL DESIGN REQUIREMENTS AND/OR SIZING CRITERIA GUIDELINES ARE PROVIDED SUCH THAT EACH FACILITY IS DESIGNED AND APPROPRIATELY CUSTOMIZED BY THE DESIGN PROFESSIONAL.
- LAYOUT REQUIREMENTS: TECHNICAL INFORMATION, DESIGN REQUIREMENTS, AND REFERENCE TO RELATED CITY REQUIREMENTS.
- DESIGNER CHECKLIST: TECHNICAL DESIGN INFORMATION THAT MUST BE DETERMINED AND SHOWN IN THE CONSTRUCTION DOCUMENTS TO ENSURE PROPER DESIGN AND CONSTRUCTABILITY.
- BMP PLANS: TYPICAL PLAN VIEW WITH GENERAL CONFIGURATION FOR PROPER FUNCTION. DIMENSIONAL LAYOUT AND EDGING MATERIALS SHOULD BE ADJUSTED BASED ON PROPOSED SITE DESIGN AND PROGRAMING.
- BMP SECTIONS AND PROFILES: A TYPICAL SECTION AND/OR PROFILE WITH GENERAL CONFIGURATION FOR PROPER FUNCTION. DIMENSIONAL LAYOUT AND EDGING MATERIALS SHOULD BE ADJUSTED BASED ON PROPOSED SITE DESIGN AND PROGRAMING.
- CONSTRUCTION NOTES: CONSTRUCTION RELATED NOTES FOR USE BY THE CONTRACTOR.
- DETAILS FOR INDIVIDUAL COMPONENTS SUCH AS INLETS, SEDIMENT PADS, PERFORATED PIPES, MONITORING WELLS, AND MORE

USE ON CONSTRUCTION DOCUMENTS

DESIGN PROFESSIONALS USING THE AUTOCAD DRAWINGS MUST REVIEW AND ADJUST THE DETAILS AND CONSTRUCTION NOTES TO ADDRESS THEIR SITE-SPECIFIC CONDITIONS . TO ALLOW FOR SITE-SPECIFIC DESIGN ADJUSTMENTS THE TYPICAL DETAILS ARE DEVELOPED AS "NOT FOR CONSTRUCTION" DRAWINGS. TITLE BLOCKS ARE PROVIDED FOR DOCUMENT ORGANIZATION AND REFERENCE ONLY. DRAWINGS THAT DO NOT REQUIRE ADJUSTMENT CONTAIN THE FOLLOWING NOTE: "FIXED: THIS DETAIL MAY BE REFERENCED ON ENGINEERING DRAWINGS WITHOUT AN ADJUSTED SITE-SPECIFIC DETAIL" .

- DO NOT INCLUDE THE NON-ADJUSTED DETAIL WITH TITLE BLOCK WITHIN THE CONSTRUCTION DOCUMENTS.
- DO NOT INCLUDE NON-ADJUSTED DETAIL PLANS, SECTIONS, OR CONSTRUCTION NOTES WITHIN THE CONSTRUCTION DOCUMENTS.
- DO NOT REFERENCE THE GI TYPICAL DETAIL SHEET NAME AND/OR NUMBER (i.e. GI 2.1) AS A STANDARD DETAIL CALL-OUT ON DRAWINGS.
- DO NOT EXPECT CONTRACTORS TO CONDUCT CALCULATIONS OR BE RESPONSIBLE FOR MISSING DESIGN INFORMATION.

NOTE: ALL UNITS ARE IN METERS UNLESS OTHERWISE NOTED

			GENERAL INFORMATION USER GUIDE	ISSUE DATE: FEBRUARY 2026
				APPROVED BY: <u>N. MEAD-FOX</u>
REV.	REVISION DATE	APPROVED		

GI INLETS AND OUTLETS DESIGN NOTES AND GUIDANCE

PURPOSE:

THE FOLLOWING DETAILS PROVIDE DESIGN ALTERNATIVES FOR CONVEYING WATER INTO AND OUT OF ROADSIDE GREEN INFRASTRUCTURE SYSTEMS. CAD FILES OF THESE DETAILS CAN BE PROVIDED UPON REQUEST TO THE GREEN INFRASTRUCTURE IMPLEMENTATION BRANCH (GREEN.INFRASTRUCTURE@VANCOUVER.CA).

DESIGNER NOTES & GUIDELINES:

1. ALL DIMENSIONS ARE IN METERS UNLESS OTHERWISE NOTED.
2. THE DESIGNER MUST SIZE INLETS AND OUTLETS PER DESIGN GUIDANCE INCLUDED IN THE GI DESIGN MANUAL.
3. GI SYSTEMS WITH INTERNAL CATCHBASINS CONNECTED TO MUNICIPAL SEWERS SHOULD BE DESIGNED TO ACCOMMODATE THE FULL DESIGN FLOW OF THE RECEIVING SEWER.
4. INLETS FOR GI SYSTEMS THAT ARE NOT DIRECTLY CONNECTED TO MUNICIPAL SEWER SYSTEMS SHOULD BE DESIGNED TO ACCOMMODATE THE PEAK FLOW OF THE 24hr 48mm GI DESIGN STORM.
5. ALL GI INLETS SHOULD BE DESIGNED WITH A SAFETY FACTOR OF 1.5.

STANDARD DRAWING DESCRIPTIONS

2.1.	STRAIGHT STEEL INLET COVER	THE STRAIGHT STEEL CURB INLET COVER IS A STEEL COVER THAT PROVIDES A CONTINUOUS, FLUSH TOP-OF-CURB SURFACE OVER A CURB CUT. GI2.1 AND GI2.2 ARE OFTEN PAIRED WITH GI4.5.
2.2.	CURVED STEEL INLET COVER	THE CURVED STEEL CURB INLET IS A MODIFICATION OF THE STRAIGHT STEEL COVER INLET USED TO COVER CURB CUTS ON A ROADWAY BULGE.
2.3.	OPEN CURB CUT INLET	GI2.3. SHOWS THE CURB AND GUTTER GEOMETRY FOR A ROADSIDE CURB CUT INLET WITHOUT A STEEL COVER. INTENDED FOR LOWER TRAFFIC AREAS OR AREAS WITHOUT STREET PARKING.
2.4.	COVERED CURB CUT INLET	GI2.4 IS A SIMILAR DESIGN TO GI2.3 BUT WITH A STEEL INLET COVER SUCH AS THOSE SHOWN IN GI2.1 AND GI2.2. THIS TYPE OF CURB INLET MAY ALSO BE PAIRED WITH A SEDIMENT CONTROL FEATURE SUCH AS THOSE SHOWN IN GI4.4 AND GI4.5.
2.5.	PRETREATMENT SEDIMENT PAD	PRETREATMENT SEDIMENT PADS ARE PLACED DOWNSTREAM OF A CURB CUT INLET AND ARE USED TO PREVENT EROSION OF BIORETENTION MEDIA AND REDUCE SEDIMENT ENTERING INTO GREEN INFRASTRUCTURE ASSETS. THEY MAY BE INSTALLED IMMEDIATELY DOWNSTREAM OF THE CURB CUT OPENING OF BIORETENTION SYSTEMS OR TREE TRENCHES. INTENDED FOR SMALLER DRAINAGE AREAS, SUCH AS THE DOWNSTREAM INLETS OF A BIORETENTION SYSTEM.
2.6.	PRETREATMENT SEDIMENT BASIN	PRETREATMENT SEDIMENT BASINS HAVE A SIMILAR FUNCTION AND ARE PLACED IN SIMILAR LOCATIONS TO SEDIMENT PADS, BUT THEY ARE INTENDED FOR LARGER CONTRIBUTING DRAINAGE AREAS AND HIGHER SEDIMENT LOADS, SUCH AS THE MOST UPSTREAM INLET OF A BIORETENTION SYSTEM.

DESIGNER CHECKLIST (MUST SPECIFY, AS APPLICABLE):

- INLET WIDTH AND LENGTH
- CROSS-SLOPE AND LONGITUDINAL SLOPE
- INLET CAPACITY DURING SEWERS DESIGN STORM (DEPTH OF FLOW AT DESIGN STORM PEAK FLOW)
- DOWNSTREAM PRETREATMENT COMPONENTS

LAYOUT REQUIREMENTS:

1. REFER TO THE CITY OF VANCOUVER ACCESSIBILITY STRATEGY, STANDARD DRAWINGS AND CONSTRUCTION SPECIFICATIONS FOR RIGHT-OF-WAY, PARKING SPACE, AND ACCESSIBLE PATH REQUIREMENTS.
2. LOCATE CURB CUTS AND GUTTER MODIFICATIONS TO AVOID CONFLICTS WITH ACCESSIBILITY REQUIREMENTS (E.G., LOCATE OUTSIDE OF CROSSWALKS).

REV.	REVISION DATE	APPROVED

**INLETS AND OUTLETS
INLETS AND OUTLETS DESIGN GUIDANCE**

ISSUE DATE: FEBRUARY 2026
APPROVED BY: N. MEAD-FOX

700mm INLET PARTS LIST						
ITEM	QTY	PART #	MATERIAL	LENGTH	WIDTH	HEIGHT
①	1	STEEL CURB INLET	12.7mm THK. 300W STEEL	1337.1	150	250
②	2	SUPPORT STRIP	12.7mm THK. 300W STEEL	649.2	12.7	40
1000mm INLET PARTS LIST						
①	1	1000mm STEEL CURB INLET	12.7mm THK. 300W STEEL	1637.1	150	250
②	2	STEEL STRIP FOR 1000mm INLET	12.7mm THK. 300W STEEL	949.2	12.7	60

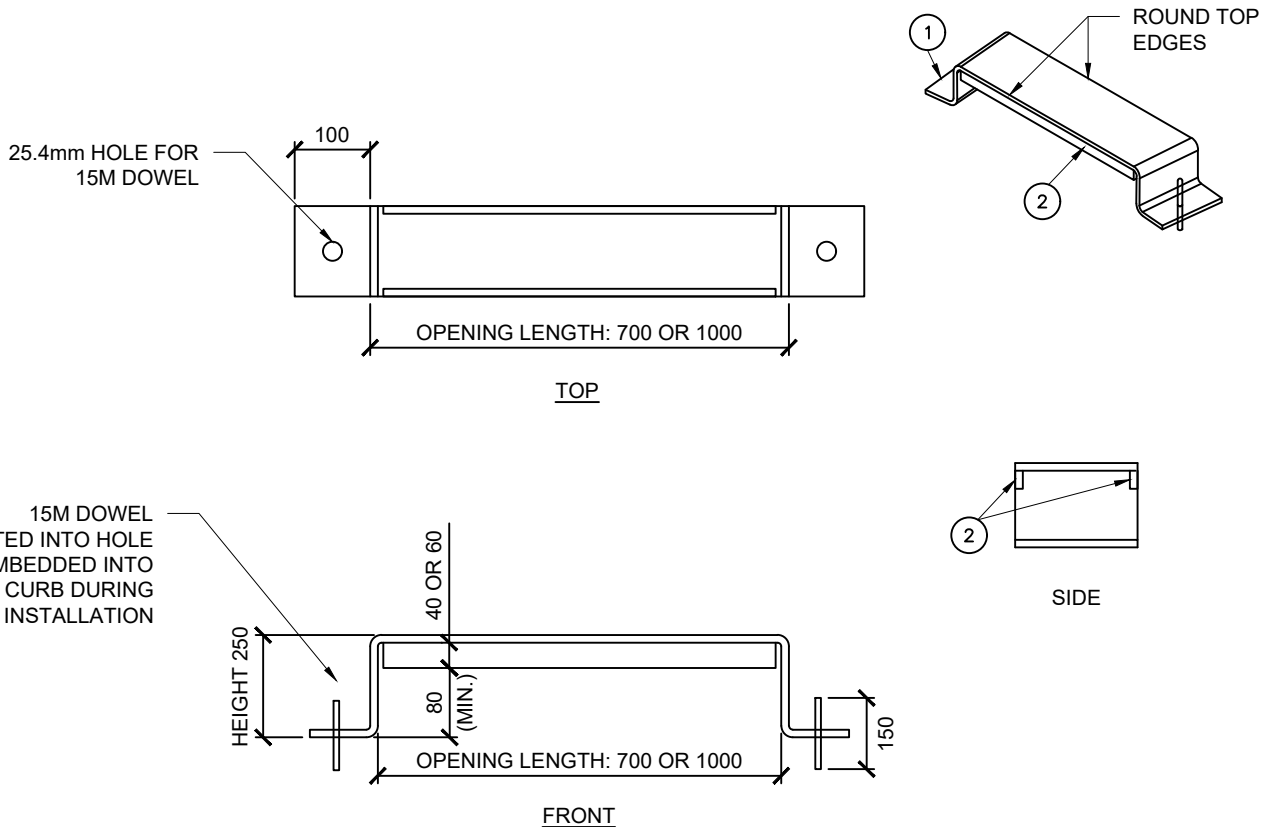

NOTES:

1. ALL DIMENSIONS IN MILLIMETERS.
2. ENSURE NO SHARP EDGES.
3. STEEL INLET COVER TO BE 20mm GREATER THAN THE HEIGHT OF THE CURB FACE TO ACCOUNT FOR GUTTER PAN DEPRESSION.
4. DESIGN CRITERIA, APPLIED LOADING CONSTRAINTS, AND MAXIMUM VERTICAL POINT LOADING FOR VARIOUS COVER WIDTHS MAY BE PROVIDED UPON REQUEST.
5. PROVIDE STEEL IN CONFORMANCE WITH CITY OF VANCOUVER CONSTRUCTION SPECIFICATIONS.
6. STRUCTURAL MEMBER SIZING AND ORIENTATION OF ELEMENT TO BE CONFIRMED BY THE ENGINEER.
7. SUPPORT STRIP HEIGHT MAY BE INCREASED TO 80mm IN AREAS WITH A HIGH LIKELIHOOD OF VEHICLE LOADING
8. STEEL INLET COVERS MUST BE PURCHASED FROM THE CITY OF VANCOUVER - MAINTENANCE AND ENGINEERING SUPPORT TEAM

MAXIMUM DESIGN STORM PEAK FLOW (m ³ /s)	OPENING LENGTH (mm)	SUPPORT STRIP LENGTH (mm)	SUPPORT STRIP HEIGHT (mm)
0.008	700	650	40
0.010	1000	950	60

REV.	REVISION DATE	APPROVED

INLETS AND OUTLETS
STRAIGHT STEEL INLET COVER

ISSUE DATE: FEBRUARY 2026
APPROVED BY: N. MEAD-FOX

700mm INLET PARTS LIST						
ITEM	QTY	PART #	MATERIAL	LENGTH	WIDTH	HEIGHT
①	1	STEEL CURB INLET	12.7mm THK. 300W STEEL	1360.7	150	250
②	1	SUPPORT STRIP	12.7mm THK. 300W STEEL	650.9	12.7	40
1000mm INLET PARTS LIST						
①	1	1000mm STEEL CURB INLET	12.7mm THK. 300W STEEL	1660.7	150	250
②	1	STEEL STRIP FOR 1000mm INLET	12.7mm THK. 300W STEEL	950.9	12.7	60

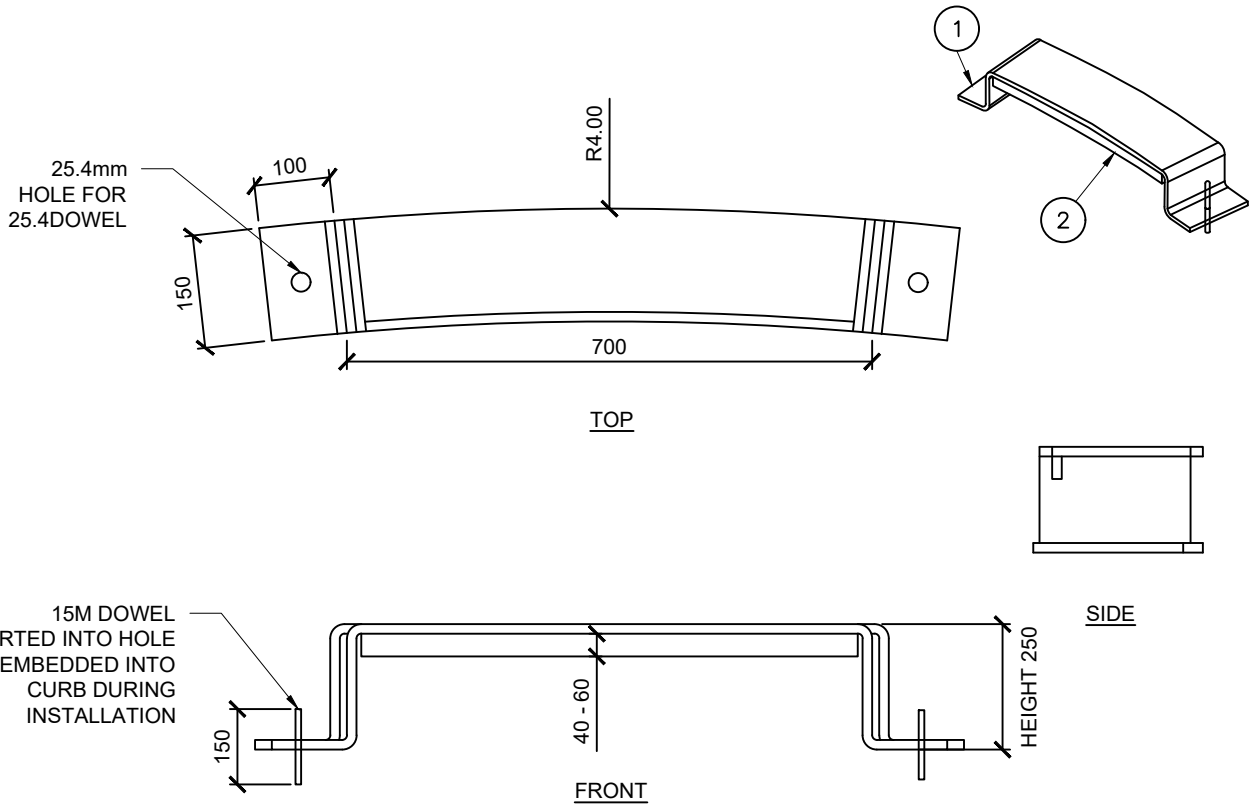

NOTES

1. ALL DIMENSIONS IN MILLIMETERS.
2. ENSURE NO SHARP EDGES.
3. STEEL INLET COVER ARE TO BE 20mm GREATER THAN THE HEIGHT OF THE CURB FACE TO ACCOUNT FOR GUTTER PAN DEPRESSION.
4. DESIGN CRITERIA, APPLIED LOADING CONSTRAINTS, AND MAXIMUM VERTICAL POINT LOADING FOR VARIOUS COVER WIDTHS MAY BE PROVIDED UPON REQUEST.
5. PROVIDE STEEL IN CONFORMANCE WITH CITY OF VANCOUVER CONSTRUCTION SPECIFICATIONS.
6. STRUCTURAL MEMBER SIZING AND ORIENTATION OF ELEMENT TO BE CONFIRMED BY THE ENGINEER.
7. SUPPORT STRIP HEIGHT MAY BE INCREASED TO 80mm IN AREAS WITH A HIGH LIKELIHOOD OF VEHICLE LOADING
8. STEEL INLET COVERS MUST BE PURCHASED FROM THE CITY OF VANCOUVER - MAINTENANCE AND ENGINEERING SUPPORT TEAM

MAXIMUM DESIGN STORM PEAK FLOW (m ³ /s)	OPENING LENGTH (mm)	SUPPORT STRIP LENGTH (mm)	SUPPORT STRIP HEIGHT (mm)
0.008	700	650	40
0.010	1000	950	60

REV.	REVISION DATE	APPROVED

INLETS AND OUTLETS
CURVED STEEL INLET COVER

ISSUE DATE: FEBRUARY 2026
APPROVED BY: N. MEAD-FOX

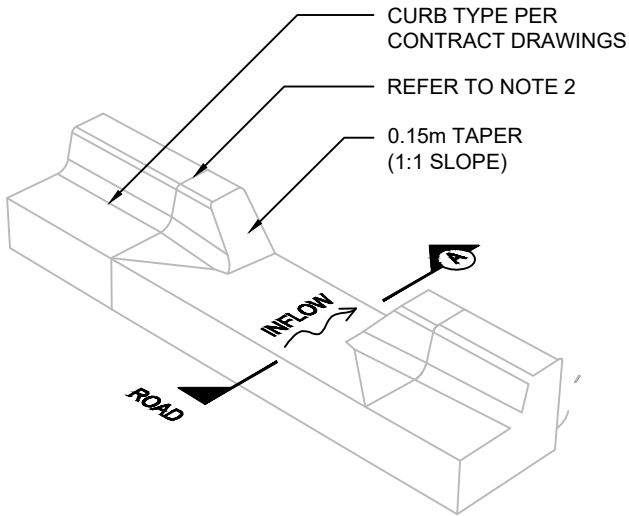

AXONOMETRIC

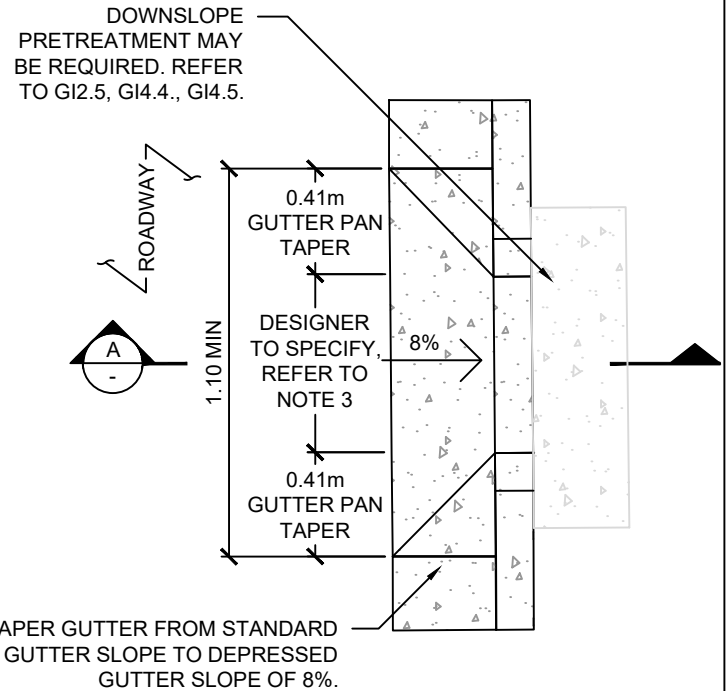

PLAN

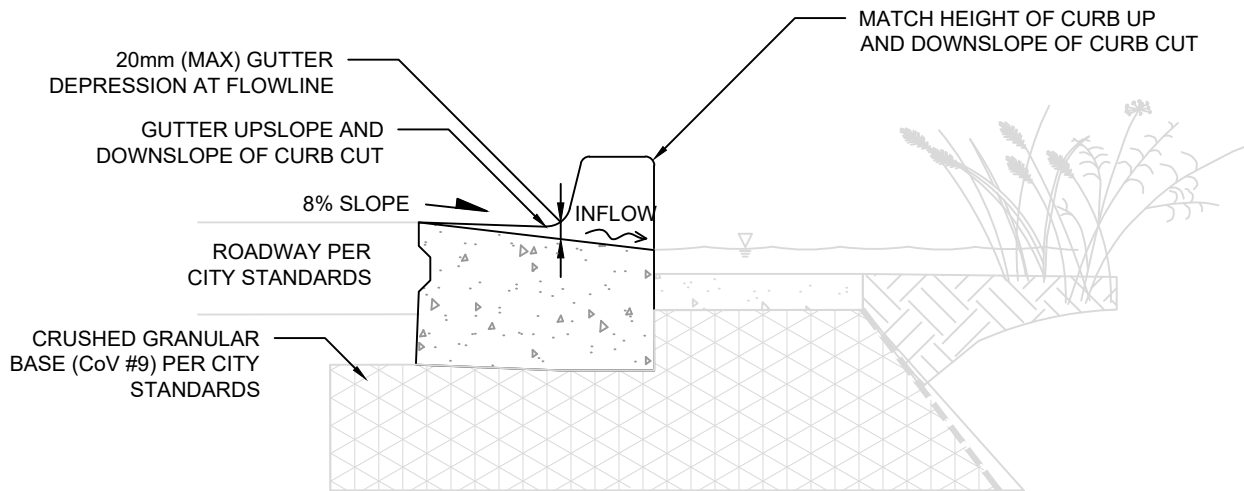

SECTION A

NOTES

1. ALL MATERIAL AND WORKMANSHIP FOR CURB CUTS SHALL CONFORM TO CITY OF VANCOUVER STANDARD SPECIFICATIONS AND GUIDELINES
2. IF CURB CUT CANNOT BE INSTALLED AT CURB CONTROL JOINTS, BOND NEW CURB AND GUTTER TO EXISTING CURB AND GUTTER WITH EPOXY AND DOWEL CONNECTION
3. REFER TO ENGINEERING DESIGN MANUAL FOR GUIDANCE ON DESIGNING INLET CURB CUT WIDTH.
4. REFER TO GI2.5, GI4.4 AND GI4.5 FOR PRETREATMENT SEDIMENT PAD DETAILS

REV.	REVISION DATE	APPROVED

INLETS AND OUTLETS
OPEN CURB CUT INLET

ISSUE DATE: FEBRUARY 2026
APPROVED BY: N. MEAD-FOX

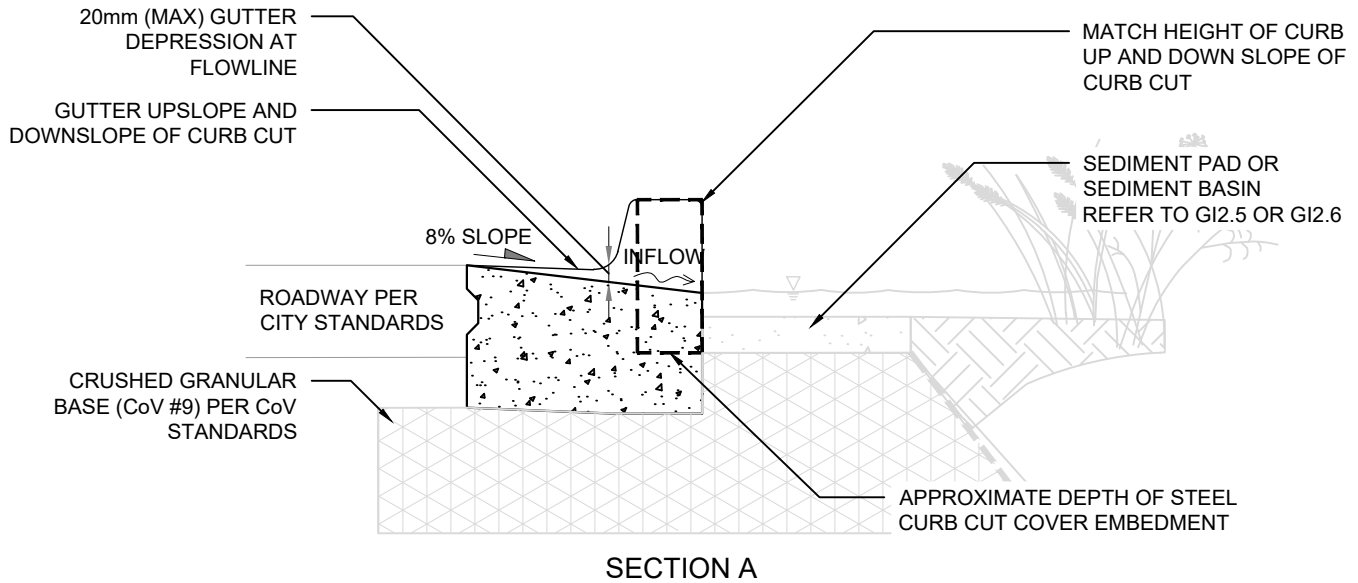
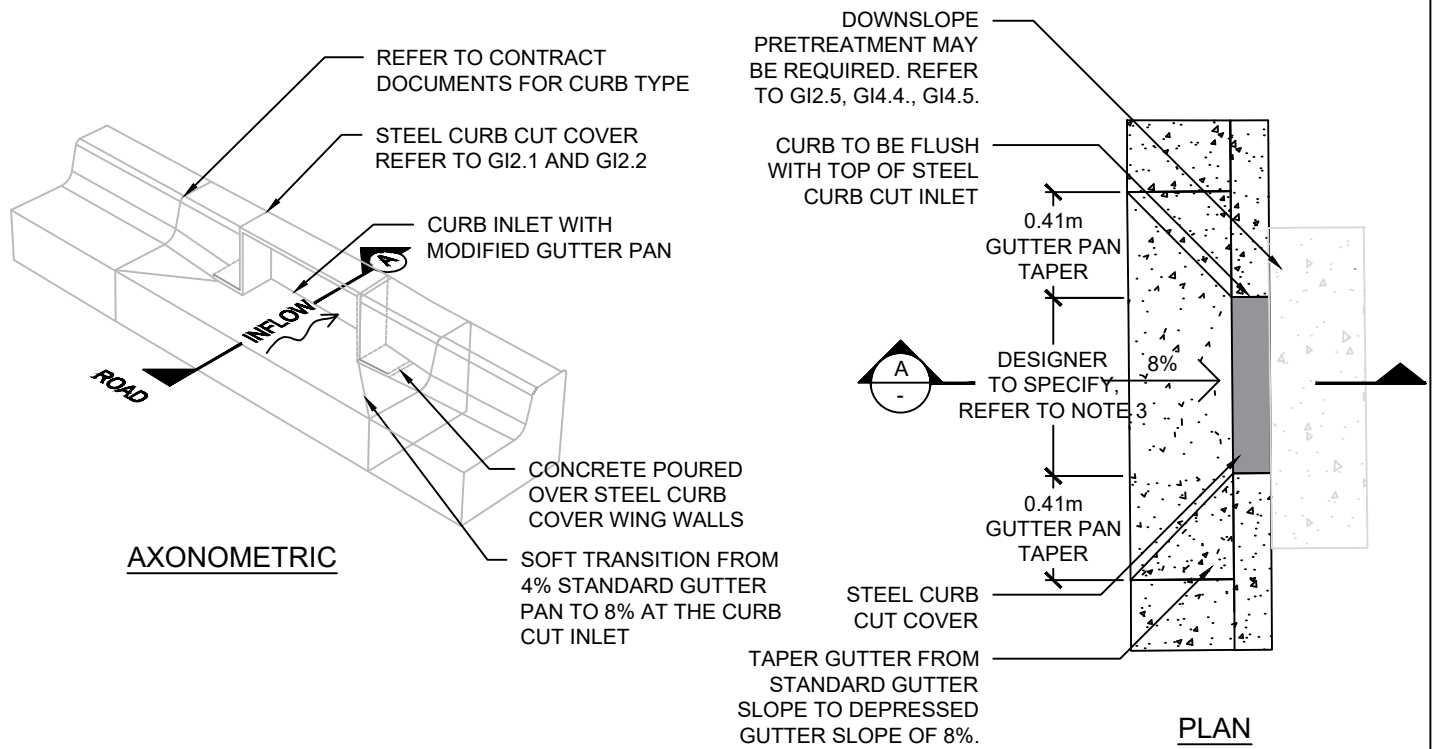

NOTES

1. ALL MATERIAL AND WORKMANSHIP FOR CURB CUTS SHALL CONFORM TO CITY OF VANCOUVER STANDARD SPECIFICATIONS AND GUIDELINES
2. IF CURB CUT CANNOT BE INSTALLED AT CURB CONTROL JOINTS, BOND NEW CURB AND GUTTER TO EXISTING CURB AND GUTTER WITH EPOXY AND DOWEL CONNECTION
3. REFER TO ENGINEERING DESIGN MANUAL FOR GUIDANCE ON DESIGNING INLET CURB CUT WIDTH.
4. CONCRETE TO BE POURED IN PLACE OVER STEEL COVER WING WALLS.
5. REFER TO GI2.5, GI4.4 AND GI4.5 FOR PRETREATMENT SEDIMENT PAD DETAILS

REV.	REVISION DATE	APPROVED

INLETS AND OUTLETS
COVERED CURB CUT INLET

ISSUE DATE: FEBRUARY 2026
APPROVED BY: N. MEAD-FOX

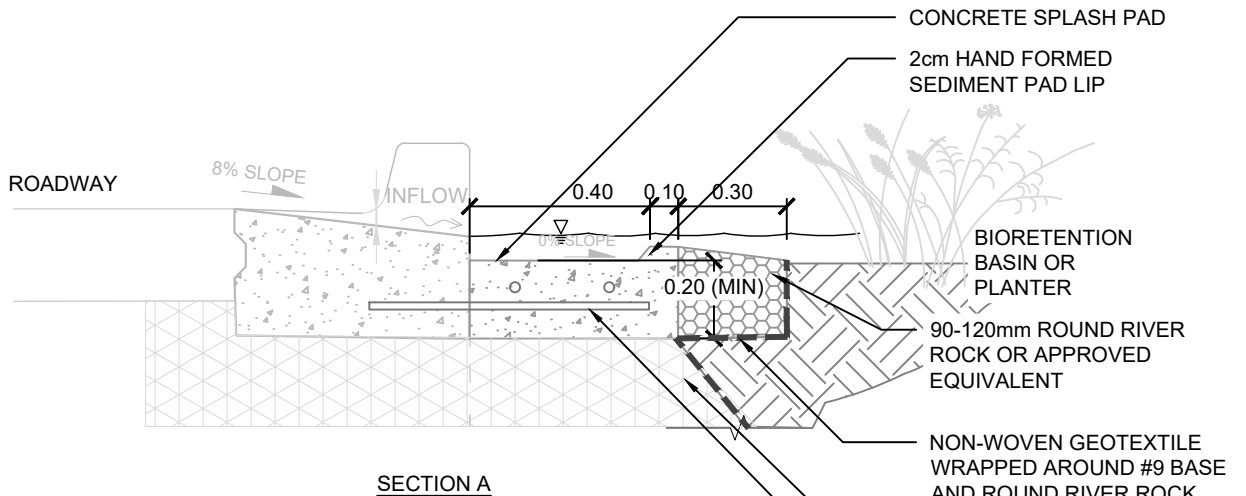
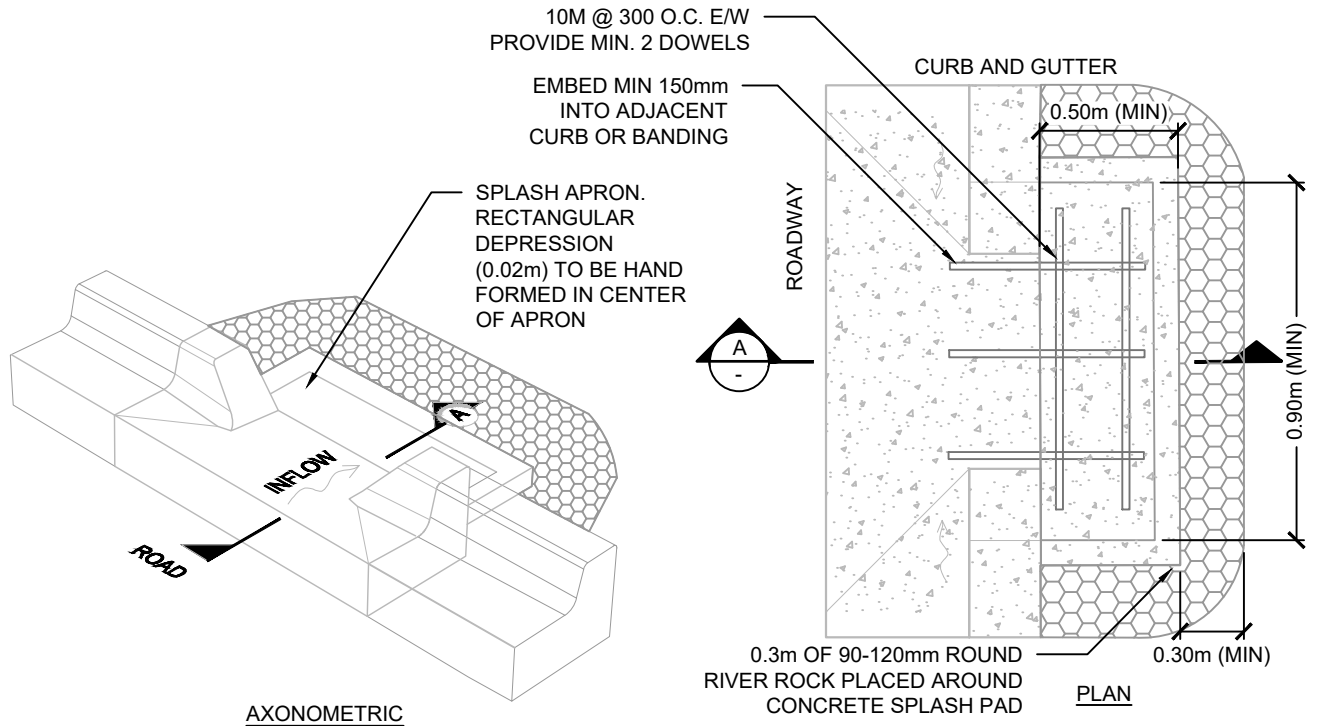

NOTES

1. HAND PACK GROWING MEDIUM AND #9 BASE UNDER AND AROUND THE SEDIMENT PAD TO A DISTANCE OF 0.3m
2. ROUND RIVER ROCK MAY BE REPLACED WITH ALTERNATIVE EROSION AND SEDIMENT CONTROL MEASURES SUCH AS COMPOST SOCKS.
3. ALL MATERIAL AND WORKMANSHIP FOR CURB CUTS SHALL CONFORM TO CITY OF VANCOUVER STANDARD SPECIFICATIONS AND GUIDELINES
4. IF CURB CUT CANNOT BE INSTALLED AT CURB CONTROL JOINTS, BOND NEW CURB AND GUTTER TO EXISTING CURB AND GUTTER WITH EPOXY AND DOWEL CONNECTION.
5. GI2.5. TO BE USED WHEN CONTRIBUTING DRAINAGE AREA IS LESS THAN 100 m². REFER TO GI2.6, GI4.4 AND GI4.5 FOR ALTERNATE PRETREATMENT OPTIONS.

- CONCRETE SPLASH PAD
- 2cm HAND FORMED SEDIMENT PAD LIP
- BIORETENTION BASIN OR PLANTER
- 90-120mm ROUND RIVER ROCK OR APPROVED EQUIVALENT
- NON-WOVEN GEOTEXTILE WRAPPED AROUND #9 BASE AND ROUND RIVER ROCK
- 150mm CoV #9 AGGREGATE BASE BENEATH SEDIMENT PAD EXTENTS
- 10M @ 300 O.C. E/W PROVIDE MIN. 2 DOWELS, EMBED MIN 150mm INTO ADJACENT CURB OR BANDING

REV.	REVISION DATE	APPROVED

**INLETS AND OUTLETS
PRETREATMENT SEDIMENT PAD**

ISSUE DATE: FEBRUARY 2026
APPROVED BY: N. MEAD-FOX

WEIR NOTCH DETAIL

0.01 RADIUS ON ALL WEIR NOTCH EDGES

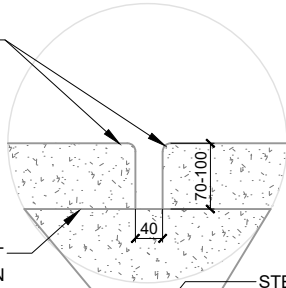

BOTTOM OF SEDIMENT BASIN

STEEL CURB CUT COVER. REFER TO GI2.1.

CIP SEDIMENT BASIN

CURB CUT INLET REFER TO GI2.4

CURB TYPE PER CONTRACT DRAWINGS

AXONOMETRIC

90-120mm ROUND RIVER ROCK STONE. APPROX. 0.30M DEPTH

CIP PRETREATMENT BASIN

TAPER GUTTER FROM STANDARD GUTTER SLOPE TO DEPRESSED GUTTER SLOPE OF 8%.

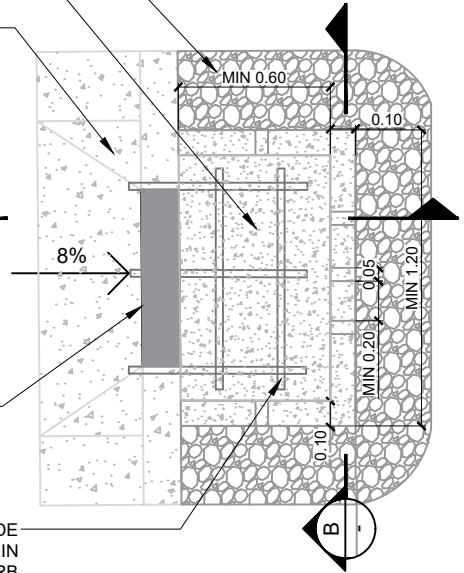
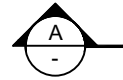

STEEL CURB CUT COVER. REFER TO GI2.1

15M @ 300 O.C. E/W PROVIDE MIN. 2 DOWELS, EMBED MIN 150mm INTO ADJACENT CURB OR BANDING

PLAN

COVERED CURB CUT INLET. REFER TO GI2.4

NEW ROAD CURB WITH BASE THICKENED BY 0.15m

COMPACTED GRANULAR BASE (CoV #9) PER CITY STANDARDS

CIP SEDIMENT BASIN

15M @ 300 O.C. E/W PROVIDE MIN. 2 DOWELS, EMBED MIN 150mm INTO ADJACENT CURB OR BANDING

VEGETATED SLOPE BEYOND INLET AREA DEPENDENT ON SITE CONDITIONS

BIORETENTION SOIL

BOTTOM OF WEIR NOTCH

90-120mm ROUND RIVER ROCK STONE OR APPROVED EQUIVALENT. APPROXIMATE 0.30m DEPTH

SECTION A

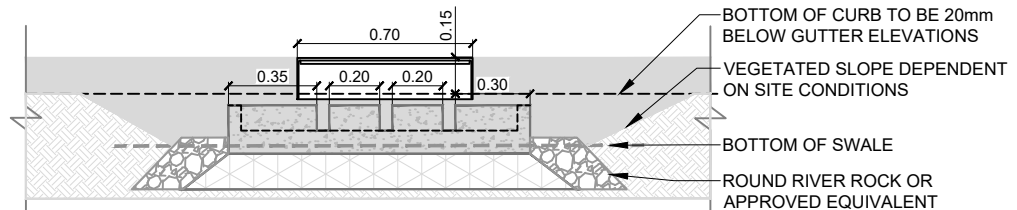

SECTION B

NOTES

1. BOTTOM OF WEIR NOTCHES TO BE FLUSH WITH BOTTOM OF SEDIMENT PAD
2. HAND PACK GROWING MEDIUM AND #9 BASE UNDER AND AROUND THE SEDIMENT PAD TO A DISTANCE OF 0.3m
3. TOP OF SOIL/MULCH SHOULD BE AT MINIMUM 0.05 METERS BELOW THE WEIR WALL NOTCHES
4. ROUND RIVER ROCK MAY BE REPLACED WITH ALTERNATIVE EROSION CONTROL MEASURES
5. ALL MATERIAL AND WORKMANSHIP FOR CURB CUTS SHALL CONFORM TO CITY OF VANCOUVER STANDARD SPECIFICATIONS AND GUIDELINES
6. IF CURB CUT CANNOT BE INSTALLED AT CURB CONTROL JOINTS, BOND NEW CURB AND GUTTER TO EXISTING CURB AND GUTTER WITH EPOXY AND DOWEL CONNECTION.

REV.	REVISION DATE	APPROVED

INLETS AND OUTLETS
PRETREATMENT SEDIMENT BASIN

ISSUE DATE: FEBRUARY 2026

APPROVED BY: N. MEAD-FOX

GI GENERAL COMPONENTS DESIGN NOTES AND GUIDANCE

PURPOSE:

THE FOLLOWING COMPONENTS MAY BE USED IN A VARIETY OF GI SYSTEMS. THESE COMPONENTS SHOW PHYSICAL INFRASTRUCTURE COMPONENTS THAT MAY HAVE FIXED OR VARIED DIMENSIONS.

DESIGNER NOTES & GUIDELINES:

1. ALL DIMENSIONS ARE IN METERS UNLESS OTHERWISE NOTED.
2. THE DESIGNER MUST ADAPT COMPONENT DIMENSIONS TO ADDRESS SITE-SPECIFIC CONDITIONS. DETAILS REQUIRING CUSTOM DIMENSIONS SHOULD BE SHOWN ON CONSTRUCTION DRAWINGS. UNADJUSTED COMPONENTS MAY BE REFERENCED.
3. THE COMPONENTS REQUIRED AND RECOMMENDED FOR SPECIFIC GI SYSTEMS ARE REFERENCED ON THE SYSTEM TEMPLATES SHOWN IN GI STANDARD DRAWING SECTION 4, SECTION 5, AND SECTION 6.
4. THE DESIGNER MUST EVALUATE UTILITY SURVEYS FOR POTENTIAL UTILITY CROSSINGS OR CONFLICTS.
5. MINIMUM UTILITY SETBACKS AND PROTECTION MEASURES MUST CONFORM TO CURRENT CITY OF VANCOUVER ASSET PROTECTION STANDARDS AND OTHER UTILITY PROVIDER REQUIREMENTS.
6. BIORETENTION VEGETATION MUST BE SPECIFIED BY DESIGN PROFESSIONAL PER CoV GREEN INFRASTRUCTURE VEGETATION GUIDANCE

LAYOUT REQUIREMENTS:

1. REFER TO THE CITY OF VANCOUVER ACCESSIBILITY STRATEGY, STANDARD DRAWINGS AND CONSTRUCTION SPECIFICATIONS FOR RIGHT-OF-WAY, PARKING SPACE, AND ACCESSIBLE PATH REQUIREMENTS.
2. LOCATE CURB CUTS AND GUTTER MODIFICATIONS TO AVOID CONFLICTS WITH ACCESSIBILITY REQUIREMENTS (E.G., LOCATE OUTSIDE OF CROSSWALKS).
3. REFER TO THE DESIGN MANUAL FOR GUIDANCE ON PLACING CONCRETE CHECK DAMS

DESIGNER CHECKLIST (MUST SPECIFY, AS APPLICABLE):

- CONFIRM UTILITY PROTECTION MEASURES WITH GII STAFF
- CONFIRM MONITORING REQUIREMENTS WITH GII STAFF
- SELECT CURB EDGES AND BANDING ACCORDING TO GII STAFF INSTRUCTION
- CONFIRM PERFORATED PIPE LAYOUT AND PERFORATION REQUIREMENTS WITH GII STAFF
- CONFIRM ACCEPTABILITY OF ALL CATCHBASINS AND INSPECTION CHAMBERS WITH SEWER DEPARTMENT

GENERAL COMPONENT DRAWING DESCRIPTIONS

3.1.	PRECAST CONCRETE CATCHBASIN	PRECAST OFFSET CBS ARE A SHORTENED CATCHBASIN WITH A SMALL SUMP. PRECAST CBS SHOULD BE USED WHEN SDD S11.9 IS INFEASIBLE DUE TO PROJECT CONSTRAINTS. OFFSET CBS ARE TO BE USED WHEN DRAINAGE IS BEING DIRECTED TO ANOTHER FEATURE THAT CAN REPLICATE THE FUNCTION OF THE SUMP SUCH AS AN INSPECTION CHAMBER.
3.2.	MONITORING WELL	MONITORING WELLS ARE USED TO MEASURE THE SATURATION LEVEL OF SOIL IN A GREEN INFRASTRUCTURE SYSTEM. SATURATION LEVEL IS A GOOD INDICATOR OF HOW WELL A GREEN INFRASTRUCTURE SYSTEM IS DRAINING. THIS DRAWING PROVIDES MULTIPLE MONITORING WELLS FOR DIFFERENT SURFACE TREATMENTS.
3.3.	INSPECTION CHAMBER	INSPECTION CHAMBERS ARE USED TO MONITOR DRAINAGE IN LARGER GREEN INFRASTRUCTURE SYSTEMS. THEY CONNECT UNDERDRAINS SUCH AS THOSE IN GI3.7. TO CATCHBASINS AND SEWER LEADS.
3.4.	GI CLEANOUT	CLEANOUTS ARE INSTALLED AT THE "UPSTREAM" END OF PERFORATED PIPES. THEY ARE INSTALLED TO MAKE IT EASIER TO FLUSH UNDERDRAINS AND CLEAR PERFORATIONS.
3.5.	TREE TRENCH CURB EDGES	THESE CURB EDGES ARE DESIGNED TO CONFINE OPEN TREE PIT AREAS. THEY ARE TO BE PLACED PERPENDICULAR TO STREET CURBS AND SIDEWALKS.
3.6.	GI BANDING	GI BANDING IS DESIGNED TO CONFINE GREEN INFRASTRUCTURE ASSETS AND CONTAIN PONDED WATER. BANDING IS USED ALONG THE EDGES OF A GREEN INFRASTRUCTURE SYSTEM THAT ARE NOT ADJACENT TO A ROADWAY. PREFERRED BANDING OPTIONS DEPEND ON THE DEPTH OF PONDING AND THE ADJACENT SURFACE TREATMENT.
3.7.	UNDERDRAIN AND DISTRIBUTION PIPES	PERFORATED PIPES MAY BE USED AS UNDERDRAINS TO SLOWLY REMOVE WATER FROM A GREEN INFRASTRUCTURE ASSET, OR AS DISTRIBUTION PIPES, WHICH CAN CONVEY WATER INTO A GREEN INFRASTRUCTURE ASSET. PERFORATED PIPE DESIGN DEPENDS ON THE DESIRED RATE OF FLOW THROUGH THE PIPE AND THE EXPECTED INFILTRATION RATE OF THE SYSTEM.
3.8.	PVC CATCHBASIN	A PVC CATCHBASIN IS USED TO CAPTURE OVERFLOW FROM A GI SYSTEM AN DIRECT IT INTO THE SEWER SYSTEM. PVC CATCHBASINS MAY ONLY BE USED WHEN SURROUNDED BY GROWING MEDIUM. THEY ARE A MORE AFFORDABLE ALTERNATIVE TO TRADITIONAL CATCHBASINS AND THE OVERLYING DOMED INLET GRATE HELPS PREVENT CLOGGING FROM SEDIMENT AND DEBRIS.

REV.	REVISION DATE	APPROVED

**GENERAL COMPONENTS
GI COMPONENTS DESIGN GUIDANCE**

ISSUE DATE: FEBRUARY 2026
APPROVED BY: N. MEAD-FOX

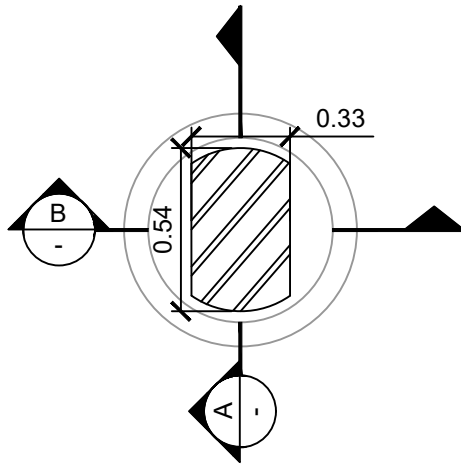

PLAN VIEW

TR 23/24 'CURB STYLE'
FRAME & GRATE
SET ON 'CURB STYLE'
CONCRETE
LID, REINFORCED TO MEET
HS-20 LIVE LOADING

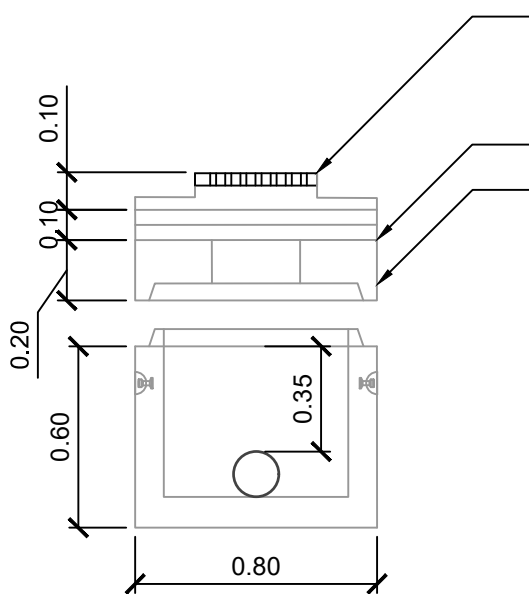

SECTION B

COV GRATE No. 31 & FRAME
No. 30. CEMENT FRAME IN
PLACE AFTER ALIGNING

50mm RISERS. MIN 1, MAX 3

CATCHBASIN LID

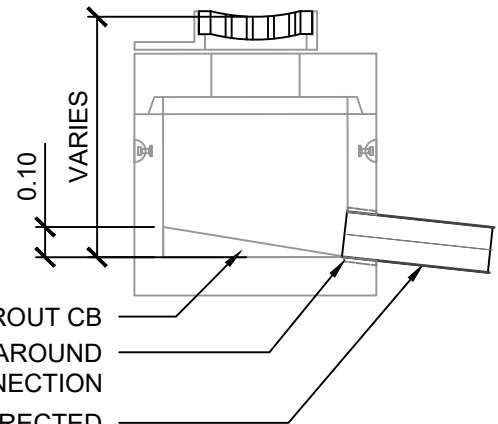

SECTION A

GROUT CB
GROUT SEALING AROUND
PIPE CONNECTION
CB LEAD MIN 1% DIRECTED
TO MANHOLE, CATCHBASIN,
OR STORM SEWER

NOTES:

1. WHEN SUMP IS INSTALLED ROADSIDE TO CATCHBASIN, CONNECTION PIPE FROM CB TO SUMP SHALL BE DUCTILE IRON OR CONCRETE ENCASED.
2. USE 750mm BARREL AT ALL SAG POINTS.
3. EXPANSION JOINT REQUIRED IN CURB AND GUTTER AT MIDDLE OF CB FRAME FOR 600mm BARREL INSTALLATIONS OR 1m EACH SIDE OF FRAME FOR 750mm BARREL INSTALLATIONS.
4. GROUT TO SEAL PIPE OPENING, LIFTING HOLES, TEMPORARY DRAIN HOLE(S), SECTIONS, AND SPACER RINGS, INSIDE AND OUT.

REV.	REVISION DATE	APPROVED

GENERAL COMPONENTS
GI OFFSET CATCHBASIN

ISSUE DATE: FEBRUARY 2026
APPROVED BY: N. MEAD-FOX

3.2A: MONITORING WELL WITH CLEAR CRUSHED AGGREGATE UNDER PERMEABLE PAVEMENT

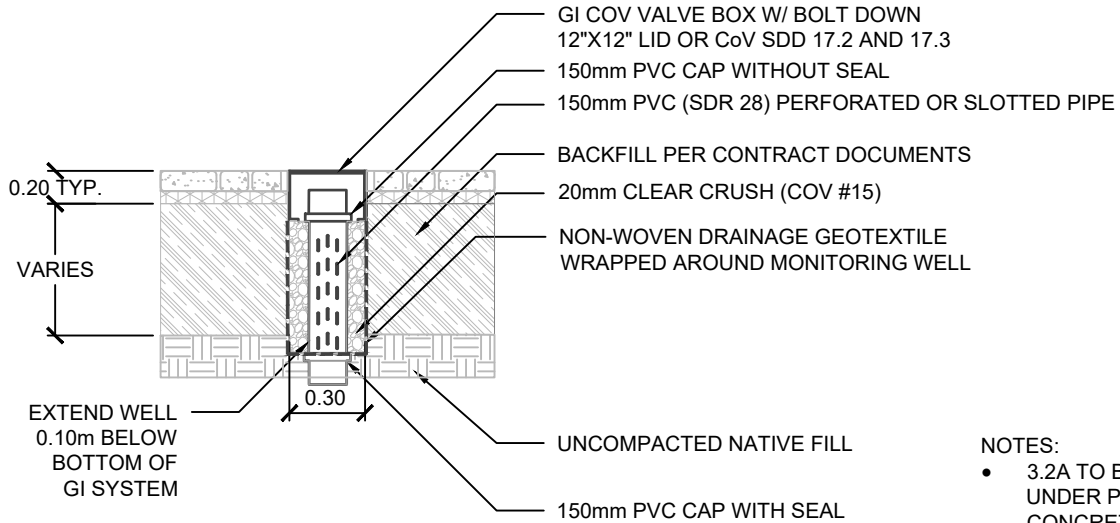

- NOTES:
- 3.2A TO BE USED FOR GI UNDER PAVEMENT OR CONCRETE

3.2B: MONITORING WELL WITH PERFORATED DRAINAGE BOARD UNDER PAVEMENT

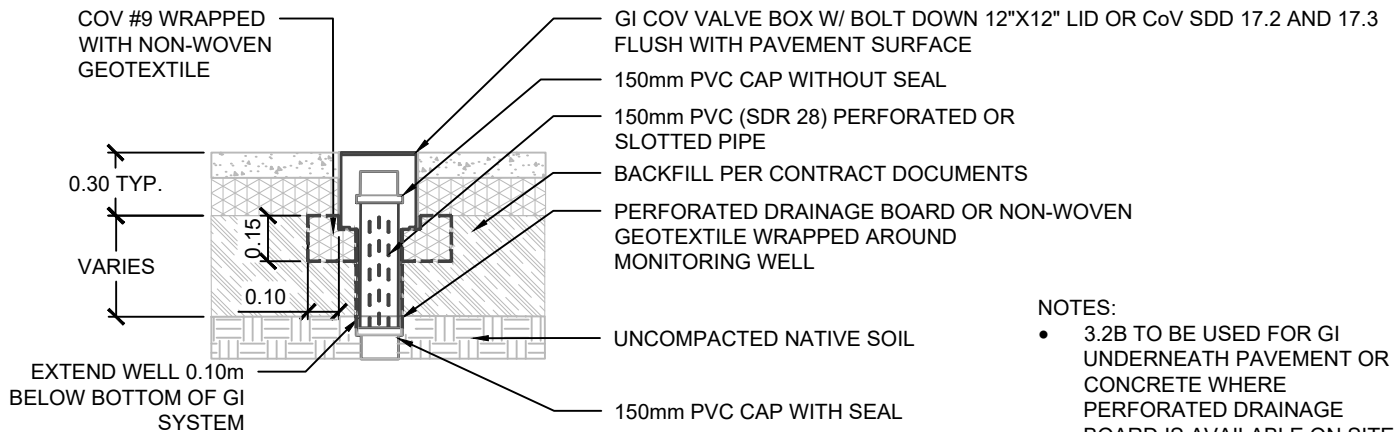

- NOTES:
- 3.2B TO BE USED FOR GI UNDERNEATH PAVEMENT OR CONCRETE WHERE PERFORATED DRAINAGE BOARD IS AVAILABLE ON SITE

3.2C: MONITORING WELL IN SOIL

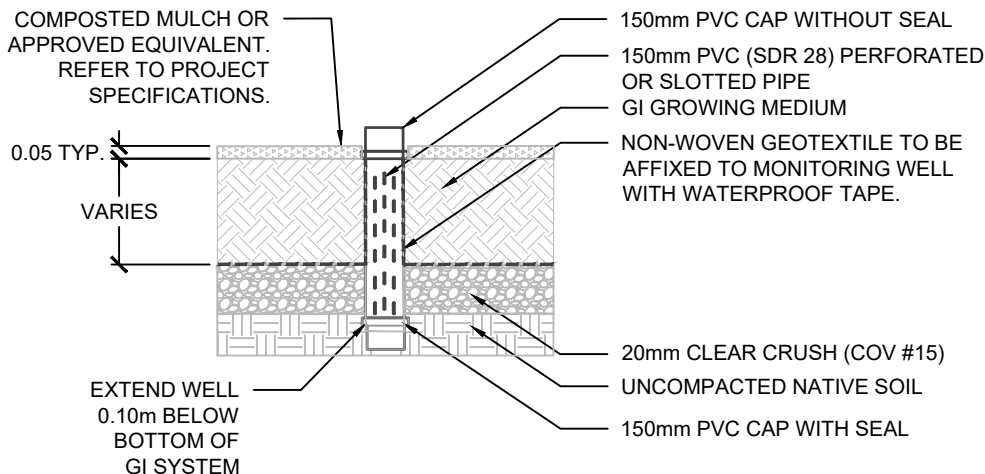

- NOTES:
- 3.2C TO BE USED IN GI WITH EXPOSED VEGETATION

REV.	REVISION DATE	APPROVED

**GENERAL COMPONENTS
MONITORING WELL**

ISSUE DATE: FEBRUARY 2026
APPROVED BY: N. MEAD-FOX

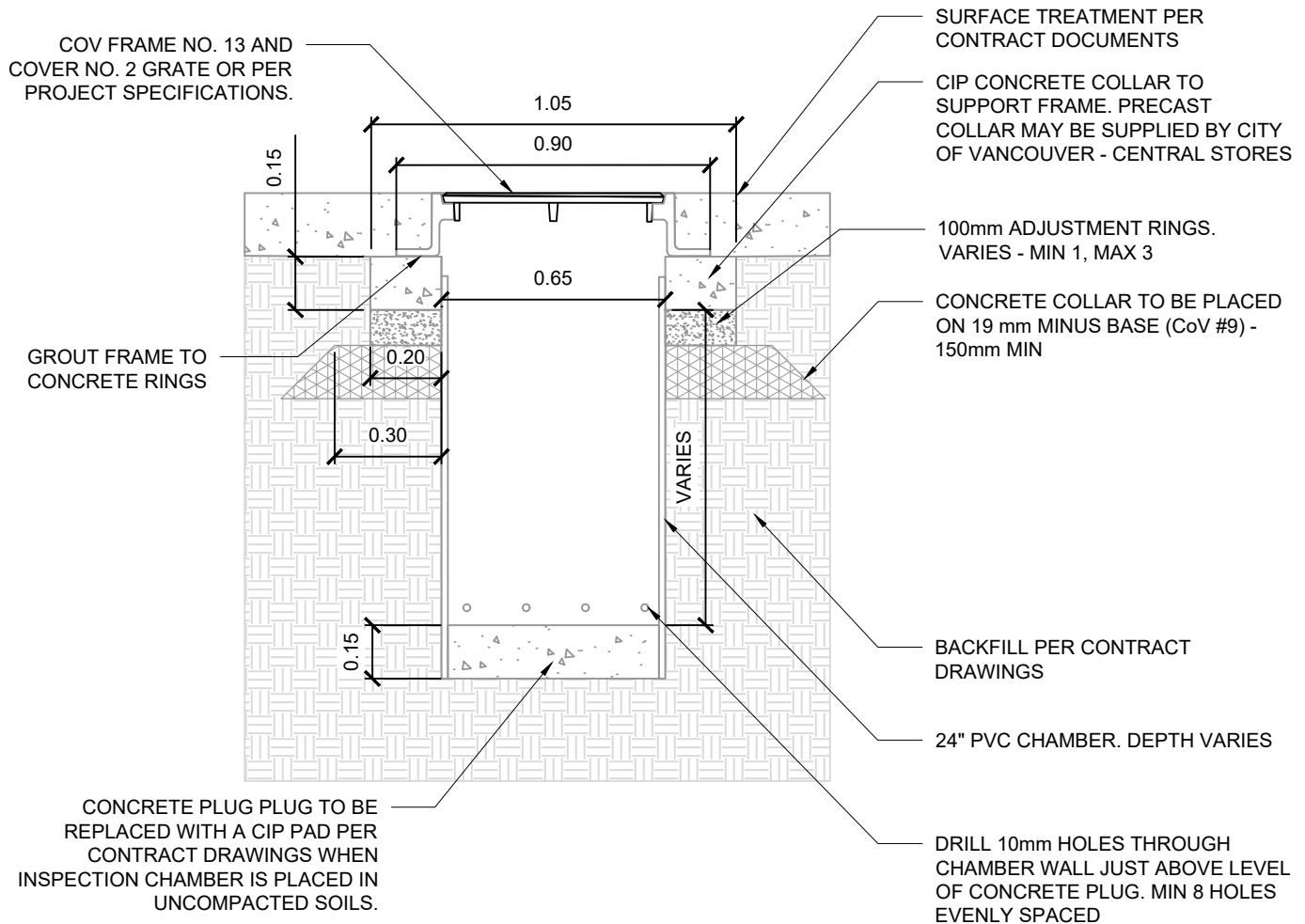

NOTES:

1. GI INSPECTION CHAMBERS IN THE ROADWAY OR IN PAVED BOULEVARDS MUST BE DESIGNED FOR H20 LOADING PLUS 25%.
2. A 6.0m VERTICAL CLEARANCE IS PREFERRED OVER ALL INSPECTION CHAMBERS.
3. GI INSPECTION CHAMBERS SHOULD BE PLACED AT THE LOW POINT OF THE CONNECTED GI SYSTEM.
4. INSPECTION CHAMBERS CONNECTED BY DISTRIBUTION PIPES SHOULD HAVE A MAXIMUM SEPARATION DISTANCE OF 40 METERS

REV.	REVISION DATE	APPROVED

**GENERAL COMPONENTS
INSPECTION CHAMBER**

ISSUE DATE: FEBRUARY 2026
APPROVED BY: N. MEAD-FOX

3.4A CLEANOUT IN PAVEMENT

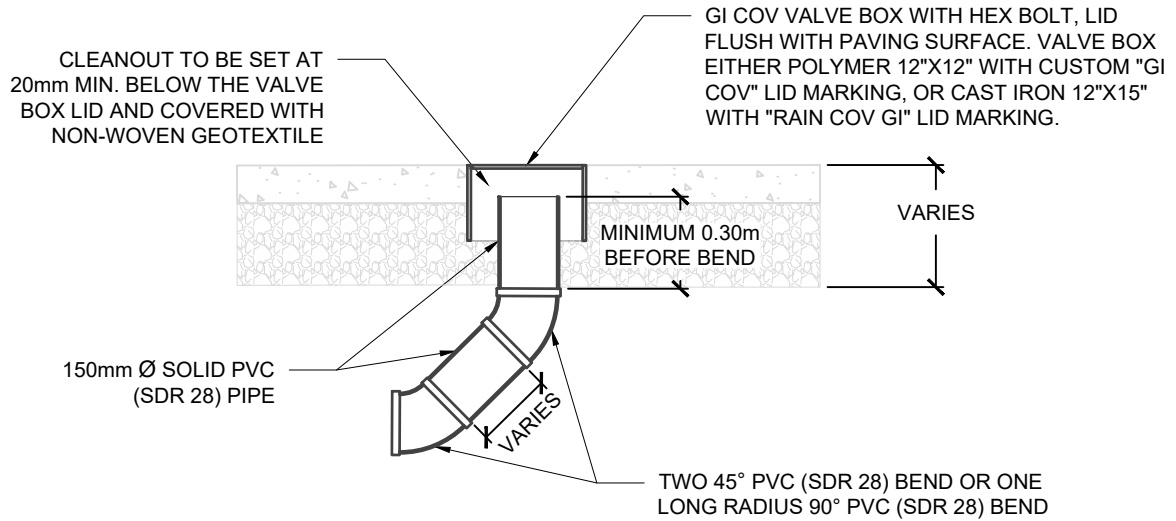

3.4B CLEANOUT IN SOIL

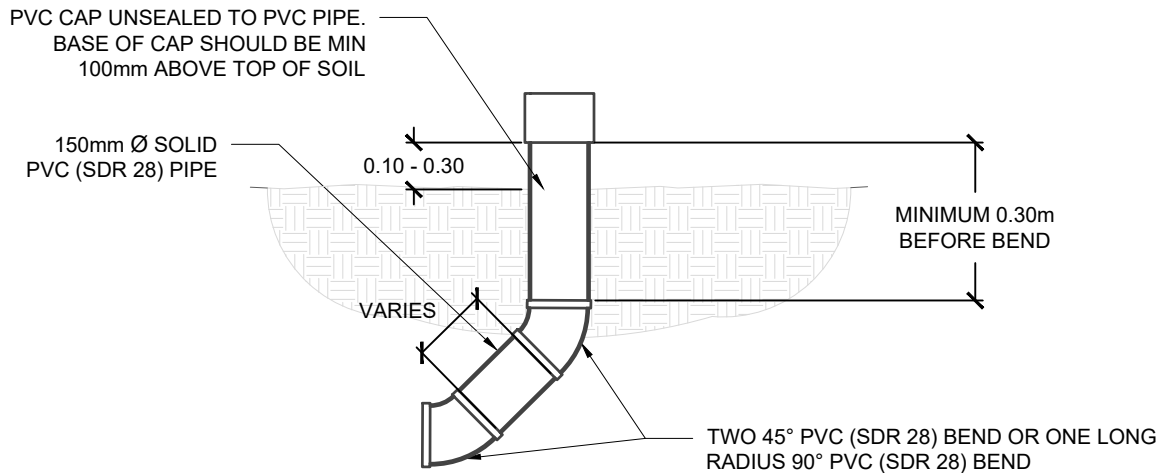

NOTES:

1. GI CLEANOUTS IN THE ROADWAY OR IN PAVED BOULEVARDS (GI3.4A) MUST BE DESIGNED FOR H₂O LOADING PLUS 25%. REFER TO S17.2 FOR VALVE BOX STRUCTURAL DETAILS
2. GI CLEANOUTS IN SOIL AREAS (GI3.4B) SHOULD MAY BE TOPPED WITH A PVC CAP OR A DOME GRATE. BOTH MUST NOT BE SEALED TO THE CONNECTED PVC PIPE TO ALLOW FOR FUTURE REMOVAL AND MAINTENANCE.
3. GI CLEANOUTS SHOULD BE PLACED AT THE HIGH POINT OF THE CONNECTED GI SYSTEM.
4. PIPES CONNECTING CLEANOUTS TO INSPECTION CHAMBERS OR CATCH BASINS SHOULD HAVE A MAXIMUM SEPARATION DISTANCE OF 40 METERS.

REV.	REVISION DATE	APPROVED

GENERAL COMPONENTS
GI CLEANOUT

ISSUE DATE: FEBRUARY 2026
APPROVED BY: N. MEAD-FOX

3.5A. L-SHAPE UNDER PAVERS

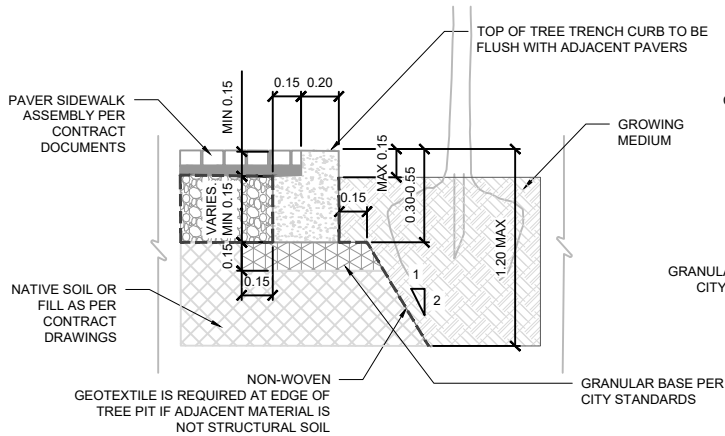

3.5B. L-SHAPE UNDER CIP SIDEWALK

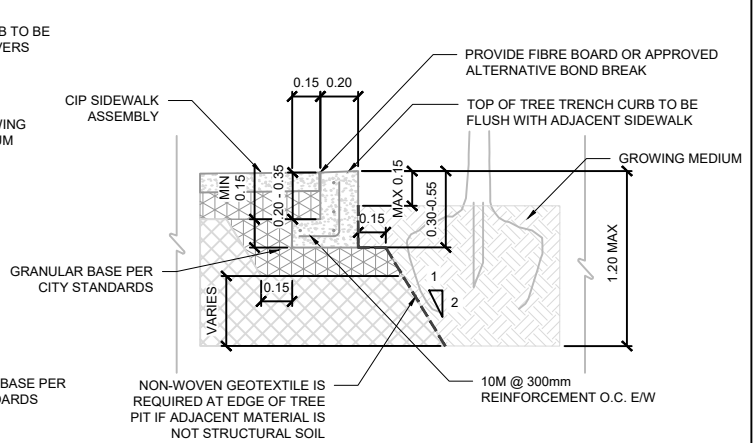

3.5C. THICKENED CONCRETE EDGE

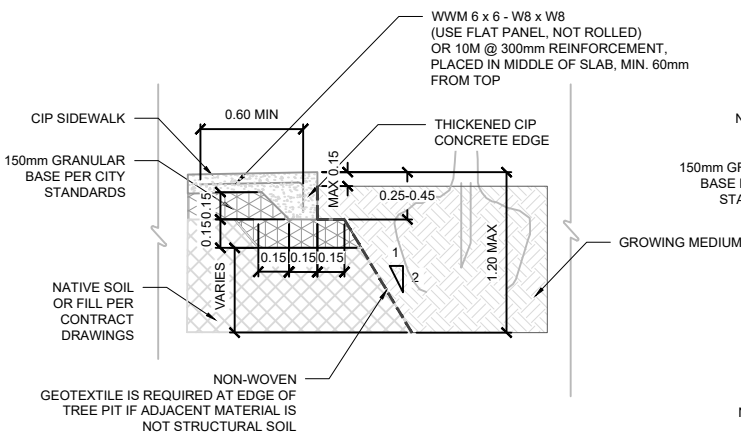

3.5D. RECTANGULAR BANDING

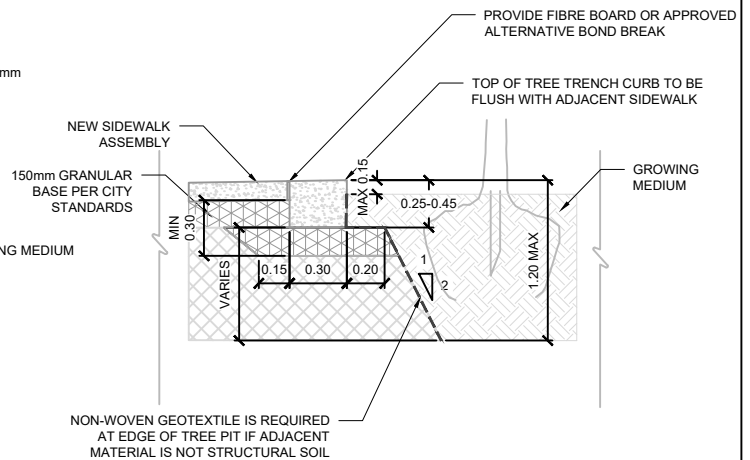

SOIL EXCAVATION, COMPACTION AND BACKFILLING

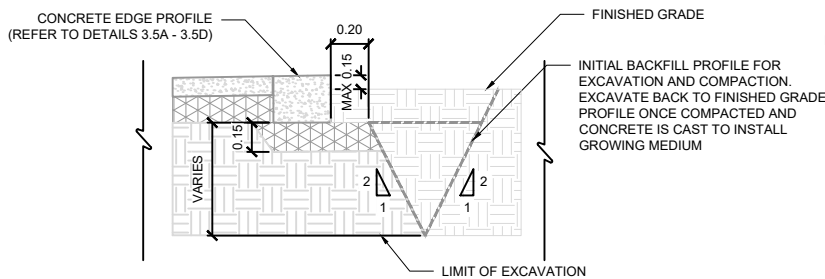

CONTEXTUAL PLAN VIEW

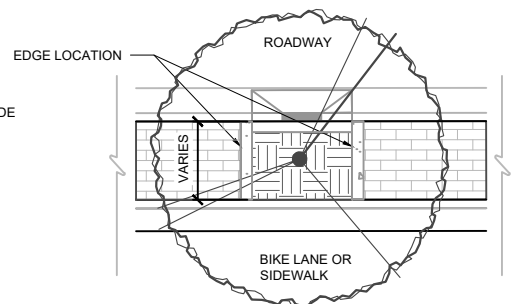

NOTES:

1. GROWING MEDIUM THAT IS NOT ADJACENT TO STRUCTURAL SOIL MUST BE WRAPPED WITH NON-WOVEN GEOTEXTILE ON ALL SIDES
2. TYPE A TO BE USED IF ADJACENT SIDEWALK IS BEING CONSTRUCTED WITH PERMEABLE PAVERS. GROWING MEDIUM MAY BE UP TO 550mm BELOW TOP OF THE ADJACENT SIDEWALK.
3. TYPE B TO BE USED IF ADJACENT SIDEWALK IS A STANDARD CIP SIDEWALK.
4. TYPE C TO BE USED IF ADJACENT SIDEWALK IS BEING CONSTRUCTED AND GROWING MEDIUM IS WITHIN 50mm OF THE TOP OF THE ADJACENT SIDEWALK (NO PONDING DEPTH IS REQUIRED).
5. TYPE D TO BE USED WITH EXISTING SIDEWALK AND GROWING MEDIUM IS WITHIN 50mm OF THE TOP OF THE BANDING (NO PONDING DEPTH IS REQUIRED).
6. DESIGN CRITERIA, APPLIED LOADING CONSTRAINTS, AND MAXIMUM VERTICAL POINT LOADING FOR VARIOUS COVER WIDTHS MAY BE PROVIDED UPON REQUEST.
7. INSTALL EMBEDDED REINFORCEMENT AND CONCRETE IN CONFORMANCE WITH CITY OF VANCOUVER CONSTRUCTION SPECIFICATIONS.
8. STRUCTURAL MEMBER SIZING AND ORIENTATION OF ELEMENT TO BE CONFIRMED BY THE PROJECT ENGINEER. REINFORCEMENT TO BE INSTALLED AS OUTLINED IN THIS DRAWING, UNLESS OTHERWISE NOTED BY THE ENGINEER.
9. NOTIFY THE ENGINEER IF EXISTING SITE CONDITIONS DIFFER FROM THOSE SHOWN IN THIS DETAIL.
10. REINFORCEMENT IS NOT REQUIRED FOR 3.5B IF VERTICAL PORTION OF BANDING WALL IS LESS THAN 200mm ABOVE TOE

REV.	REVISION DATE	APPROVED

GENERAL COMPONENTS
TREE TRENCH CURB EDGES

ISSUE DATE: FEBRUARY 2026
APPROVED BY: N. MEAD-FOX

3.6A: PREFERRED

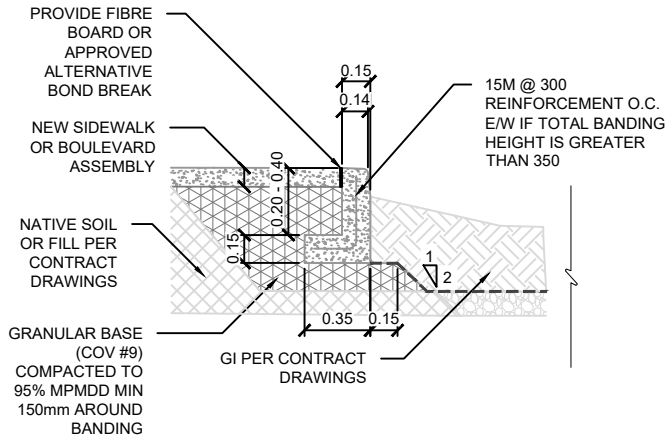

3.6B: ALTERNATE

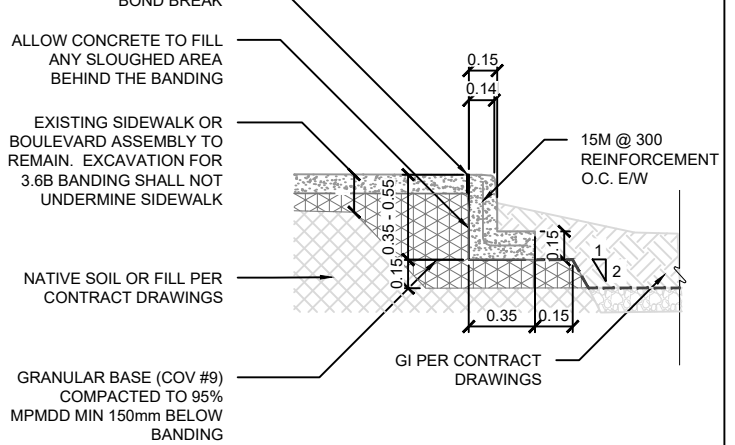

SOIL EXCAVATION, COMPACTION AND BACKFILLING

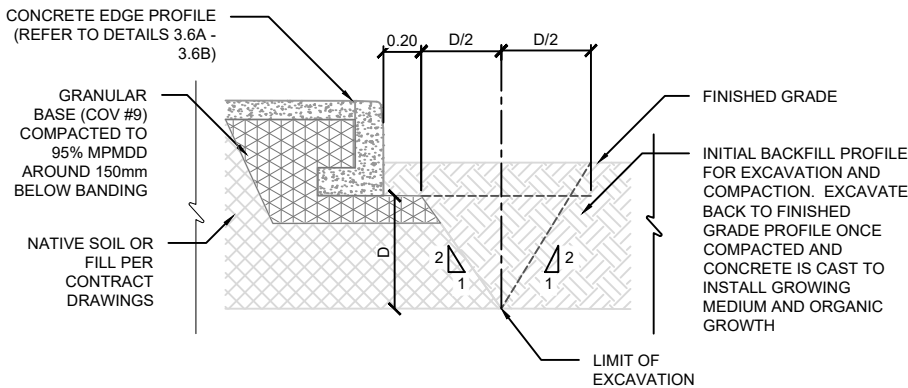

PLAN VIEW FOR CONTEXT

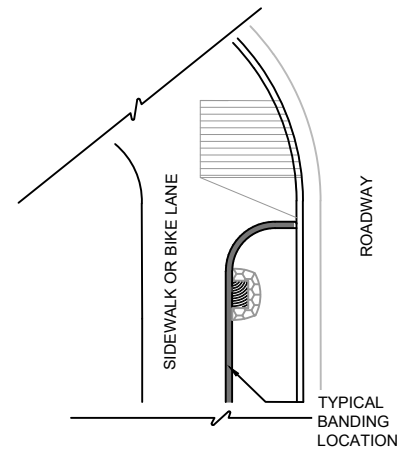

NOTES:

1. GI BANDING SHALL NOT BE USED AS A CURB OR IMMEDIATELY ADJACENT TO A ROADWAY.
2. TYPE A TO BE USED IF ADJACENT SIDEWALK, BIKE LANE, OR BOULEVARD IS BEING RECONSTRUCTED.
3. TYPE B TO BE USED IF ADJACENT SIDEWALK, BIKE LANE, OR BOULEVARD WILL REMAIN.
4. DESIGN CRITERIA, APPLIED LOADING CONSTRAINTS, AND MAXIMUM VERTICAL POINT LOADING FOR VARIOUS COVER WIDTHS MAY BE PROVIDED UPON REQUEST.
5. IF THE ADJACENT SURFACE IS NOT A SIDEWALK (I.E. A RETAINED BOULEVARD) TYPE A AND TYPE B CURBS MAY BE RAISED UP TO 150mm ABOVE THE ADJACENT SURFACE ELEVATION IF REQUIRED BY GRADING CONDITIONS.
6. THE MAXIMUM BANDING HEIGHT SHALL BE 550mm.
7. INSTALL EMBEDDED REINFORCEMENT AND CONCRETE IN CONFORMANCE WITH CITY OF VANCOUVER CONSTRUCTION SPECIFICATIONS.
8. STRUCTURAL MEMBER SIZING AND ORIENTATION OF ELEMENT TO BE CONFIRMED BY THE ENGINEER. REINFORCEMENT TO BE INSTALLED AS OUTLINED IN THIS DRAWING, UNLESS OTHERWISE NOTED BY THE ENGINEER.
9. NOTIFY THE ENGINEER IF EXISTING SITE CONDITIONS DIFFER FROM THOSE SHOWN IN THIS DETAIL.
10. REINFORCEMENT IS NOT REQUIRED IF THE TOTAL HEIGHT OF THE BANDING WALL IS LESS THAN 350mm (NOTE REINFORCEMENT WILL ALWAYS BE REQUIRED WHEN THE TOP OF BANDING GRADE IS ABOVE THE ADJACENT PAVED SURFACE).

REV.	REVISION DATE	APPROVED

GENERAL COMPONENTS
GI BANDING

ISSUE DATE: FEBRUARY 2026
APPROVED BY: N. MEAD-FOX

3.7A NON-INFILTRATION
GI UNDERDRAIN

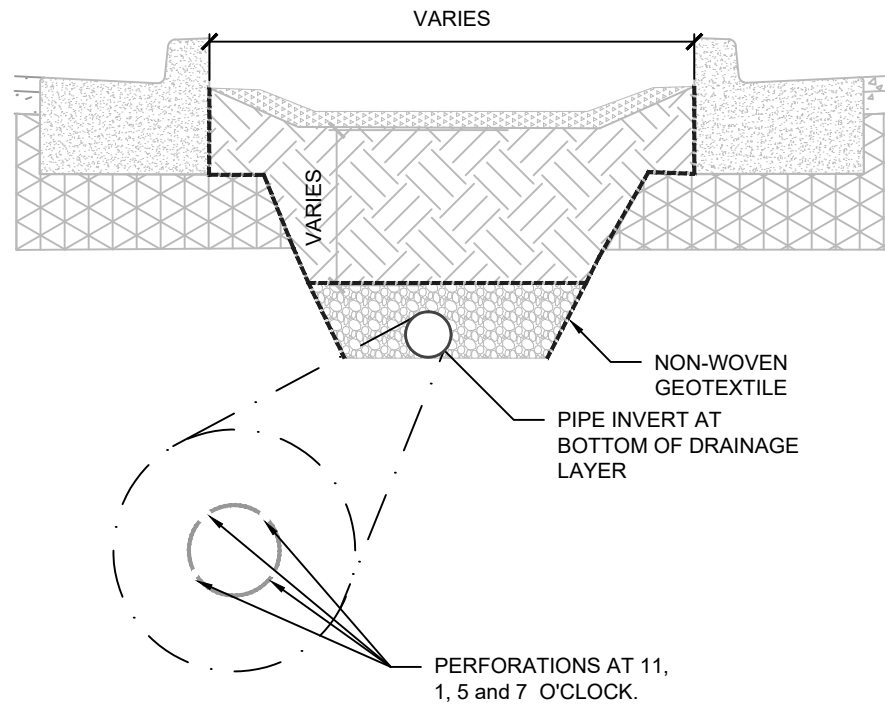

3.7B PARTIALLY INFILTRATING
GI UNDERDRAIN

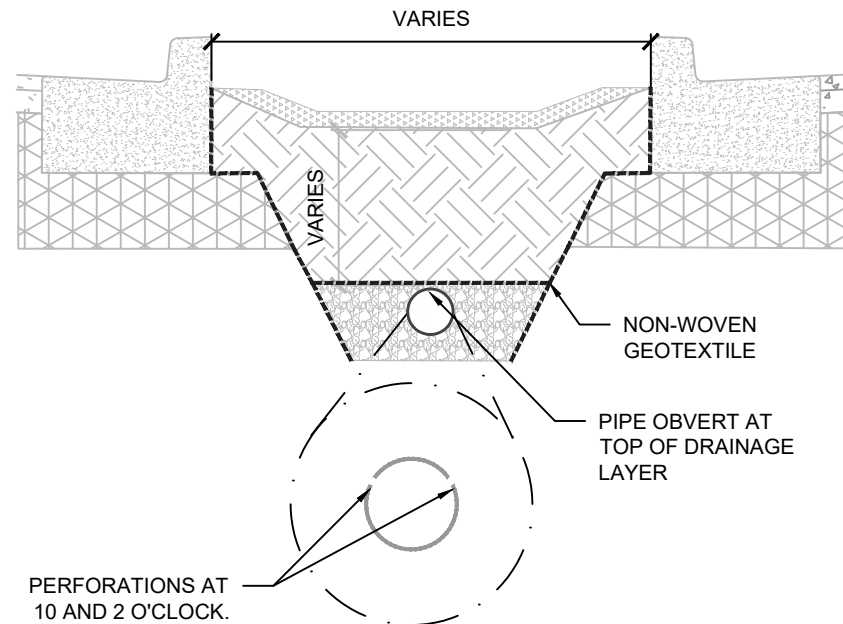

3.7C FLAT (PREFERRED) OR SLOPED
DISTRIBUTION PIPE

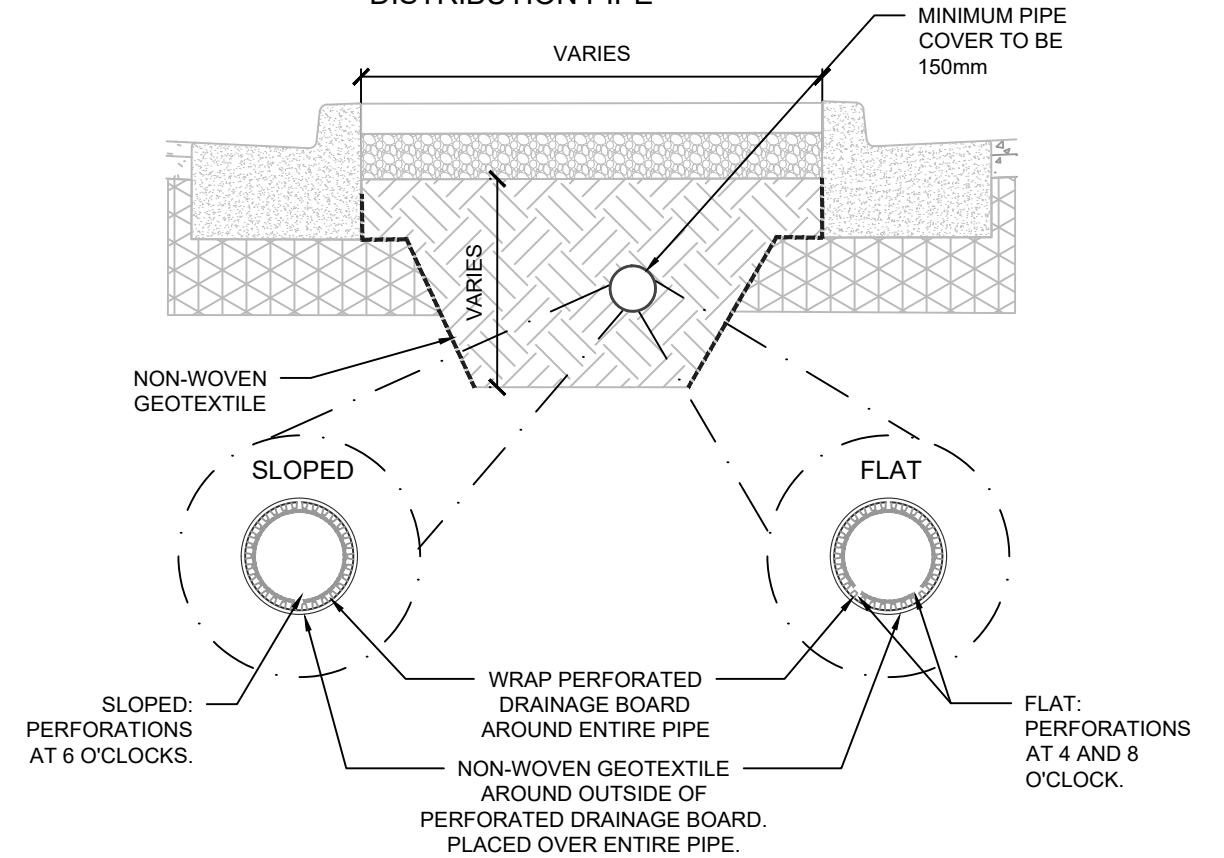

3.7D FLAT DISTRIBUTION PIPE IN
BIORETENTION SOIL

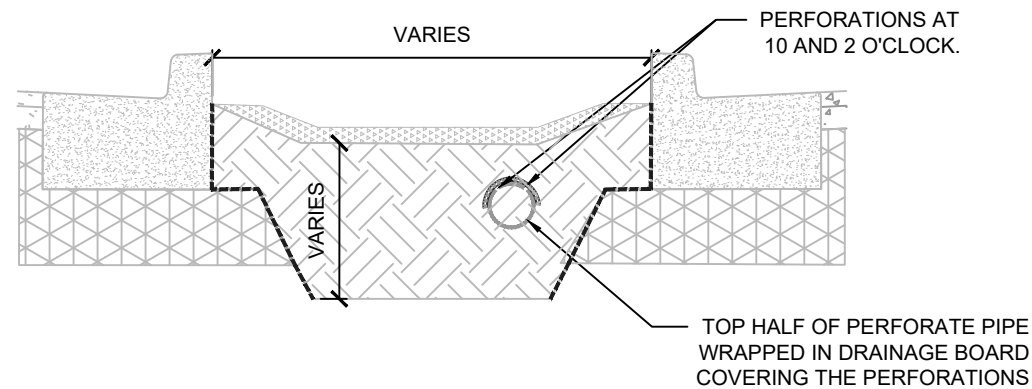

3.7E FLAT DISTRIBUTION PIPE IN
ENGINEERED SOIL

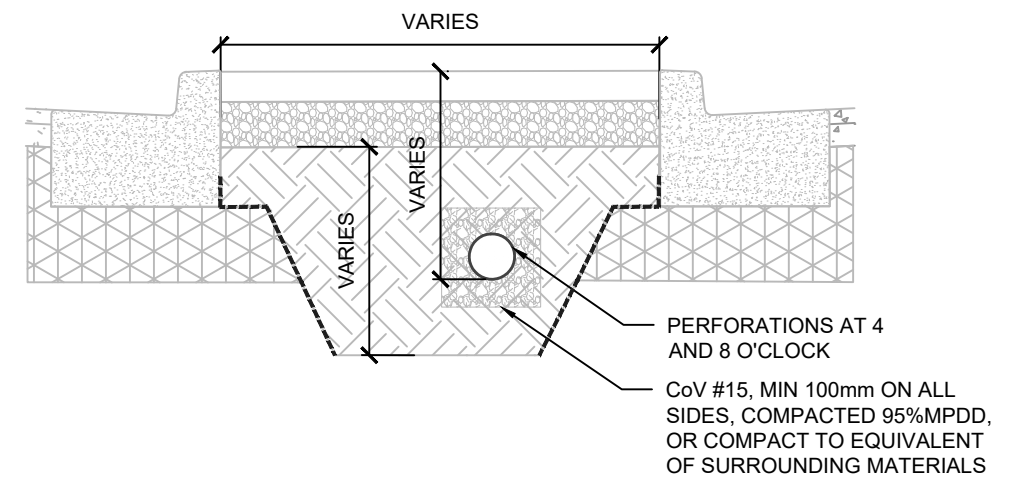

NOTE: SLOPED DISTRIBUTION PIPES MAY ONLY BE USED ON PIPE RUNS GREATER THAN 10.0m. MAX SLOPE OF 5%..

NOTES:

- 3.7A TO BE USED IF GI ASSET IS NON-INFILTRATING (i.e. FILTRATION ONLY). TYPICALLY USED IN BIORETENTION SYSTEMS.
- 3.7B TO BE USED IF GI ASSET CAN INFILTRATE BUT REQUIRES AN UNDERDRAIN FOR SOIL DRAINAGE. TYPICALLY USED IN BIORETENTION SYSTEMS.
- IF THE PERFORATED PIPE IS TO BE USED AS AN UNDERDRAIN TO CONVEY WATER OUT OF THE GI SYSTEM, THE INVERT OF THE PIPE SHOULD BE PLACED ABOVE THE INVERT OF THE SEWER CONNECTION.
- 3.7C, 3.7D, AND 3.7E TO BE USED TO DISTRIBUTE RAINWATER IN INFILTRATION TRENCHES AND RAINWATER TREE TRENCHES.
- IF THE PERFORATED PIPE IS TO BE USED AS A DISTRIBUTION PIPE TO CONVEY WATER INTO THE GI SYSTEM, THE INVERT SHOULD BE PLACED BELOW THE INVERT OF THE SEWER CONNECTION.
- SLOPED DISTRIBUTION PIPES MAY ONLY BE USED ON PIPE RUNS GREATER THAN 10.0m. MAX SLOPE OF 5%..
- ALL DISTRIBUTION PIPES TO BE LAID AT 0%
- UNDERDRAIN PIPES MAY BE LAID ON A SLOPE THAT MATCHES THE UNDERLYING SUB-BASE AS SHOWN IN 3.7C
- REFER TO DESIGN MANUAL FOR FURTHER DETAILS REGARDING PERFORATED PIPE DESIGN AND PLACEMENT

GENERAL COMPONENTS
UNDERDRAINS AND DISTRIBUTION PIPES

ISSUE DATE: FEBRUARY 2024

APPROVED BY: N. MEAD-FOX

1	05/15/2025	NICK MEAD-FOX
REV.	REVISION DATE	APPROVED

PLAN VIEW

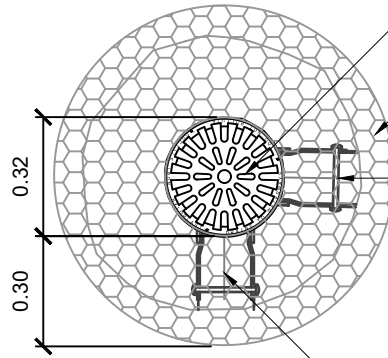

DRAIN BASIN WITH DOME GRATE OR APPROVED EQUIVALENT

90-120mm ROUND RIVER ROCK STONE OR WOOD DEBRIS FILLED COMPOST SOCK

INSERT-A-TEE OR APPROVED EQUIVALENT CONNECTED TO GI PERFORATED PIPE. ANGLE BETWEEN SEWER CONNECTION PIPE AND PERFORATED PIPE VARIES PER CONTRACT DRAWINGS.

150mm PVC SOLID PIPE TO EXISTING CB. REFER TO SEWER STANDARDS FOR MORE INFORMATION.

SECTION VIEW

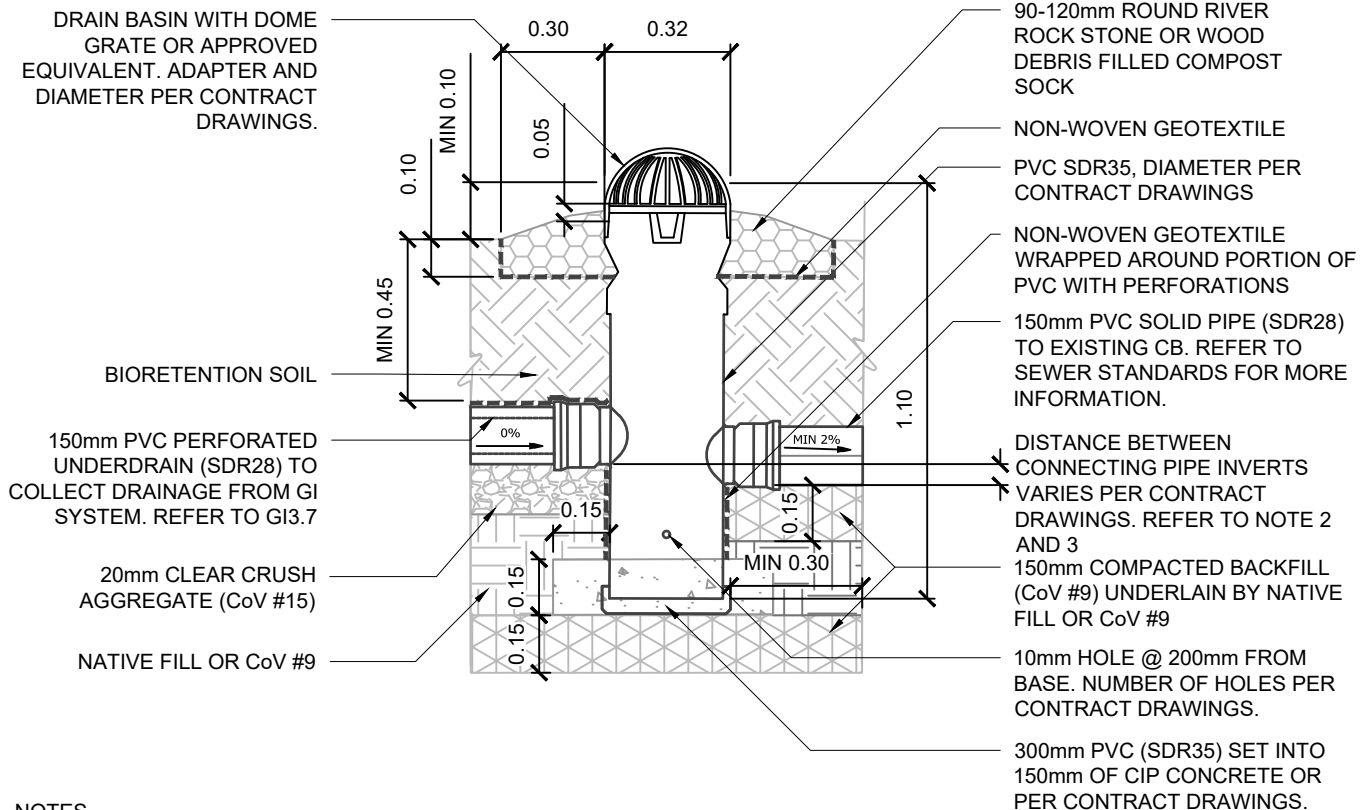

DRAIN BASIN WITH DOME GRATE OR APPROVED EQUIVALENT. ADAPTER AND DIAMETER PER CONTRACT DRAWINGS.

90-120mm ROUND RIVER ROCK STONE OR WOOD DEBRIS FILLED COMPOST SOCK

NON-WOVEN GEOTEXTILE

PVC SDR35, DIAMETER PER CONTRACT DRAWINGS

NON-WOVEN GEOTEXTILE WRAPPED AROUND PORTION OF PVC WITH PERFORATIONS

150mm PVC SOLID PIPE (SDR28) TO EXISTING CB. REFER TO SEWER STANDARDS FOR MORE INFORMATION.

DISTANCE BETWEEN CONNECTING PIPE INVERTS VARIES PER CONTRACT DRAWINGS. REFER TO NOTE 2 AND 3

150mm COMPACTED BACKFILL (CoV #9) UNDERLAIN BY NATIVE FILL OR CoV #9

10mm HOLE @ 200mm FROM BASE. NUMBER OF HOLES PER CONTRACT DRAWINGS.

300mm PVC (SDR35) SET INTO 150mm OF CIP CONCRETE OR PER CONTRACT DRAWINGS.

BIORETENTION SOIL

150mm PVC PERFORATED UNDERDRAIN (SDR28) TO COLLECT DRAINAGE FROM GI SYSTEM. REFER TO GI3.7

20mm CLEAR CRUSH AGGREGATE (CoV #15)

NATIVE FILL OR CoV #9

NOTES

1. THIS CB MAY NOT BE USED IN LIEU OF A SEWERS STANDARD CB OR TO INCREASE THE MAXIMUM CONTRIBUTING DRAINAGE AREA TO A SEWERS CB
2. IF THE PERFORATED PIPE IS TO BE USED AS A DISTRIBUTION PIPE TO CONVEY WATER INTO THE GI SYSTEM, THE INVERT SHOULD BE PLACED BELOW THE INVERT OF THE SEWER CONNECTION.
3. USE OF THIS PVC CB IS DEPENDENT ON APPROVAL FROM CITY OF VANCOUVER SEWERS AND DRAINAGE DESIGN AND GREEN INFRASTRUCTURE IMPLEMENTATION BRANCHES
4. DRAIN BASIN WITH DOME GRATE AND PVC. DIAMETER PER CONSTRUCTION DRAWINGS

REV.	REVISION DATE	APPROVED

GENERAL COMPONENTS
PVC CATCHBASIN

ISSUE DATE: FEBRUARY 2026

APPROVED BY: N. MEAD-FOX

BIORETENTION DESIGN NOTES AND GUIDANCE

PURPOSE:

BIORETENTION SYSTEMS RETAIN RAINWATER RUNOFF BY PROVIDING SURFACE, SUBSURFACE STORAGE AND INFILTRATION INTO NATIVE SOIL. WATER IS ALSO TREATED AS IT FILTERS THROUGH THE BIORETENTION SOIL.

THE FOLLOWING DRAWINGS ARE TEMPLATES FOR DESIGNING BIORETENTION SYSTEMS IN CITY OF VANCOUVER RIGHT-OF-WAYS. THE DRAWINGS CONTAIN THE COMPONENTS, MATERIALS, AND COMPOSITION REQUIRED FOR BEST PRACTICE BIORETENTION DESIGN. EACH DRAWING HAS VARIABLE DIMENSIONS WHICH MUST BE ADAPTED FOR SITE CONDITIONS AND SHOWN ON SITE DRAWINGS. IF A NUMERICAL DIMENSION IS PROVIDED, THE DIMENSION IS REQUIRED AT THE FIXED VALUE.

DESIGNER NOTES & GUIDELINES:

1. THE DESIGNER MUST ADAPT PLAN AND SECTION DRAWINGS TO ADDRESS SITE-SPECIFIC CONDITIONS.
2. BIORETENTION AREA, PONDING DEPTH, BIORETENTION SOIL DEPTH, AND AGGREGATE STORAGE DEPTH MUST BE SIZED TO MEET PROJECT HYDROLOGIC PERFORMANCE GOALS.
3. PONDING AND BIORETENTION SOIL DRAWDOWN TIME (I.E., TIME FOR MAXIMUM SURFACE PONDING TO DRAIN THROUGH THE BIORETENTION SOIL AFTER THE END OF A STORM) RECOMMENDATIONS:
 - 24 HOUR MAXIMUM SURFACE PONDING DRAWDOWN
 - 72 HOUR MAXIMUM DRAWDOWN FOR BIORETENTION SOIL AND AGGREGATE STORAGE
4. AN AGGREGATE COURSE IS REQUIRED UNDER THE BIORETENTION SOIL FOR ALL BIORETENTION SYSTEMS WHERE AN UNDERDRAIN IS REQUIRED TO MEET DRAWDOWN REQUIREMENTS.
5. TO ENCOURAGE INFILTRATION AND EVEN PONDING, THE FACILITY SUBGRADE AND BIORETENTION SOIL GRADE SHOULD BE FLAT. MID-CELL WEIR WALLS MAY BE USED TO TERRACE FACILITIES TO PROVIDE SUFFICIENT PONDING FOR INSTALLATIONS WITH HIGHER ADJACENT ROAD SLOPES. DESIGNER MUST SPECIFY WEIR WALL HEIGHT AND SPACING.
6. WHEN FACILITY CONSTRUCTION IMPACTS EXISTING SIDEWALK, ALL SAW CUTS MUST ADHERE TO CITY OF VANCOUVER REQUIREMENTS. SAW CUTS SHOULD BE ALONG SCORE LINES AND ANY DISTURBED SIDEWALK PANELS SHOULD BE REPLACED IN THEIR ENTIRETY.
7. GI FACILITIES IN PUBLIC RIGHT OF WAY SHALL BE DESIGNED WITH A SAFE, DESIGNATED OVERLAND FLOW PATH TO THE STREET IN THE EVENT THAT THE OVERFLOW STRUCTURE IS OBSTRUCTED OR CLOGGED. THIS FLOW PATH SHOULD BE REFLECTED IN SITE GRADING AND LABELED ON GI DRAWINGS.
8. THE DESIGNER MUST EVALUATE UTILITY SURVEYS FOR POTENTIAL UTILITY CROSSINGS OR CONFLICTS. MINIMUM UTILITY SETBACKS AND PROTECTION MEASURES MUST CONFORM TO CURRENT CITY OF VANCOUVER ASSET PROTECTION STANDARDS AND OTHER UTILITY PROVIDER REQUIREMENTS.
9. BIORETENTION VEGETATION MUST BE SPECIFIED BY A DESIGN PROFESSIONAL AND IN ACCORDANCE WITH THE CITY OF VANCOUVER GREEN INFRASTRUCTURE PLANTING GUIDELINES.

RELATED DETAILS		
EDGE TREATMENTS	GI 3.5	GI 3.6
INLETS	GI 2.1	GI 2.6
UNDERDRAINS:	GI 3.7	
CHECK DAMS:	GI 4.7	
MONITORING WELL	GI 3.2	
CLEANOUTS	GI 3.4	
WEIRS AND SEDIMENT PAD	GI 4.5	GI 4.6
INSPECTION CHAMBERS	GI 3.3	
CATCHBASINS	GI 3.1	GI 3.8

RELATED SPECIFICATIONS	COV SPEC NO.
- BIORETENTION SYSTEMS	***
- BIORETENTION SOIL MIX	***
- AGGREGATES AND GRANULAR MATERIALS	31 05 17
- GEOSYNTHETICS	31 32 19

***TEMPLATE ONLY. AVAILABLE UPON REQUEST FROM THE GII BRANCH.

LAYOUT REQUIREMENTS:

1. REFER TO THE CITY OF VANCOUVER ACCESSIBILITY STRATEGY, STANDARD DRAWINGS AND CONSTRUCTION SPECIFICATIONS FOR RIGHT-OF-WAY, PARKING SPACE, AND ACCESSIBLE PATH REQUIREMENTS.
2. LOCATE CURB CUTS AND GUTTER MODIFICATIONS TO AVOID CONFLICTS WITH ACCESSIBILITY REQUIREMENTS (E.G., LOCATE OUTSIDE OF CROSSWALKS).
3. IDENTIFY ALL SIGN AND POST LOCATIONS WITHIN THE GI AREA AND ENSURE PROPER BACKFILL MATERIALS ARE PRESENT TO PROVIDE THE NECESSARY STRUCTURAL SUPPORT FOR ALL SIGN BASES.

DESIGNER CHECKLIST (MUST SPECIFY, AS APPLICABLE):

- BIORETENTION WIDTH AND LENGTH
- DEPTH OF PONDING
- DEPTH OF FREEBOARD
- DEPTH OF BIORETENTION SOIL
- DEPTH AND TYPE OF AGGREGATE STORAGE, IF ANY
- SURFACE ELEVATION (TOP OF BIORETENTION SOIL) AT UPSLOPE AND DOWNSLOPE ENDS OF FACILITY
- CONTROL POINTS AT EVERY PLANTER WALL CORNER AND POINT OF TANGENCY
- DIMENSIONS AND DISTANCE TO EVERY INLET, OUTLET, CHECK DAM, SIDEWALK NOTCH, ETC.
- ELEVATIONS OF EVERY INLET, OUTLET, STRUCTURE RIM AND INVERT, CHECK DAM, PLANTER WALL CORNER, AND SIDEWALK NOTCH
- TYPE AND DESIGN OF PLANTER COMPONENTS (E.G., EDGE TREATMENTS, INLETS/GUTTER MODIFICATIONS, UTILITY CROSSINGS, LINER, AND PLANTING DETAILS)

REV.	REVISION DATE	APPROVED

BIORETENTION
DESIGN NOTES AND GUIDANCE

ISSUE DATE: FEBRUARY 2026
APPROVED BY: N. MEAD-FOX

BIORETENTION DRAWING DESCRIPTIONS

GI4.0A	BIORETENTION DESIGN NOTES	THE BIORETENTION DESIGN NOTES PROVIDE GUIDANCE TO DESIGNERS ON HOW TO ADAPT THE TEMPLATE STANDARDS.
GI4.0B	BIORETENTION DRAWING DESCRIPTIONS	THIS DRAWING DESCRIBES THE PURPOSE AND INTENDED USE OF EACH BIORETENTION DRAWING.
GI4.1	BIORETENTION PROFILE	THE BIORETENTION PROFILE IS A TEMPLATE PROFILE SECTION OF A BIORETENTION SYSTEM. BIORETENTION SYSTEMS MAY VARY SIGNIFICANTLY IN THEIR LENGTH AND DEPTH, BUT GENERALLY SHOULD INCLUDE THE COMPONENTS AND MATERIALS SHOWN ON THE DRAWING.
GI4.2	BIORETENTION BULGE WITHOUT ADJACENT BOULEVARD	THIS STANDARD SHOWS THE PLAN VIEW, CROSS-SECTION, AND RECOMMENDED DESIGN NOTES FOR A BIORETENTION BULGE WHERE THE VEGETATED AREA CANNOT EXTEND INTO THE EXISTING BOULEVARD.
GI4.3	BIORETENTION BULGE WITH ADJACENT BOULEVARD	THIS STANDARD IS AN ALTERNATE DESIGN OF GI4.2. AND IS TO BE USED WHEN THE VEGETATED AREA OF THE CELL CAN EXTEND INTO THE BOULEVARD.
GI4.4	CURB CUT SEDIMENT BASIN	CURB CUT SEDIMENT PADS ARE USED TO COLLECT ROADWAY SEDIMENT AND PREVENT EROSION IN THE GI SYSTEM DURING MAJOR STORMS. ADDITIONAL DETAILS ON CURB CUT OPENINGS ARE INCLUDED IN GI2.1 THROUGH GI2.6.
GI4.5	STRAIGHTAWAY SEDIMENT BASIN	THE STRAIGHTAWAY SEDIMENT PAD IS AN ALTERNATE DESIGN FOR BIORETENTION CELL WHERE THE PRIMARY INLET FLOW PATH FOLLOWS THE DIRECTION OF THE EXISTING CURB.
GI4.6	SEDIMENT BASIN WEIR WALL	THIS STANDARD SHOWS THE STRUCTURAL REINFORCEMENT AND BASE MATERIALS FOR THE WEIRS THAT CONTAIN FLOW IN THE SEDIMENT PAD AREA.
GI4.7	CONCRETE CHECK DAM	BIORETENTION SYSTEMS SHOULD MAXIMIZE THE FLAT AREA OF THE CELL, ALSO REFERRED TO AS THE "PONDED AREA". CONCRETE CHECK DAMS ARE USED TO INCREASE THE PONDED SURFACE AREA WHEN THE ELEVATION CHANGE ALONG THE ADJACENT ROADWAY LEADS TO AN UNACCEPTABLY HIGH DROP AT THE UPSTREAM END OF THE CELL.

REV.	REVISION DATE	APPROVED

BIORETENTION
BIORETENTION DRAWING DESCRIPTIONS

ISSUE DATE: FEBRUARY 2026
APPROVED BY: N. MEAD-FOX

DRAWING No.

GI4.1

STANDARD DETAIL DRAWINGS
ENGINEERING SERVICES - VANCOUVER, B.C.

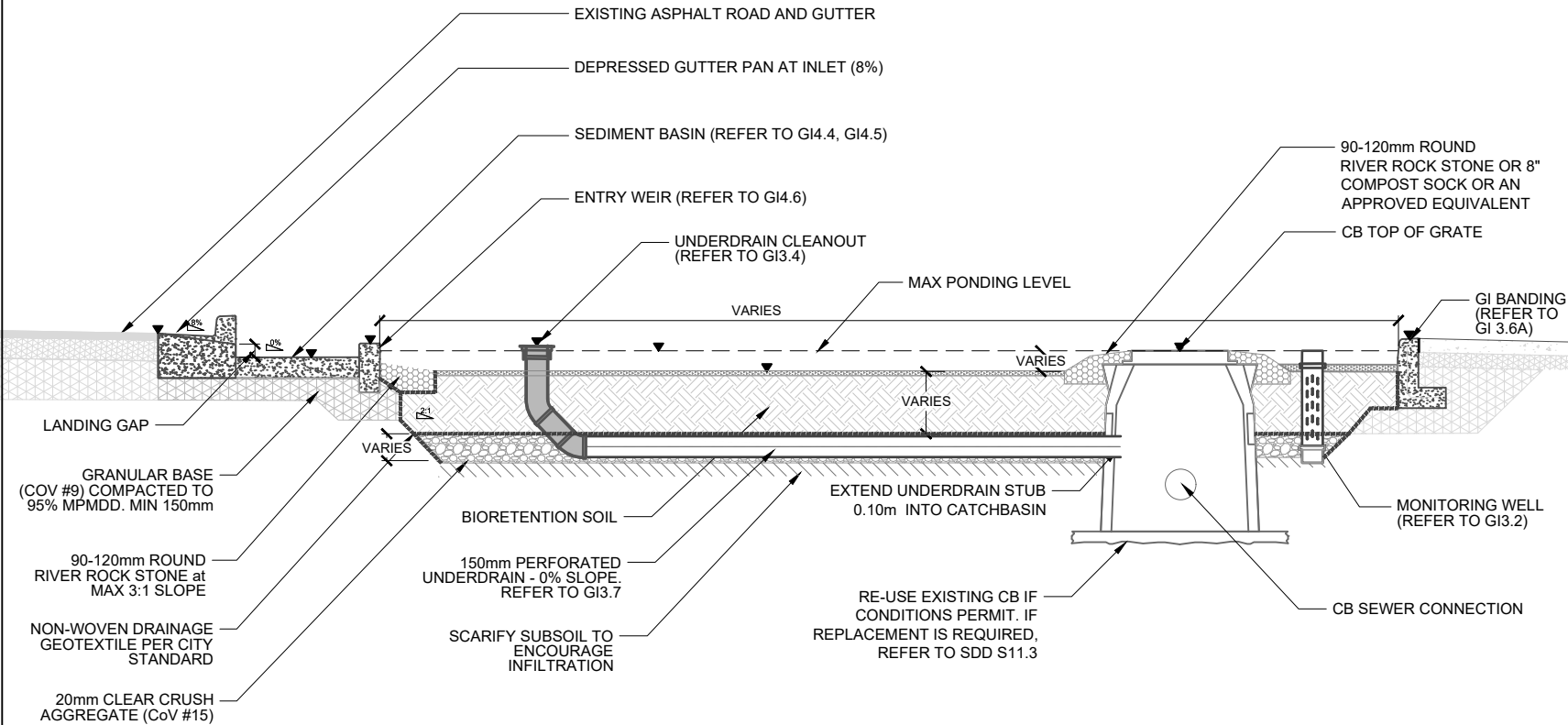

Cell Layer	Recommended Layer Thickness (m)
Composted Mulch	0.05-0.075
Bioretention Soil	0.45-1.00
Aggregate/Bedding	0.20-0.40
Geotextile	N/A

ISSUE DATE: FEBRUARY 2026
APPROVED BY: N. MEAD-FOX

BIORETENTION
BIORETENTION PROFILE

- LANDING GAP
- GRANULAR BASE (COV #9) COMPACTED TO 95% MPMD. MIN 150mm
- 90-120mm ROUND RIVER ROCK STONE at MAX 3:1 SLOPE
- NON-WOVEN DRAINAGE GEOTEXTILE PER CITY STANDARD
- 20mm CLEAR CRUSH AGGREGATE (CoV #15)

- BIORETENTION SOIL
- 150mm PERFORATED UNDERDRAIN - 0% SLOPE. REFER TO GI3.7
- SCARIFY SUBSOIL TO ENCOURAGE INFILTRATION

- EXTEND UNDERDRAIN STUB 0.10m INTO CATCHBASIN
- RE-USE EXISTING CB IF CONDITIONS PERMIT. IF REPLACEMENT IS REQUIRED, REFER TO SDD S11.3

- 90-120mm ROUND RIVER ROCK STONE OR 8" COMPOST SOCK OR AN APPROVED EQUIVALENT
- CB TOP OF GRATE
- GI BANDING (REFER TO GI 3.6A)
- MONITORING WELL (REFER TO GI3.2)
- CB SEWER CONNECTION

NOTES

1. LABEL AND DISPLAY ALL UTILITIES AND/OR SERVICES THAT CROSS BELOW OR THROUGH THE BIORETENTION PROFILE ALONG WITH THEIR OBVERT ELEVATIONS
2. SHOW ALL UTILITY PROTECTION MEASURES AND SETBACKS FOR SERVICES AND/OR UTILITY CONFLICTS
3. GRADING DESIGN SHOULD USE 3:1 SLOPES IN THE VEGETATED AREA TO MAXIMIZE THE FLAT AREA WITHIN THE SYSTEM THAT IS AVAILABLE FOR PONDING.
4. ▼ INDICATES ELEVATION POINTS THAT SHOULD BE SHOWN ON DESIGN DRAWINGS
5. THE CONTRACTOR IS TO PROVIDE PRE-SURVEY OF THE EXISTING CATCH BASIN (CB) CONDITIONS. THE PICTURES OF CBS (INSIDE AND OUTSIDE) , WELL ORGANIZED AND CORRELATED WITH THE CB LOCATION, ARE SUFFICIENT.
6. CORE OPENING IN THE EXISTING CB WALL TO SUIT PVC PERFORATED PIPE CONNECTION. GROUT ANNULAR OPENING AROUND THE PIPE WITH NON-SHRINK GROUT.
7. COV REPRESENTATIVE (SEWER MAINTENANCE INSPECTOR) SHALL INSPECT AND APPROVE THE CONNECTION PRIOR TO THE PIPE BEING BURIED. CONTACT SEWERS AT 604-871-6170 TO ARRANGE FOR INSPECTION. PROVIDE AT LEAST 48 HOURS NOTIFICATION.
8. THE TOTAL DEPTH OF BIORETENTION SYSTEMS SHOULD NOT EXCEED 1.2m BELOW THE EXISTING GRADE.

REV	REVISION DATE	APPROVED

CONCEPTUAL AXONOMETRIC

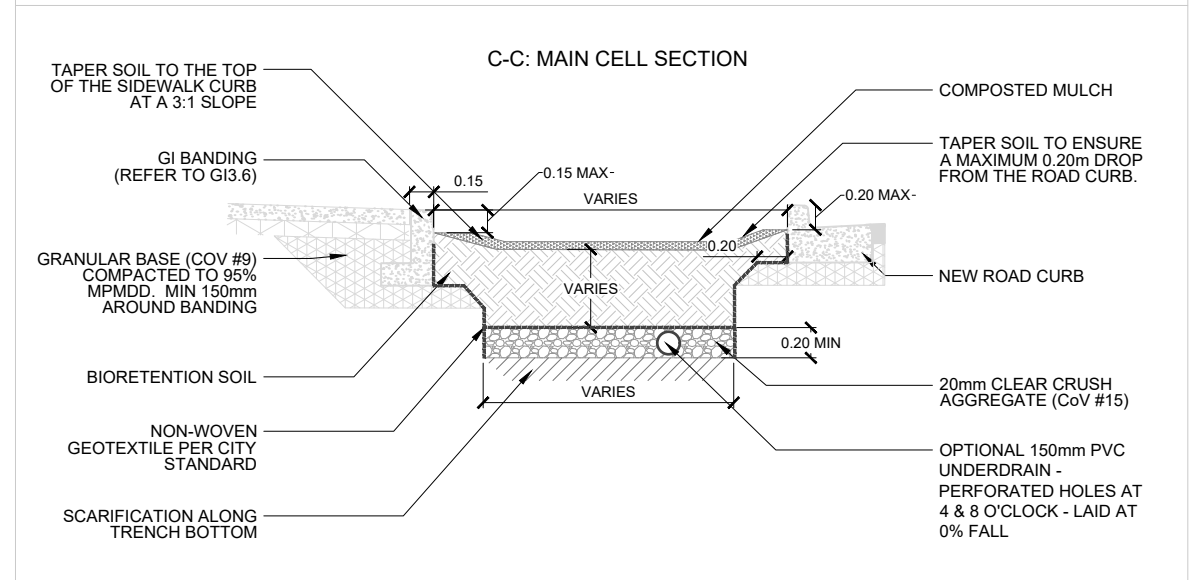
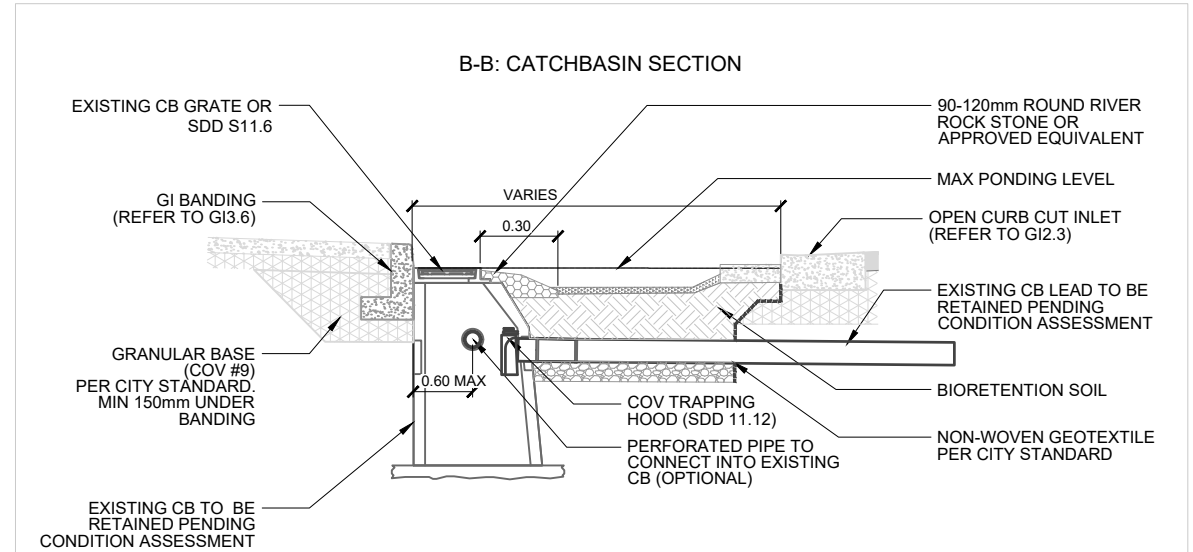
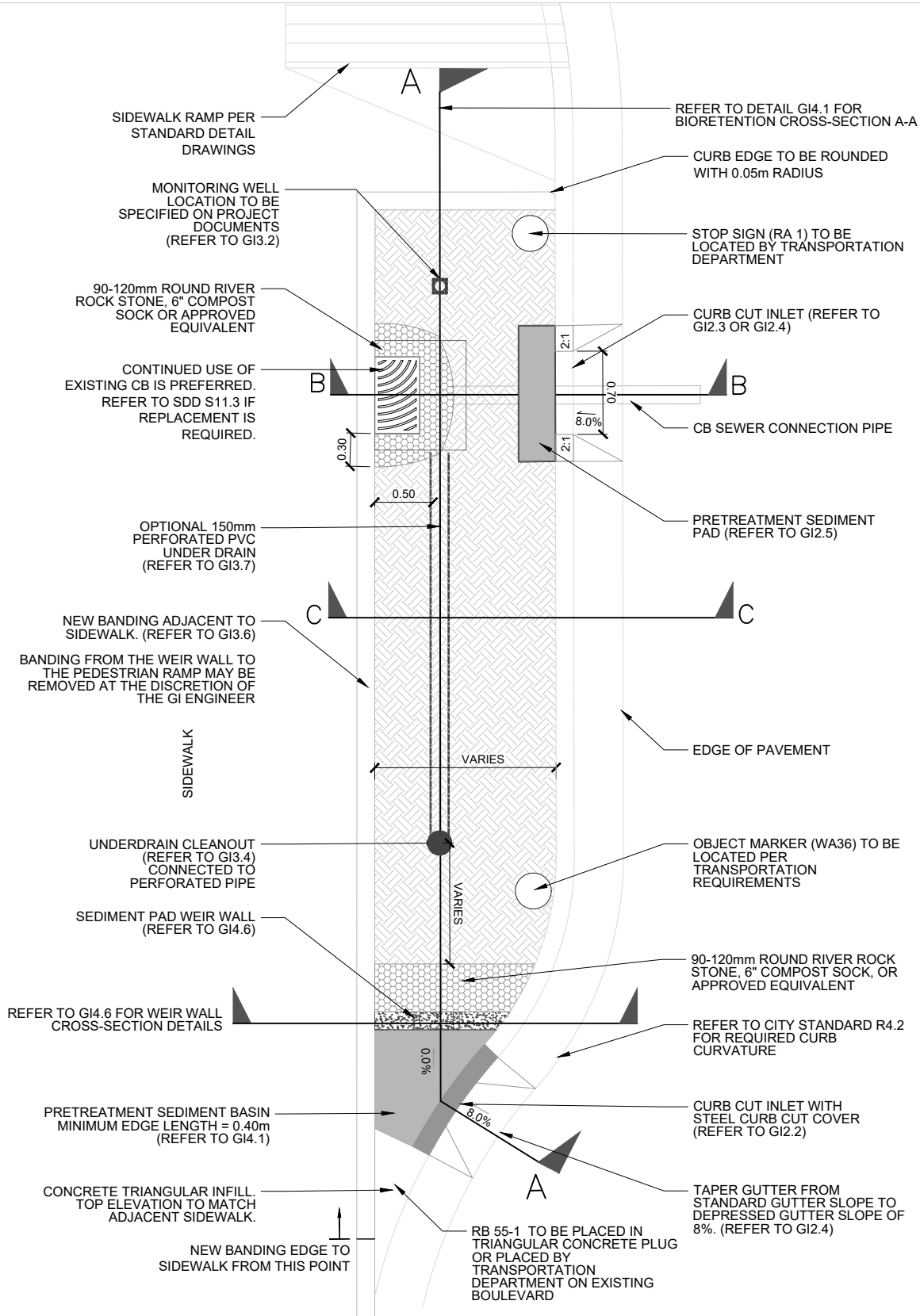
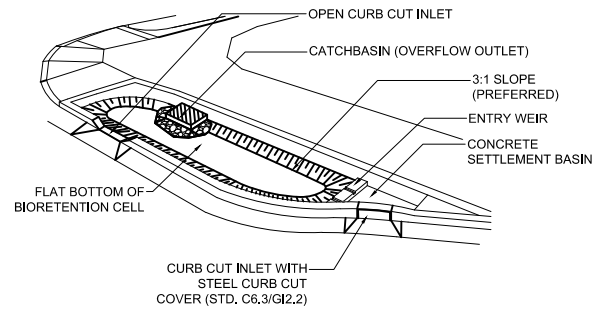

BIORETENTION
BIORETENTION BULGE WITHOUT ADJACENT BOULEVARD

REV.	REVISION DATE	APPROVED

ISSUE DATE: FEBRUARY 2026
APPROVED BY: N. MEAD-FOX

CONCEPTUAL AXONOMETRIC

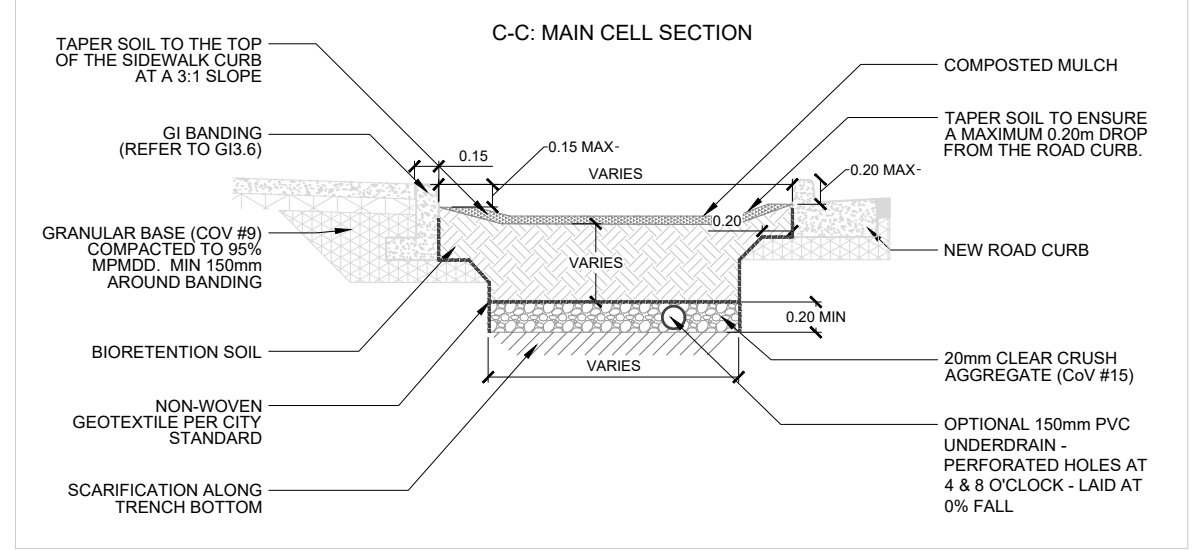
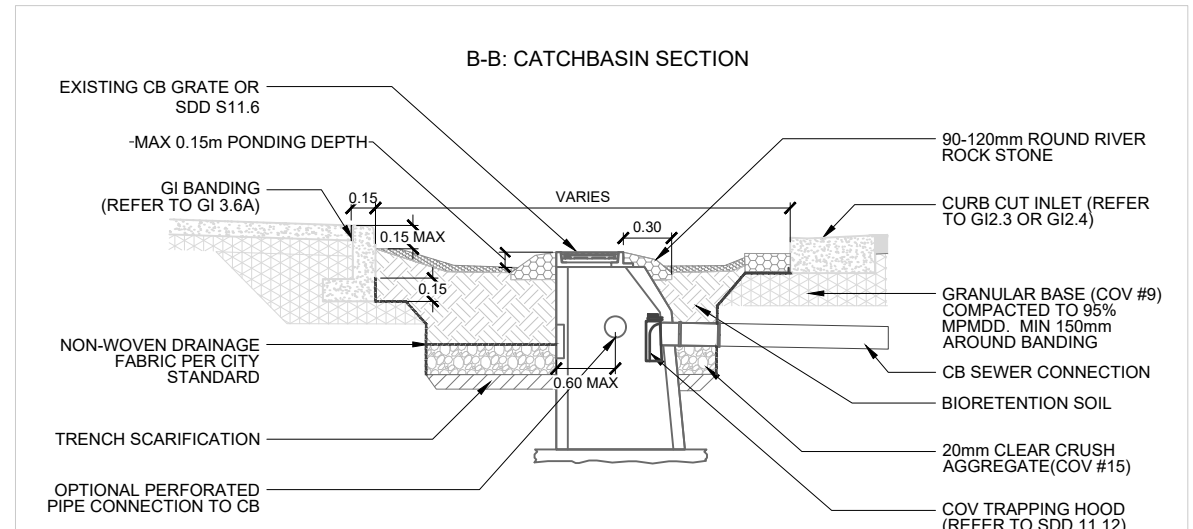
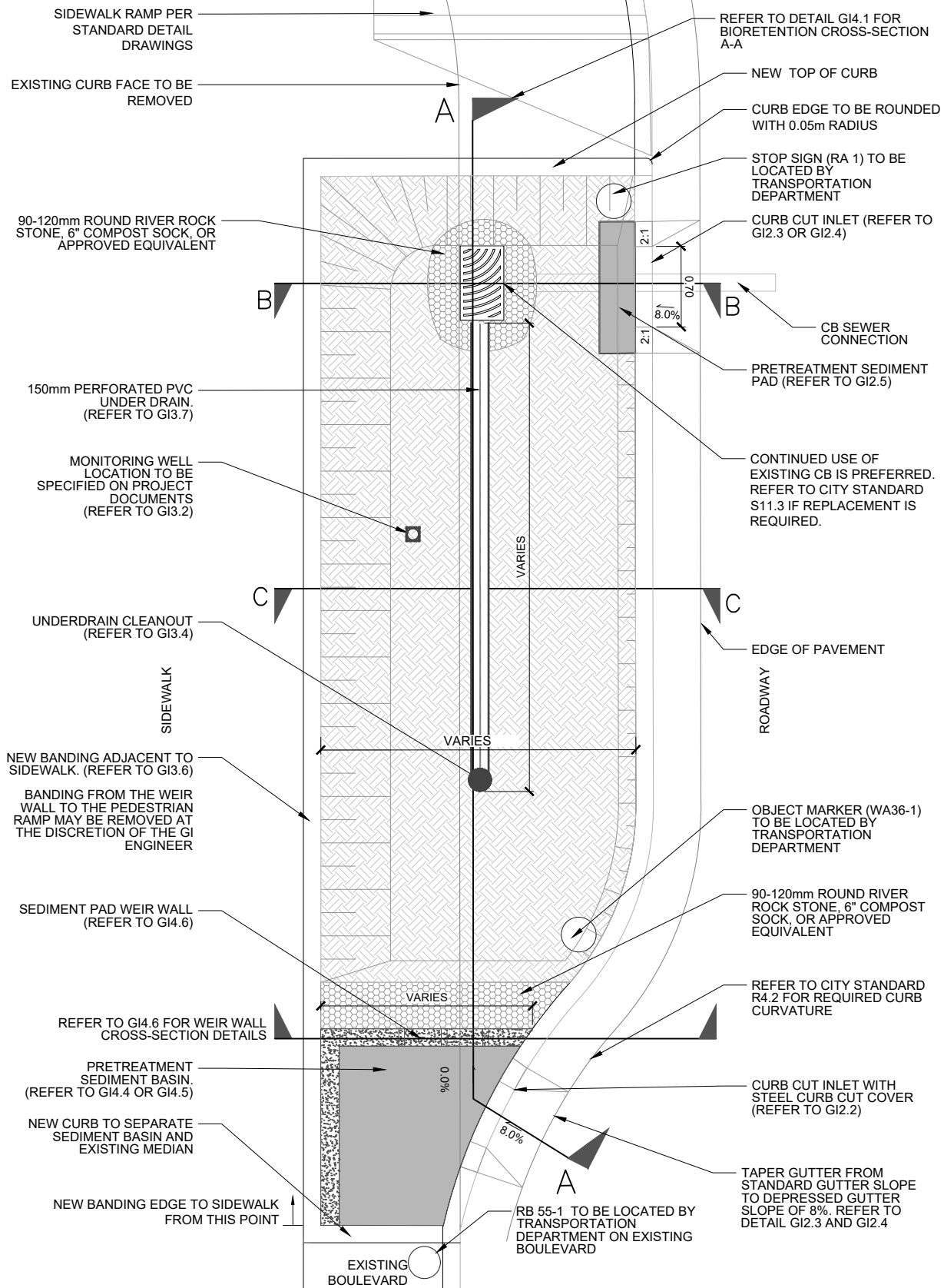
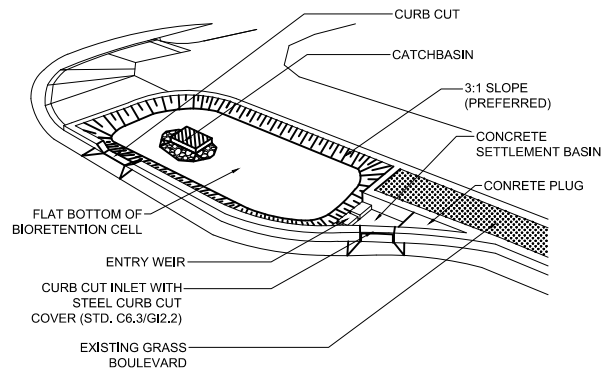

BIORETENTION
BIORETENTION BULGE WITH ADJACENT BOULEVARD

ISSUE DATE: FEBRUARY 2026
APPROVED BY: N. MEAD-FOX

REV.	REVISION DATE	APPROVED

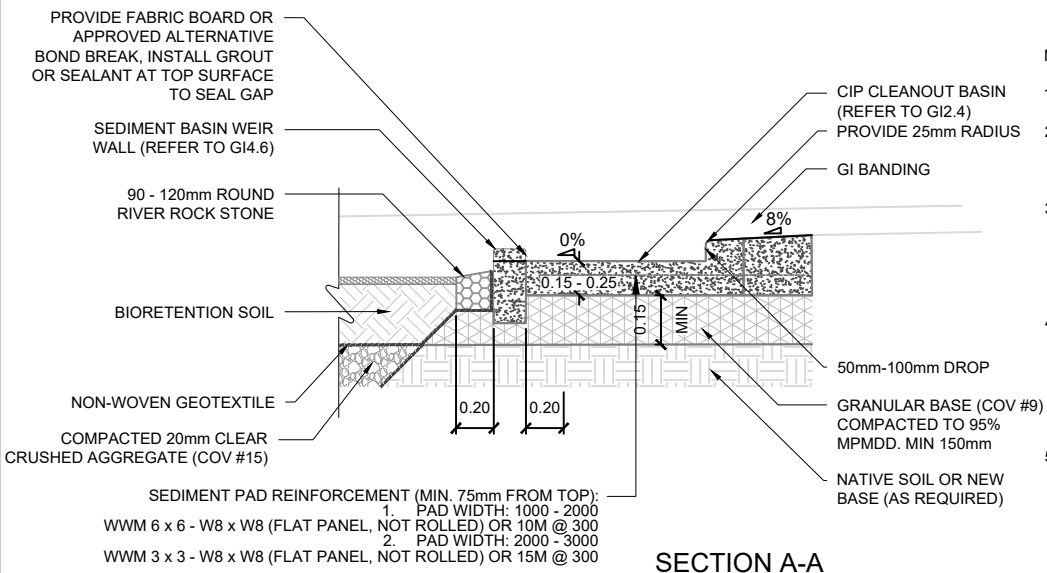
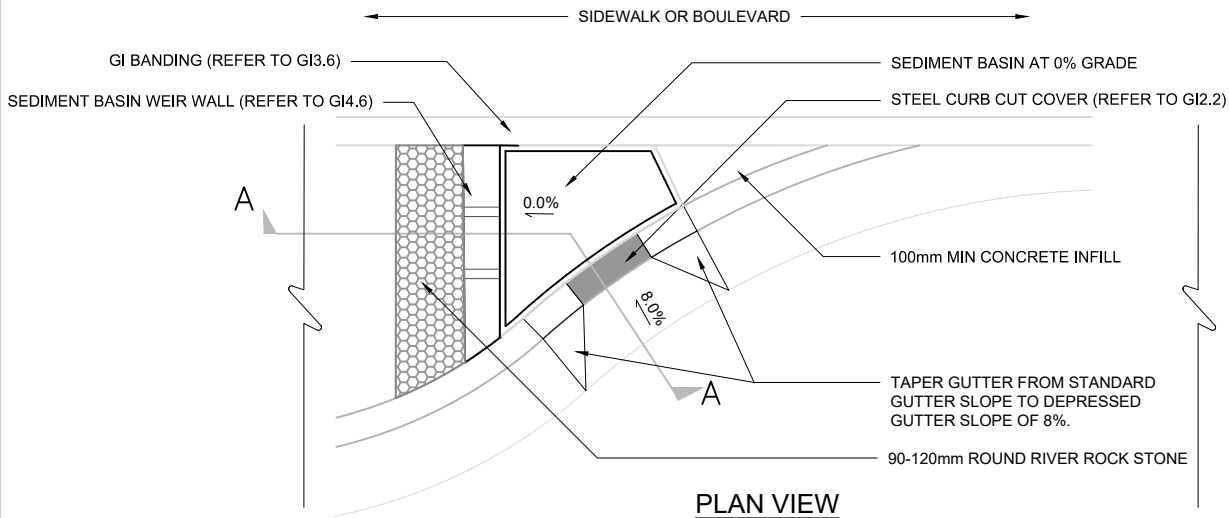
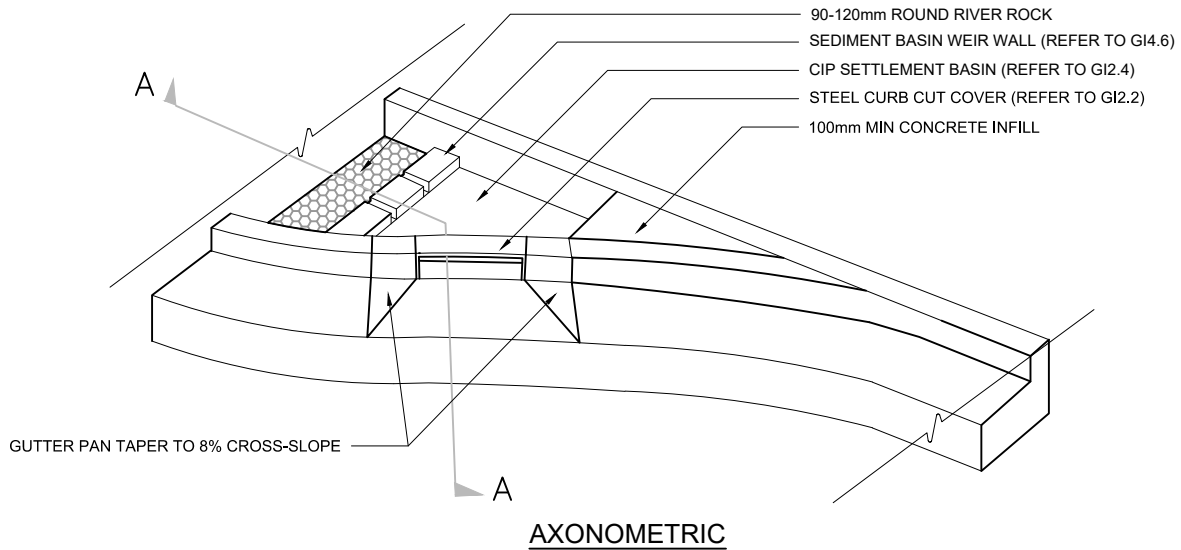

NOTES:

1. THIS DETAIL TO BE READ IN CONJUNCTION WITH DRAWING GI4.6.
2. INSTALL EMBEDDED REINFORCEMENT AND CONCRETE IN CONFORMANCE WITH CITY OF VANCOUVER CONSTRUCTION SPECIFICATIONS.
3. STRUCTURAL MEMBER SIZING AND ORIENTATION OF ELEMENT TO BE CONFIRMED BY THE ENGINEER. REINFORCEMENT TO BE INSTALLED AS OUTLINED IN THIS DRAWING, UNLESS OTHERWISE NOTED BY THE ENGINEER.
4. CONNECTION OF SEDIMENT BASIN TO GI BANDING IS NOT REQUIRED UNLESS NOTED BY THE ENGINEER. CONNECTION TO INLET APRON NOT REQUIRED EXCEPT FOR EXTENSION OF SEDIMENT BASIN REINFORCEMENT, AS SHOWN IN THIS DETAIL.
5. NOTIFY THE ENGINEER IF EXISTING SITE CONDITIONS DIFFER FROM THOSE SHOWN IN THIS DETAIL.

SECTION A-A

REV.	REVISION DATE	APPROVED

**BIORETENTION
CURB CUT SEDIMENT BASIN**

ISSUE DATE: FEBRUARY 2026

APPROVED BY: N. MEAD-FOX

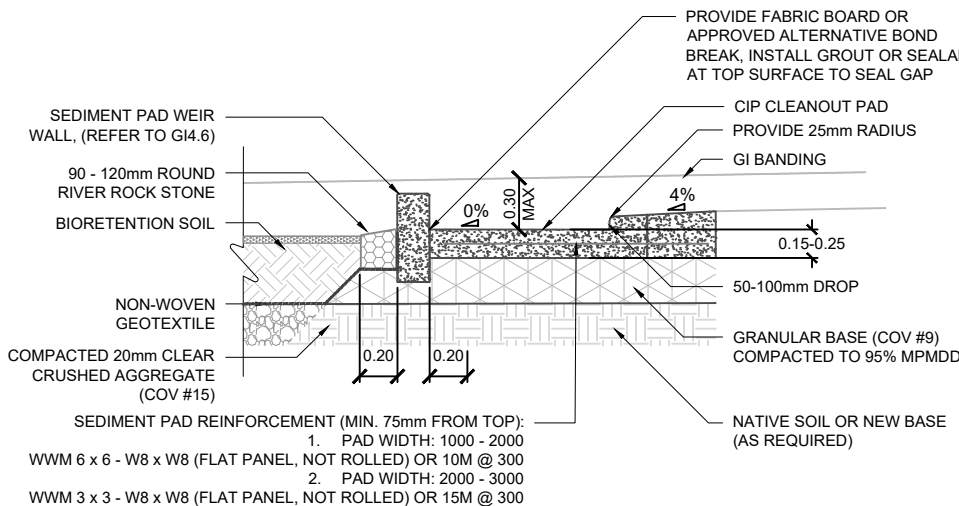
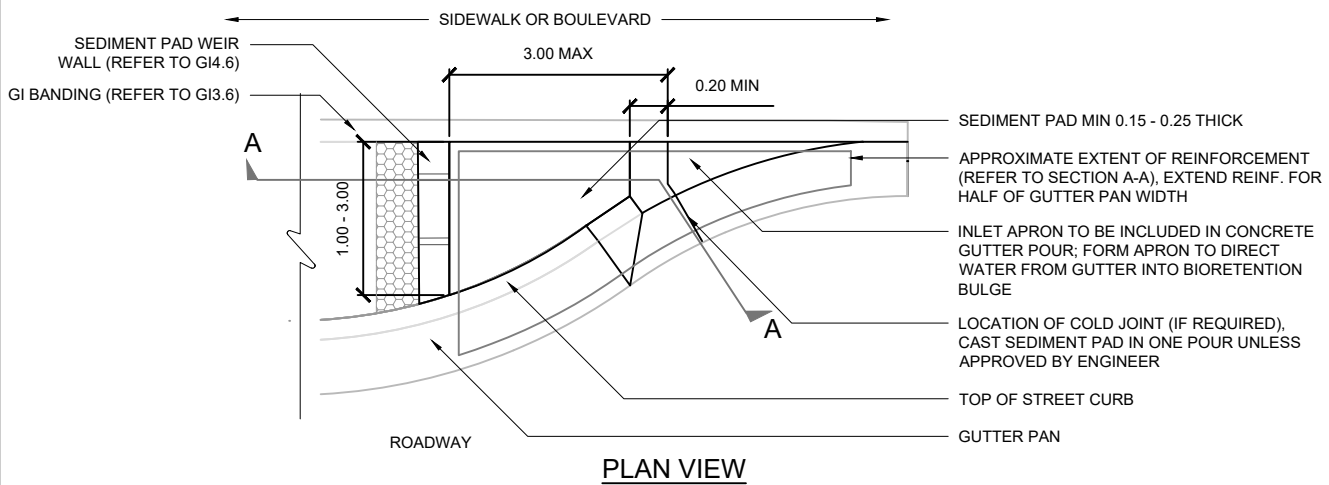
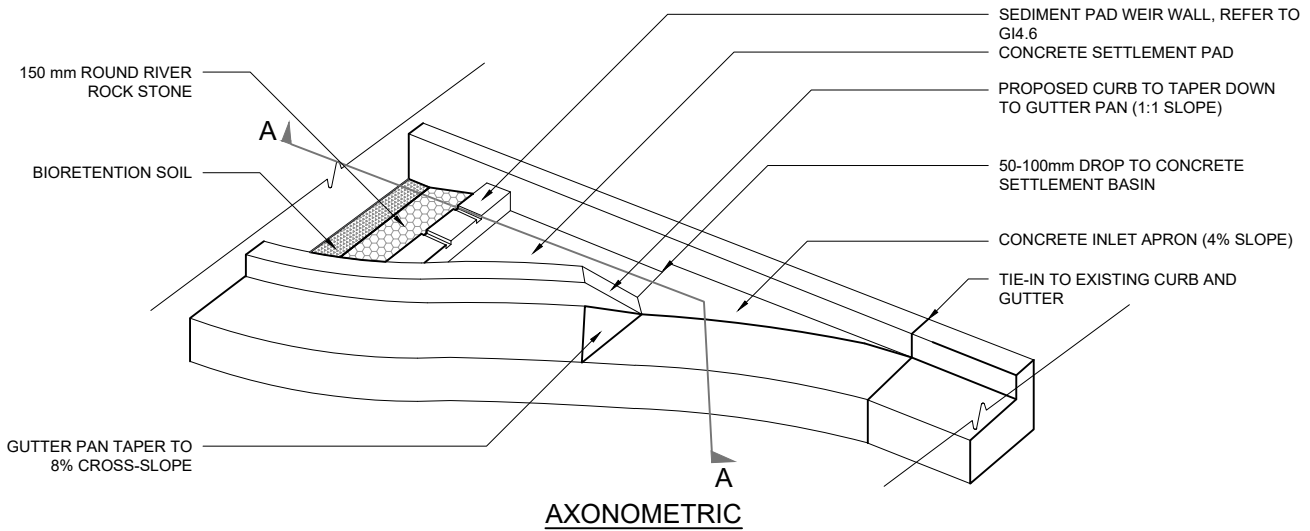

NOTES:

1. THIS DETAIL TO BE READ IN CONJUNCTION WITH DRAWING GI4.6.
2. REFER TO DESIGN MEMO FOR THIS STANDARD DETAIL WHICH OUTLINES DESIGN CRITERIA AND APPLIED LOADING.
3. INSTALL EMBEDDED REINFORCEMENT AND CONCRETE IN CONFORMANCE WITH CITY OF VANCOUVER CONSTRUCTION SPECIFICATIONS.
4. STRUCTURAL MEMBER SIZING AND ORIENTATION OF ELEMENT TO BE CONFIRMED BY THE ENGINEER. REINFORCEMENT TO BE INSTALLED AS OUTLINED IN THIS DRAWING, UNLESS OTHERWISE NOTED BY THE ENGINEER.
5. CONNECTION OF SEDIMENT PAD TO GI BANDING IS NOT REQUIRED UNLESS NOTED BY THE ENGINEER. CONNECTION TO INLET APRON NOT REQUIRED EXCEPT FOR EXTENSION OF SEDIMENT PAD REINFORCEMENT, AS SHOWN IN THIS DETAIL.
6. NOTIFY THE ENGINEER IF EXISTING SITE CONDITIONS DIFFER FROM THOSE SHOWN IN THIS DETAIL.

REV.	REVISION DATE	APPROVED

**BIORETENTION
STRAIGHTAWAY SEDIMENT PAD**

ISSUE DATE: FEBRUARY 2026

APPROVED BY: N. MEAD-FOX

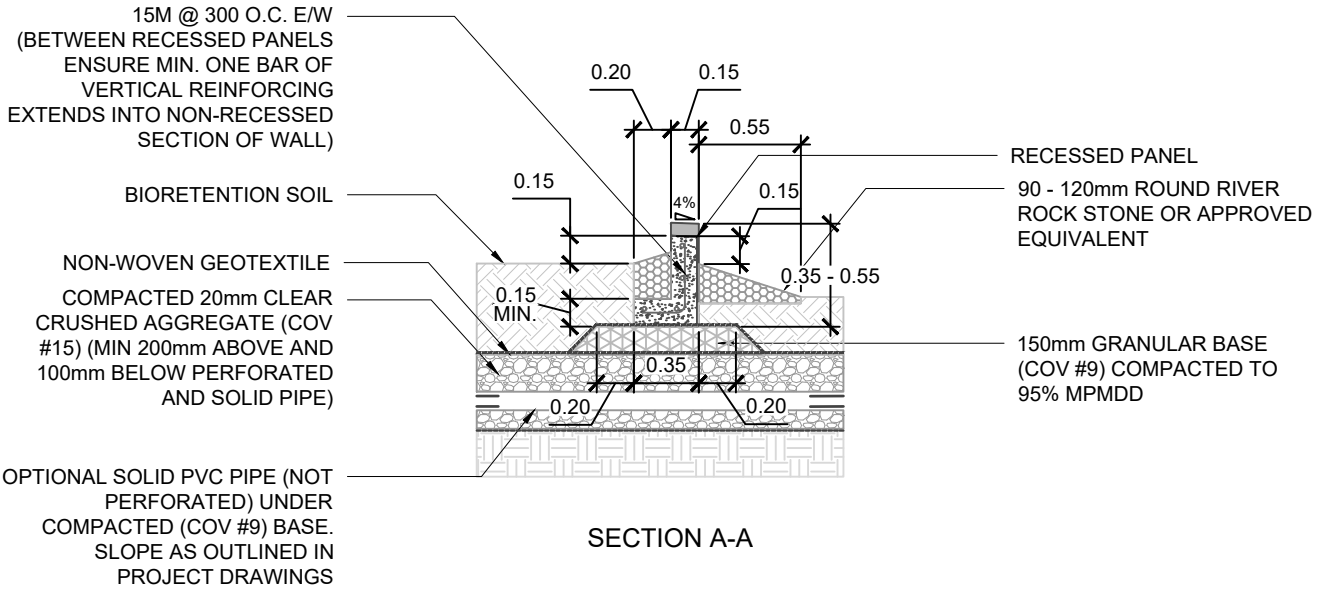
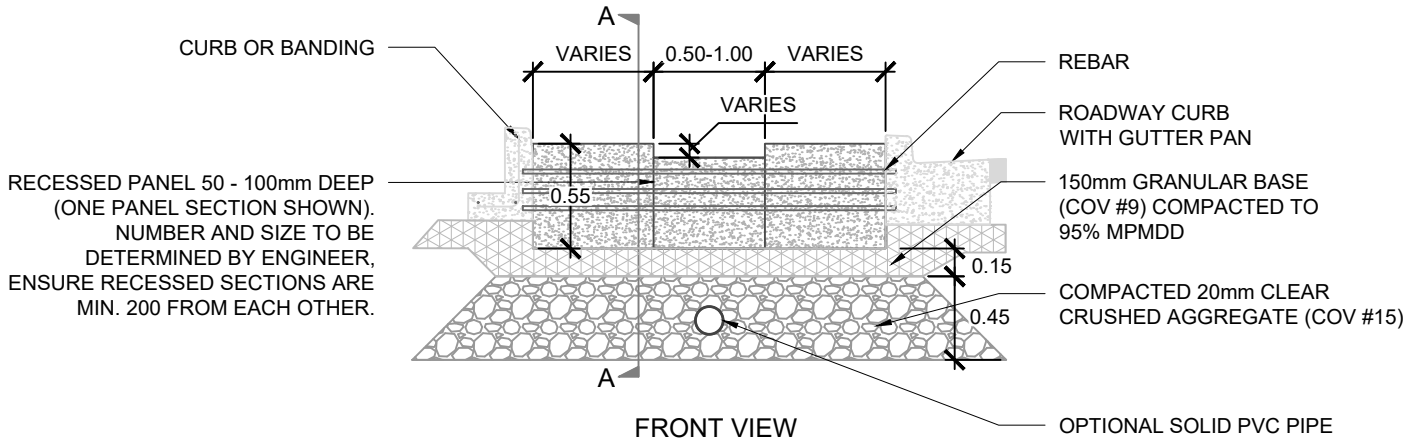

- NOTES:**
- HAND-TAMP 20mm CLEAR CRUSHED AGGREGATE AND GRANULAR BASE WITHIN 300mm OF PERFORATED PIPE TO AVOID DAMAGE.
 - INSTALL EMBEDDED REINFORCEMENT AND CONCRETE IN CONFORMANCE WITH CITY OF VANCOUVER CONSTRUCTION SPECIFICATIONS.
 - STRUCTURAL MEMBER SIZING AND ORIENTATION OF ELEMENT TO BE CONFIRMED BY THE ENGINEER. REINFORCEMENT TO BE INSTALLED AS OUTLINED IN THIS DRAWING, UNLESS OTHERWISE NOTED BY THE ENGINEER.
 - NOTIFY THE ENGINEER IF EXISTING SITE CONDITIONS DIFFER FROM THOSE SHOWN IN THIS DETAIL.

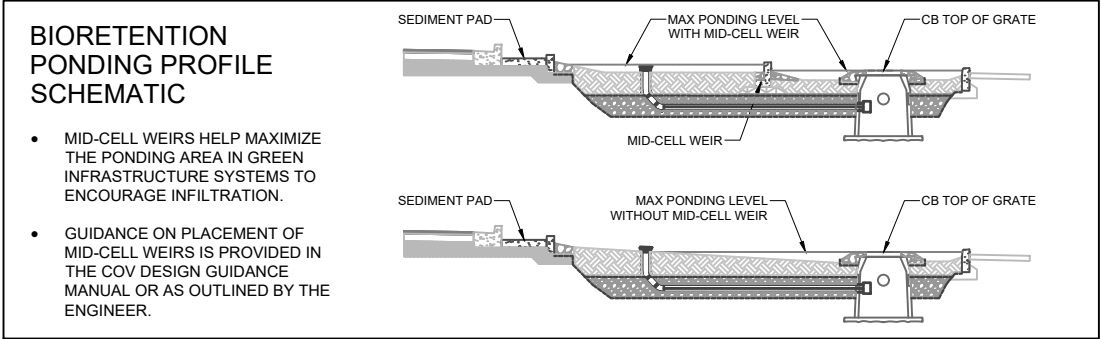

- BIORETENTION PONDING PROFILE SCHEMATIC**
- MID-CELL WEIRS HELP MAXIMIZE THE PONDING AREA IN GREEN INFRASTRUCTURE SYSTEMS TO ENCOURAGE INFILTRATION.
 - GUIDANCE ON PLACEMENT OF MID-CELL WEIRS IS PROVIDED IN THE COV DESIGN GUIDANCE MANUAL OR AS OUTLINED BY THE ENGINEER.

REV.	REVISION DATE	APPROVED

BIORETENTION CONCRETE CHECK DAM

ISSUE DATE: FEBRUARY 2026
APPROVED BY: N. MEAD-FOX

RAINWATER TREE TRENCH DESIGN NOTES AND GUIDANCE

PURPOSE:

RAINWATER TREE TRENCHES (RTT) RETAIN RAINWATER RUNOFF BY PROVIDING SURFACE, SUBSURFACE STORAGE AND INFILTRATION INTO NATIVE SOIL. WATER IS ALSO TREATED AS IT FILTERS THROUGH THE SOIL AND THE ROOTS WITHIN THE TREE TRENCH.

DESIGNER NOTES & GUIDELINES:

- THE DESIGNER MUST ADAPT PLAN AND SECTION DRAWINGS TO ADDRESS SITE-SPECIFIC CONDITIONS.
- RTT SURFACE AREA, PONDING DEPTH, BIORETENTION SOIL DEPTH, AND AGGREGATE STORAGE DEPTH MUST BE SIZED TO MEET PROJECT HYDROLOGIC PERFORMANCE GOALS.
- REQUIREMENTS FOR PONDING AND SYSTEM DRAWDOWN TIME (i.e., TIME FOR MAXIMUM SURFACE PONDING TO DRAIN THROUGH THE BIORETENTION SOIL AFTER THE END OF A STORM):
 - 24 HOUR MAXIMUM SURFACE PONDING DRAWDOWN
 - 72 HOUR MAXIMUM DRAWDOWN FOR RTT SOIL AND AGGREGATE STORAGE
- RTT'S MAY BE DESIGNED USING STRUCTURAL SOIL OR MANUFACTURED SOIL CELLS. STRUCTURAL SOIL AND SOIL CELLS MUST MEET CITY OF VANCOUVER SPECIFICATIONS REGARDING LOADING CAPACITY OF RIGHT-OF-WAY INFRASTRUCTURE.
- WHEN FACILITY CONSTRUCTION IMPACTS EXISTING SIDEWALK, ALL SAW CUTS MUST ADHERE TO CoV REQUIREMENTS. SAW CUTS SHOULD BE ALONG SCORE LINES AND ANY DISTURBED SIDEWALK PANELS SHOULD BE REPLACED IN THEIR ENTIRETY.
- GI FACILITIES IN PUBLIC RIGHT OF WAY SHALL BE DESIGNED WITH A SAFE, DESIGNATED OVERLAND FLOW PATH TO THE STREET IN THE EVENT THAT THE OVERFLOW STRUCTURE IS OBSTRUCTED OR CLOGGED. THIS FLOW PATH SHOULD BE REFLECTED IN SITE GRADING AND LABELED ON GI DRAWINGS.
- THE DESIGNER MUST EVALUATE UTILITY SURVEYS FOR POTENTIAL UTILITY CROSSINGS OR CONFLICTS. MINIMUM UTILITY SETBACKS AND PROTECTION MEASURES MUST CONFORM TO CURRENT CITY OF VANCOUVER ASSET PROTECTION STANDARDS AND OTHER UTILITY PROVIDER REQUIREMENTS.
- VEGETATION MUST BE SPECIFIED BY DESIGN PROFESSIONAL PER CoV GREEN INFRASTRUCTURE PLANTING GUIDELINES. TREE SPECIES MUST BE CONFIRMED WITH PARKS BOARD STAFF
- CLEANOUTS OR INSPECTION CHAMBERS ARE REQUIRED AT INTERMEDIATE LOCATIONS ALONG DISTRIBUTION PIPES WHERE THE LENGTH OF THE DISTRIBUTION PIPE IS >45m SUCH THAT NO UNINTERRUPTED LENGTH OF DISTRIBUTION PIPE IS GREATER THAN 45m.
- INSPECTION CHAMBERS ARE REQUIRED IN PLACE OF A 90-BEND OR T-JOINT
- ALL INTERMEDIARY CLEANOUTS SHALL FACE UPSTREAM/UP GRADIENT PER GI3.4

LAYOUT REQUIREMENTS:

- REFER TO THE CITY OF VANCOUVER ACCESSIBILITY STRATEGY, STANDARD DRAWINGS AND CONSTRUCTION SPECIFICATIONS FOR RIGHT-OF-WAY, PARKING SPACE, AND ACCESSIBLE PATH REQUIREMENTS.
- LOCATE CURB CUTS AND GUTTER MODIFICATIONS TO AVOID CONFLICTS WITH ACCESSIBILITY REQUIREMENTS (E.G., LOCATE OUTSIDE OF CROSSWALKS).
- IDENTIFY ALL SIGN AND POST LOCATIONS WITHIN THE GI AREA AND ENSURE PROPER BACKFILL MATERIALS ARE PRESENT TO SUPPORT ALL SIGN BASES.

DESIGNER CHECKLIST (MUST SPECIFY, AS APPLICABLE):

- EXTENT AND VOLUME OF STRUCTURAL SOIL
- DEPTH OF PONDING
- DEPTH OF FREEBOARD
- DEPTH OF SYSTEM
- DEPTH AND TYPE OF AGGREGATE STORAGE, IF ANY
- SURFACE ELEVATION AT UPSLOPE AND DOWNSLOPE ENDS OF FACILITY
- DIMENSIONS AND DISTANCE TO EVERY MUNICIPAL SERVICE/UTILITY WITHIN 10m OF THE FACILITY
- ELEVATIONS OF EVERY INLET, OUTLET, STRUCTURE RIM AND INVERT,
- TYPE AND DESIGN OF COMPONENTS (E.G., EDGE TREATMENTS, INLETS/GUTTER MODIFICATIONS, UTILITY CROSSINGS, LINER, AND PLANTING DETAILS)

RELATED DETAILS

EDGE TREATMENTS:	GI 3.5	-	GI 3.6
INLETS:	GI 2.1	-	GI 2.5
UNDERDRAINS:	GI 3.7		
CHECK DAMS:	GI 4.7		
MONITORING WELL	GI 3.2		
CLEANOUTS:	GI 3.4		
INSPECTION CHAMBERS	GI 3.3		
CATCHBASINS	GI 3.1	GI 3.8	S 11.2

RELATED SPECIFICATIONS	COV SPEC NO.
- BIORETENTION SOIL	***
- RAINWATER TREE TRENCHES	***
- STRUCTURAL SOIL	***
- AGGREGATES AND GRANULAR MATERIALS	31 05 17
- DRAINAGE FABRIC	31 32 19

***TEMPLATE ONLY. AVAILABLE UPON REQUEST FROM THE GI BRANCH.

REV.	REVISION DATE	APPROVED

RAINWATER TREE TRENCHES DESIGN NOTES AND GUIDANCE

ISSUE DATE: FEBRUARY 2026

APPROVED BY: N. MEAD-FOX

RAINWATER TREE TRENCH (RTT) DRAWING DESCRIPTIONS

GI5.0A	RAINWATER TREE TRENCH DESIGN NOTES	THE RAINWATER TREE TRENCH DESIGN NOTES PROVIDE GUIDANCE TO DESIGNERS ON HOW TO USE AND ADAPT THE TEMPLATE STANDARDS IN THIS SECTION.
GI5.0B	RAINWATER TREE TRENCH DRAWING DESCRIPTIONS	THIS PAGE DESCRIBES THE PURPOSE AND INTENDED USE OF EACH RAINWATER TREE TRENCH DRAWING.
GI5.1	RAINWATER TREE TRENCH LAYOUT	THE RAINWATER TREE TRENCH LAYOUT STANDARD PROVIDES PLAN AND PROFILE DRAWINGS OF A TYPICAL TREE TRENCH, ALONG WITH A CONCEPTUAL AXONOMETRIC DIAGRAM. THE STANDARD PROVIDES AN EXAMPLE OF ONE SECTION OF A TREE TRENCH. THE DESIGN MAY BE EXTENDED IN EITHER DIRECTION AND ALONG THE FULL LENGTH OF A CITY BLOCK.
GI5.2	RTT INSPECTION CHAMBER	THIS STANDARD PROVIDES ADDITIONAL DETAILS ON HOW INSPECTION CHAMBERS (GI3.3.) CAN BE CONNECTED CATCHBASINS IN THE ROADWAY AND INTEGRATED INTO TREE PIT DESIGN. IT HIGHLIGHTS THE SEWER DESIGN CONSTRAINTS OF THESE SYSTEMS AND THE IMPACT OF INVERT ELEVATIONS ON TREE TRENCH SATURATION LEVELS.
GI5.3	STRUCTURAL SOIL ADJACENT TO RTT	GI5.3. DEPICTS THE INTERFACE BETWEEN RAINWATER TREE TRENCH AREAS WITHIN THE BOULEVARD AND ADJACENT SIDEWALKS OR BIKELANES WITH UNDERLYING STRUCTURAL SOIL. STRUCTURAL SOIL IS USED TO PROVIDE SUFFICIENT SOIL VOLUME FOR STREET TREES WHILE PROVIDING STRUCTURAL SUPPORT FOR ADJACENT PAVED SURFACES.
GI5.4	GI SWALE BOULEVARD WITH STREET TREES	RAINWATER TREE TRENCHES MAY BE DESIGNED WITH A VARIETY OF DIFFERENT SURFACE TREATMENTS. GI5.4 DEPICTS A RAINWATER TREE TRENCH WHERE THE BOULEVARD SPACE BETWEEN TREES IS VEGETATED. THE TREE TRENCH CROSS-SECTIONS PROVIDE ADDITIONAL DETAILS ON TREE DESIGN, LAYERING, COMPONENTS, AND INTEGRATION WITH ADJACENT STRUCTURAL SOIL.
GI5.5	GI TREE PIT WITH STRUCTURAL SOIL	GI5.5 DEPICTS A RAINWATER TREE TRENCH WHERE THE SPACE BETWEEN TREES IS COVERED WITH A PAVEMENT OR PAVER SURFACE TREATMENT. THIS DESIGN VARIANT IS APPROPRIATE IN HIGH DENSITY AREAS WITH SIGNIFICANT FOOT TRAFFIC AND IN AREAS WITH ADJACENT STREET PARKING. ROADWAY RUNOFF IS DIRECTED TO THE TREES THROUGH A DISTRIBUTION PIPE (REFER TO GI5.6.) AND THROUGH SURFACE LEVEL CURB CUTS INTO THE TREE PIT AREAS.
GI5.6	GI TREE PIT WITH DISTRIBUTION PIPE	ROADWAY RUNOFF MAY BE DIRECTED INTO RAINWATER TREE TRENCHES THROUGH A PERFORATED DISTRIBUTION PIPE THAT RUNS ALONG THE TRENCH AND THROUGH THE TREE PLANTING AREAS. GI5.6. DEPICTS A TREE PIT WITH WITH A DISTRIBUTION PIPE PASSING THROUGH THE TREE PIT AREA. THE DRAWING INCLUDES INFORMATION ON INTEGRATION WITH ADJACENT STRUCTURAL SOIL.
GI5.7	VERTICAL EDGE RTT CROSS-SECTIONS	GI5.7. DEPICTS A TREE PIT WITH A VERTICAL INTERFACE BETWEEN THE ROADWAY AND THE RTT AREAS. IN CONSTRAINED BOULEVARD SPACES, IT MAY BE NECESSARY TO OPTIMIZE THE SOIL VOLUME AVAILABLE TO STREET TREES. THIS MAY BE ACHIEVED BY EXCAVATING VERTICALLY FROM THE BACK OF CURB INSTEAD OF RETAINING A SLOPED CURB BASE AND SUB-BASE. THE USE OF VERTICAL EDGES IS ONLY ACCEPTABLE IN LOW-RISK AREAS AND REQUIRES APPROVAL FROM STREETS DESIGN STAFF AND THE PROJECT ENGINEER.

REV.	REVISION DATE	APPROVED

**RAINWATER TREE TRENCHES
RTT DRAWING DESCRIPTIONS**

ISSUE DATE: FEBRUARY 2026
APPROVED BY: N. MEAD-FOX

CONCEPTUAL AXONOMETRIC

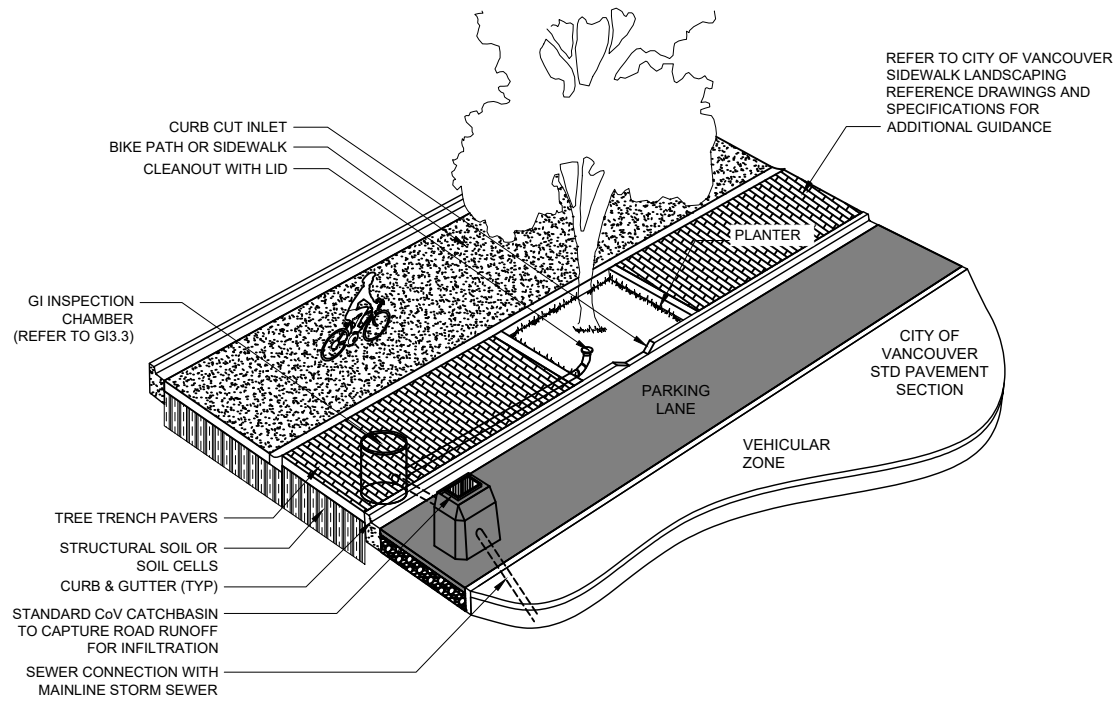

EXAMPLE LAYOUT - RAINWATER TREE TRENCH PLAN VIEW

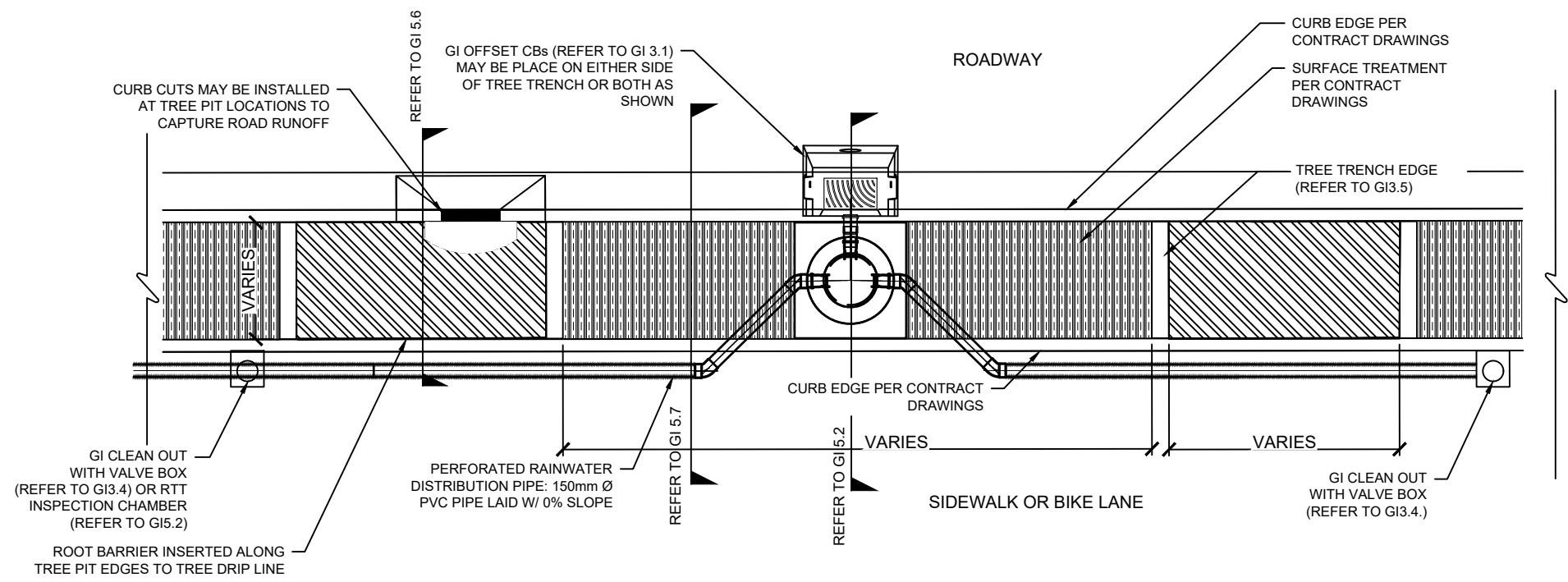

EXAMPLE LAYOUT - RAINWATER TREE TRENCH PROFILE

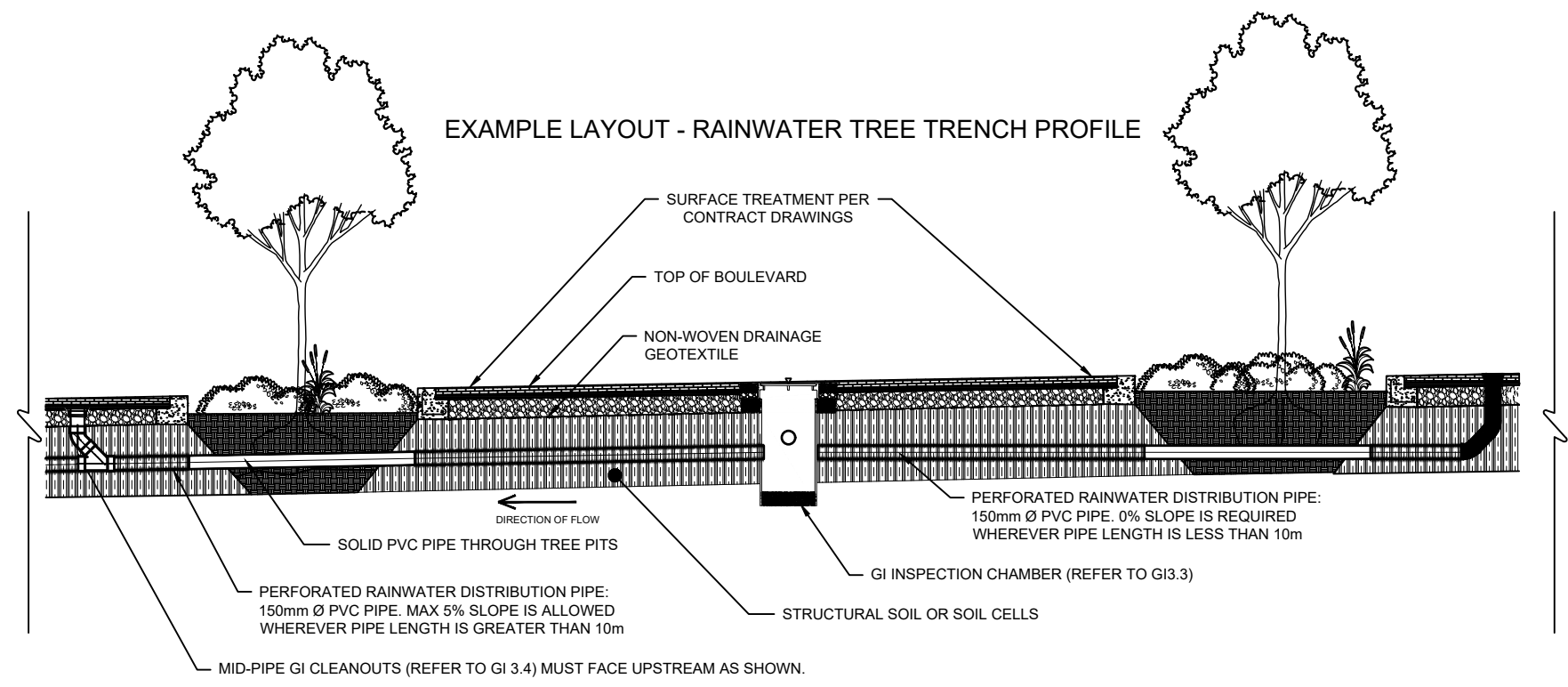

NOTES:

1. TREE TRENCH SEGMENTS MAY BE CONNECTED IN SERIES TO IMPROVE WATER DISTRIBUTION AND DRAINAGE. S-BENDS CAN BE USED TO CONNECT SEGMENTS AT DIFFERENT ELEVATIONS TO ENSURE DISTRIBUTION PIPES STAY AT 0%.
2. UNDERDRAIN PIPES SHOULD BE PLACED AT A MINIMUM OF 0.30m FROM THE BOTTOM OF THE SURFACE TREATMENT.
3. DRAINAGE MAY BE DIRECTED TO THE SOIL MEDIUM THROUGH CURB CUTS OR CATCHBASINS AND DRAINAGE PIPES.
4. STRUCTURAL SOIL MUST BE FULLY COMPACTED PRIOR TO SURFACE TREATMENT INSTALLATION
5. ARRANGEMENTS OF INSPECTION CHAMBERS, OFFSET CBs AND TREE PITS MAY VARY.
6. EXTENT OF STRUCTURAL SOIL OR SOIL CELLS MAY VARY.
7. TREES IN RAINWATER TREE TRENCHES SHALL HAVE THE APPROPRIATE SOIL VOLUME AS OUTLINED IN THE CITY OF VANCOUVER URBAN FOREST STRATEGY
8. RAINWATER TREE TRENCHES SHALL CONTAIN THE SOIL VOLUME NECESSARY TO SUPPORT THE NUMBER OF TREES IN A CONTIGUOUS TRENCH, AS OUTLINES IN THE CITY OF VANCOUVER URBAN FOREST STRATEGY.

RAINWATER TREE TRENCHES
RAINWATER TREE TRENCH LAYOUT

ISSUE DATE: FEBRUARY 2026
APPROVED BY: N. MEAD-FOX

REV.	REVISION DATE	APPROVED

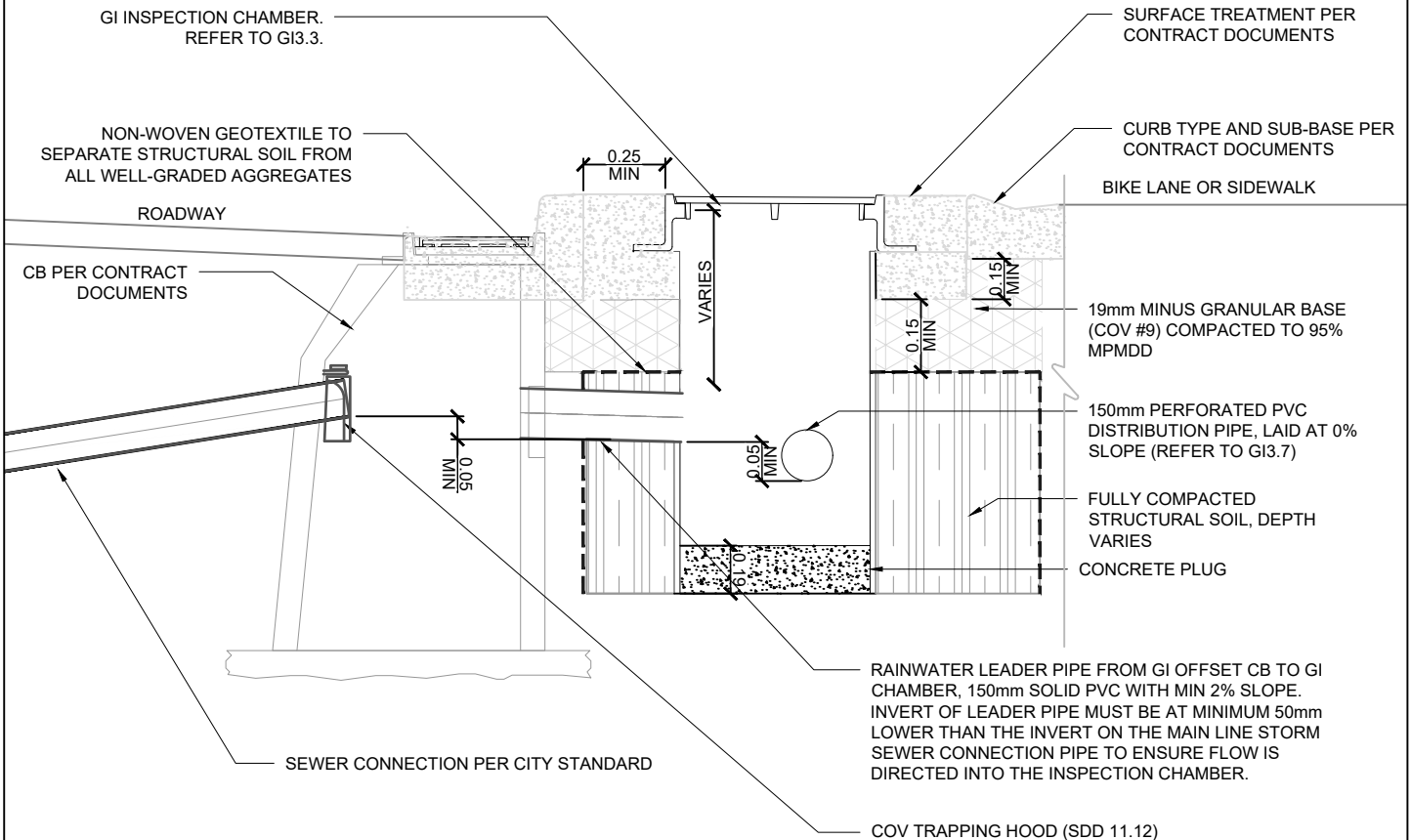

NOTES:

1. CONNECTIONS TO INSPECTION CHAMBER AND LOCATION OF OFFSET CBs MAY VARY DEPENDING ON SITE CONDITIONS
2. OFFSET CBs MAY REPLACE STANDARD CBs
3. CBs MAY BE PLACED ON ONLY ONE SIDE OF TREE TRENCH OR ON BOTH SIDES AS SHOWN
4. INVERT OF CONNECTION TO MAIN LINE CB MUST BE AT MINIMUM 150mm ABOVE THE DISTRIBUTION PIPE INVERT
5. STRUCTURAL SOIL SHALL NOT BE PLACED UNDER ROAD CURBS
6. 6.0m VERTICAL CLEARANCE OVER ALL INSPECTION CHAMBERS IS PREFERRED FOR CLEANOUT ACCESS.

REV.	REVISION DATE	APPROVED

RAINWATER TREE TRENCHES
RTT INSPECTION CHAMBER

ISSUE DATE: FEBRUARY 2026
APPROVED BY: N. MEAD-FOX

**STRUCTURAL SOIL UNDER CONCRETE SIDEWALK
ADJACENT TO VEGETATED RAINWATER TREE TRENCH**

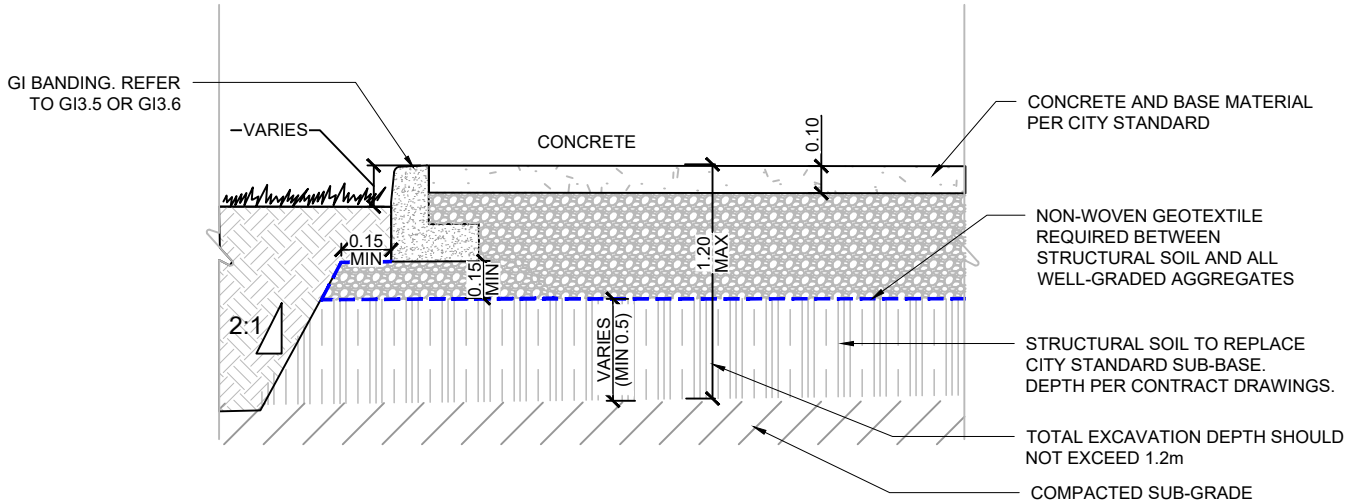

**STRUCTURAL SOIL UNDER ASPHALT BOULEVARD
ADJACENT TO VEGETATED RAINWATER TREE TRENCH**

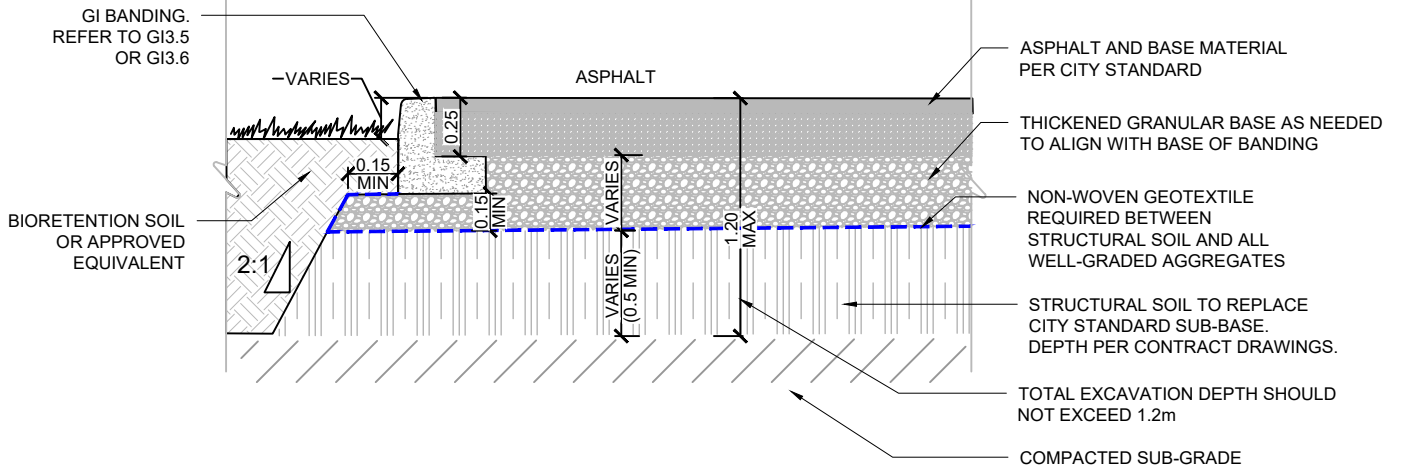

REV.	REVISION DATE	APPROVED

**RAINWATER TREE TRENCHES
STRUCTURAL SOIL ADJACENT TO RTT**

ISSUE DATE: FEBRUARY 2026

APPROVED BY: N. MEAD-FOX

PLAN

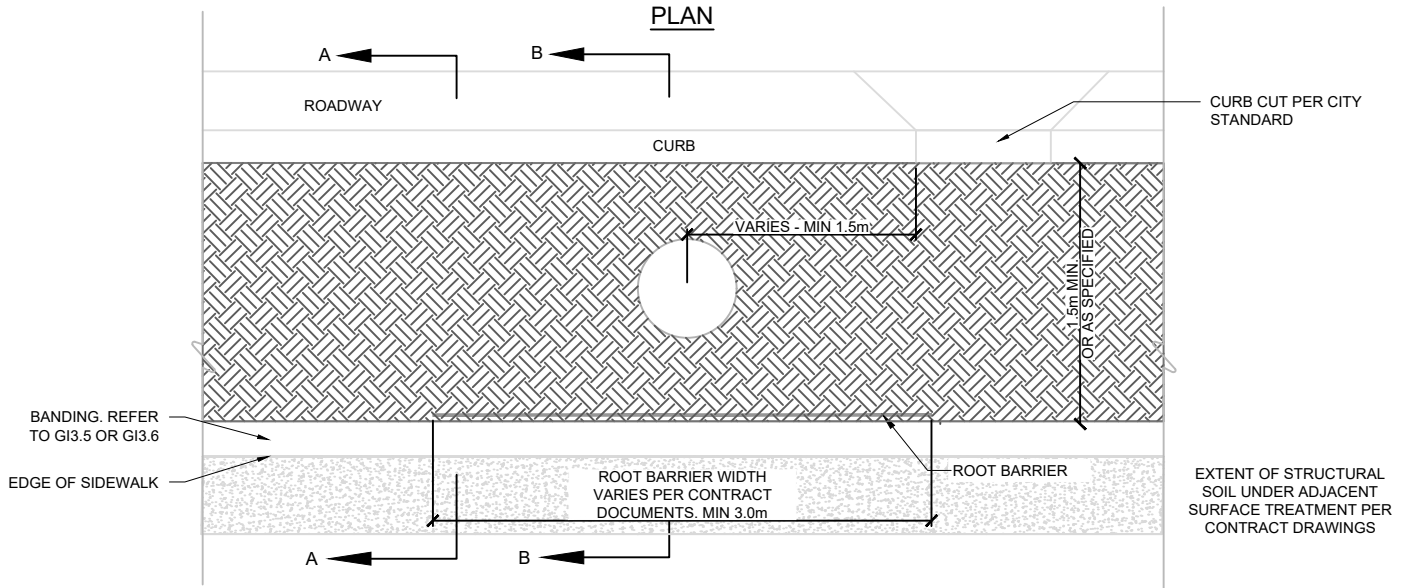

SECTION A-A

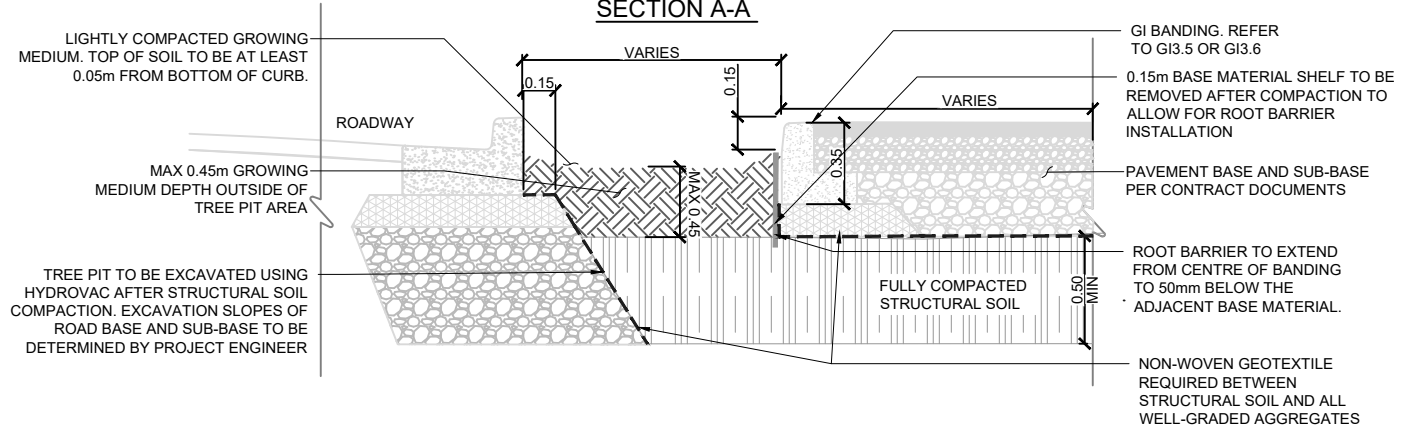

SECTION B-B

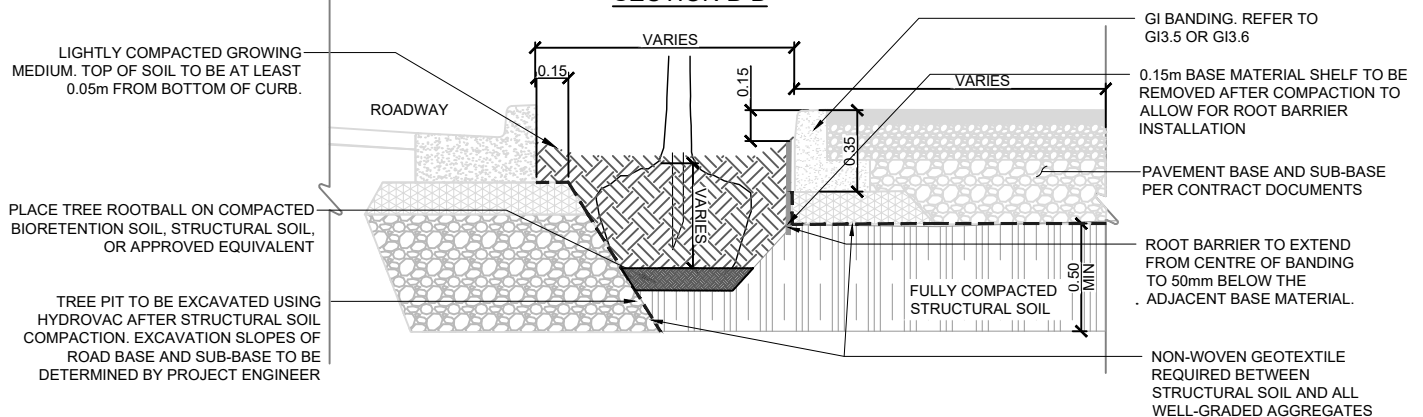

NOTES:

1. PREFERRED GROWING MEDIUM DEPTH FOR GI SYSTEMS IS 450mm. A GROWING MEDIUM DEPTH LESS THAN 450mm MUST BE APPROVED BY THE PROJECT ENGINEER.
2. STRUCTURAL SOIL DEPTH SHOULD RANGE FROM 0.45m TO 1.00m
3. STRUCTURAL SOIL OR SOIL CELLS UNDERNEATH SIDEWALKS OR BIKE LANES REQUIRE STREETS REVIEW AND APPROVAL.
4. CROSS-SLOPE OF TREE TRENCH AND ADJACENT PAVED SURFACES MAY VARY DEPENDING ON SITE CONDITIONS
5. ROOT BARRIERS SHALL BE INSTALLED IMMEDIATELY ABUTTING THE CONCRETE SIDEWALK AND EXTEND 5cm ABOVE BOTTOM OF BANDING
6. TREE PIT TO BE EXCAVATED USING HYDROVAC AFTER STRUCTURAL SOIL COMPACTION. WHERE APPLICABLE, INTERFACE BETWEEN CURB SUB-BASE AND STRUCTURAL SOIL TO BE 2V:1H

REV.	REVISION DATE	APPROVED

RAINWATER TREE TRENCHES
GI SWALE BOULEVARD WITH STREET TREES

ISSUE DATE: FEBRUARY 2026
APPROVED BY: N. MEAD-FOX

PLAN

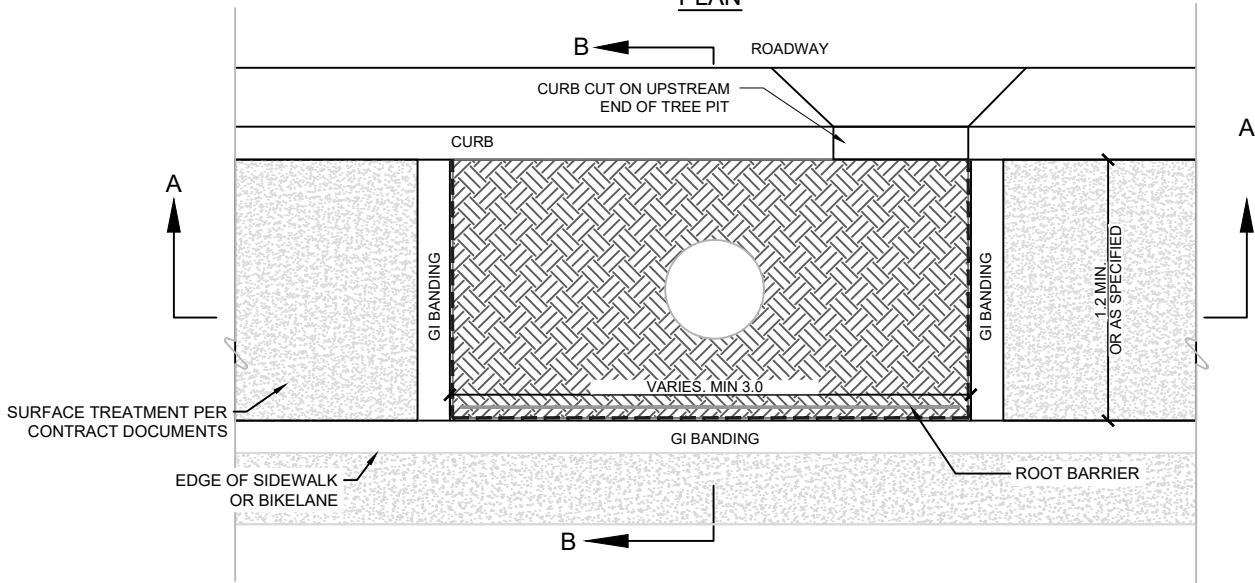

SECTION A-A

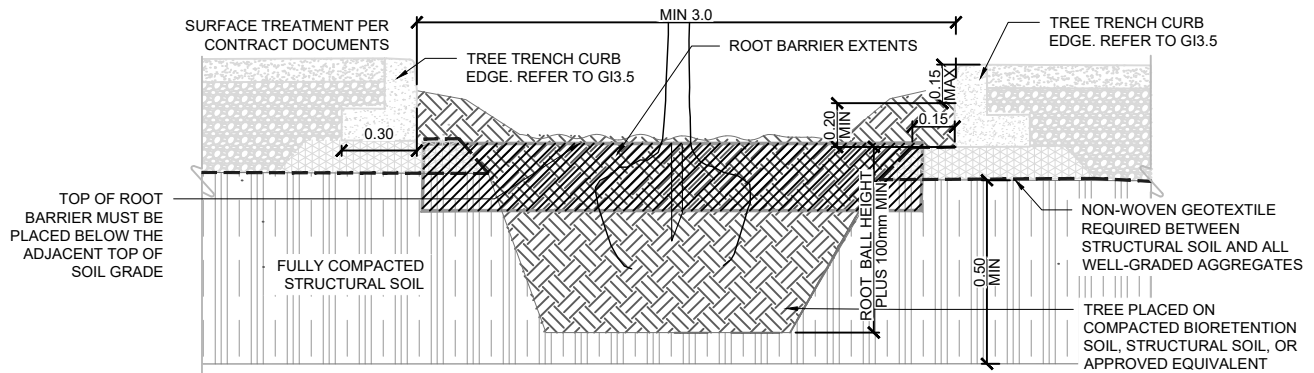

SECTION B-B

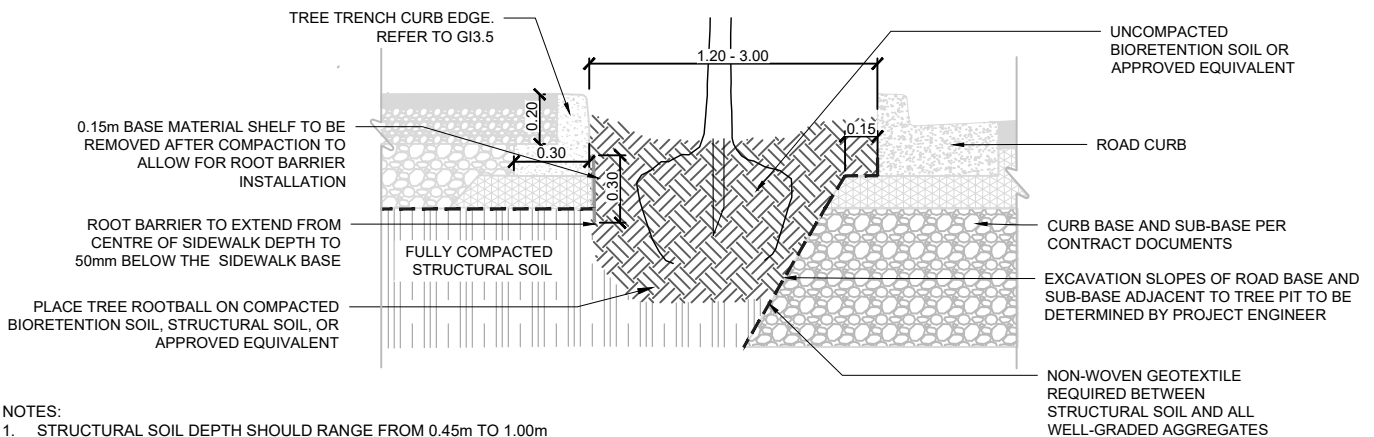

NOTES:

1. STRUCTURAL SOIL DEPTH SHOULD RANGE FROM 0.45m TO 1.00m
2. STRUCTURAL SOIL OR SOIL CELLS UNDERNEATH SIDEWALKS OR BIKE LANES REQUIRE STREETS REVIEW AND APPROVAL.
3. CROSS-SLOPE OF TREE TRENCH AND ADJACENT PAVED SURFACES MAY VARY DEPENDING ON SITE CONDITIONS
4. ROOT BARRIERS SHALL BE INSTALLED IMMEDIATELY ABUTTING THE CONCRETE SIDEWALK AND EXTEND AT MINIMUM 5cm ABOVE BOTTOM OF BANDING AND 5cm BELOW THE SIDEWALK BASE MATERIAL
5. AFTER TREE PIT EXCAVATION, SLOPES AT INTERFACE BETWEEN CURB SUB-BASE AND STRUCTURAL SOIL TO BE 2V:1H UNLESS SPECIFIED OTHERWISE IN CONTRACT DOCUMENTS

RAINWATER TREE TRENCHES
GI TREE PIT WITH STRUCTURAL SOIL

ISSUE DATE: FEBRUARY 2026

APPROVED BY: N. MEAD-FOX

REV.	REVISION DATE	APPROVED

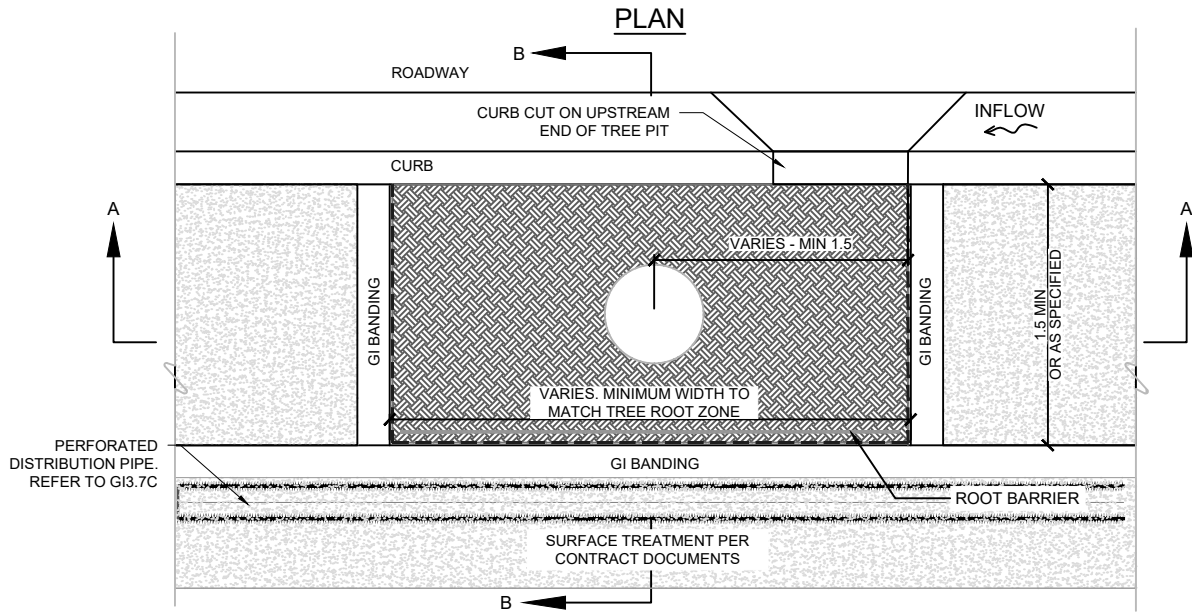

SECTION A-A

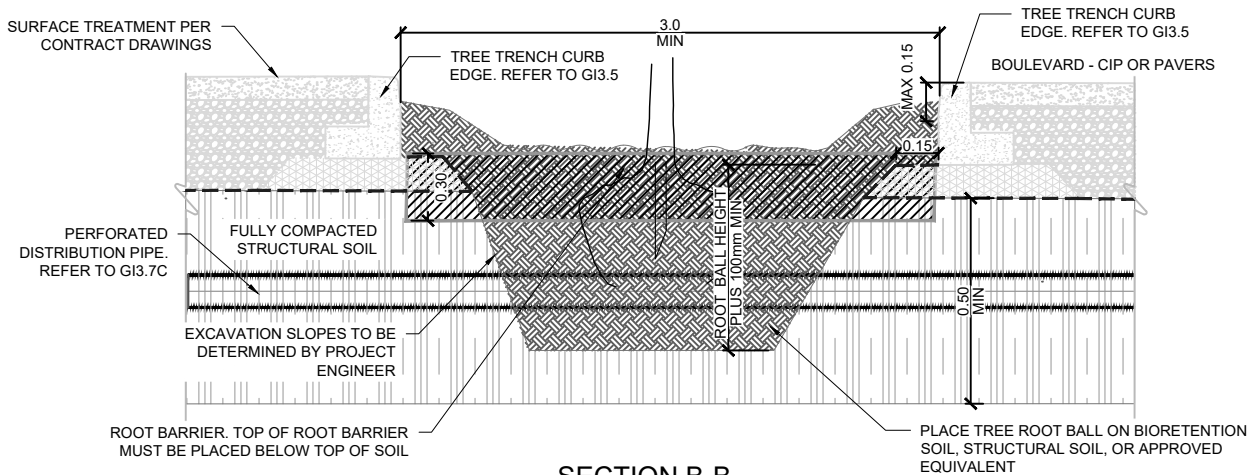

SECTION B-B

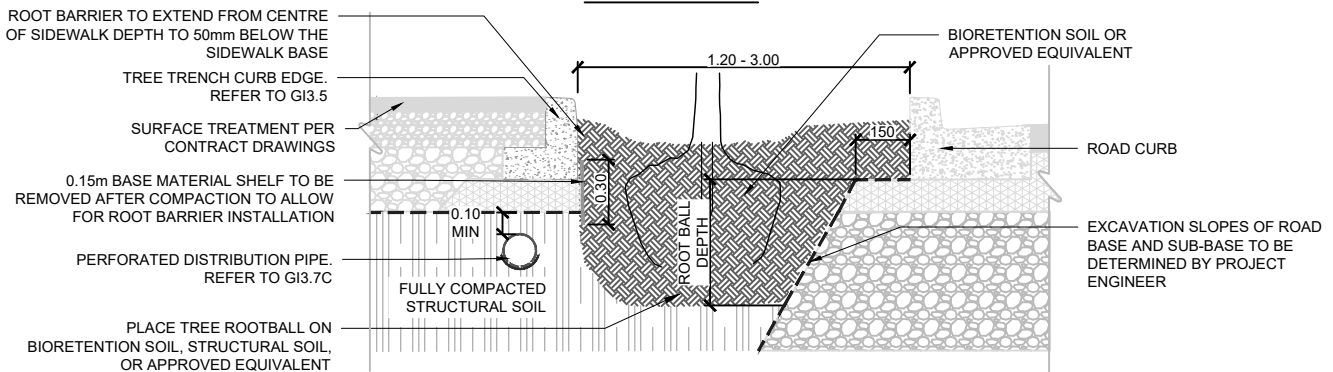

NOTES:

1. STRUCTURAL SOIL DEPTH SHOULD RANGE FROM 0.45m TO 1.00m
2. STRUCTURAL SOIL OR SOIL CELLS UNDERNEATH SIDEWALKS OR BIKE LANES REQUIRE STREETS REVIEW AND APPROVAL.
3. CROSS-SLOPE OF TREE TRENCH AND ADJACENT PAVED SURFACES MAY VARY DEPENDING ON SITE CONDITIONS
4. ROOT BARRIERS SHALL BE INSTALLED IMMEDIATELY ABUTTING THE CONCRETE SIDEWALK AND EXTEND AT MINIMUM 5cm ABOVE BOTTOM OF BANDING AND 5cm BELOW THE SIDEWALK BASE MATERIAL
5. AFTER TREE PIT EXCAVATION, SLOPES AT INTERFACE BETWEEN CURB SUB-BASE AND STRUCTURAL SOIL TO BE 2V:1H UNLESS SPECIFIED OTHERWISE IN CONTRACT DOCUMENTS

REV.	REVISION DATE	APPROVED

RAINWATER TREE TRENCHES
GI TREE PIT WITH DISTRIBUTION PIPE

ISSUE DATE: FEBRUARY 2026
APPROVED BY: N. MEAD-FOX

RAINWATER TREE TRENCH CROSS-SECTION WITH PAVED BOULEVARD

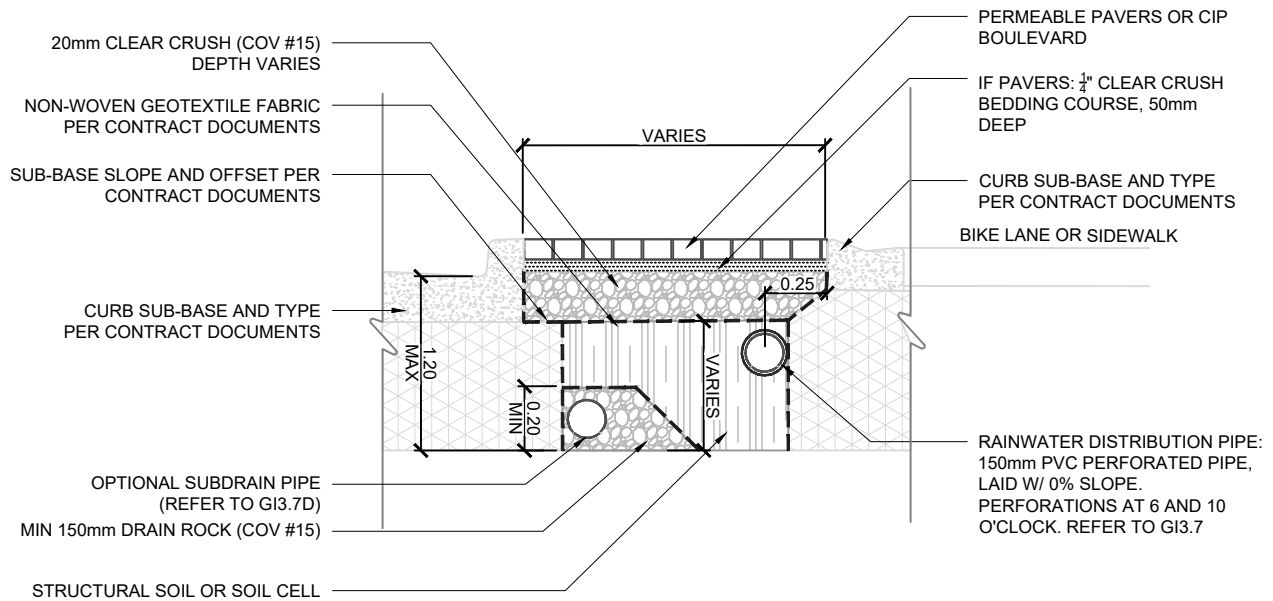

RAINWATER TREE TRENCH CROSS-SECTION WITH PAVERS AND STRUCTURAL SOIL EXTENSION

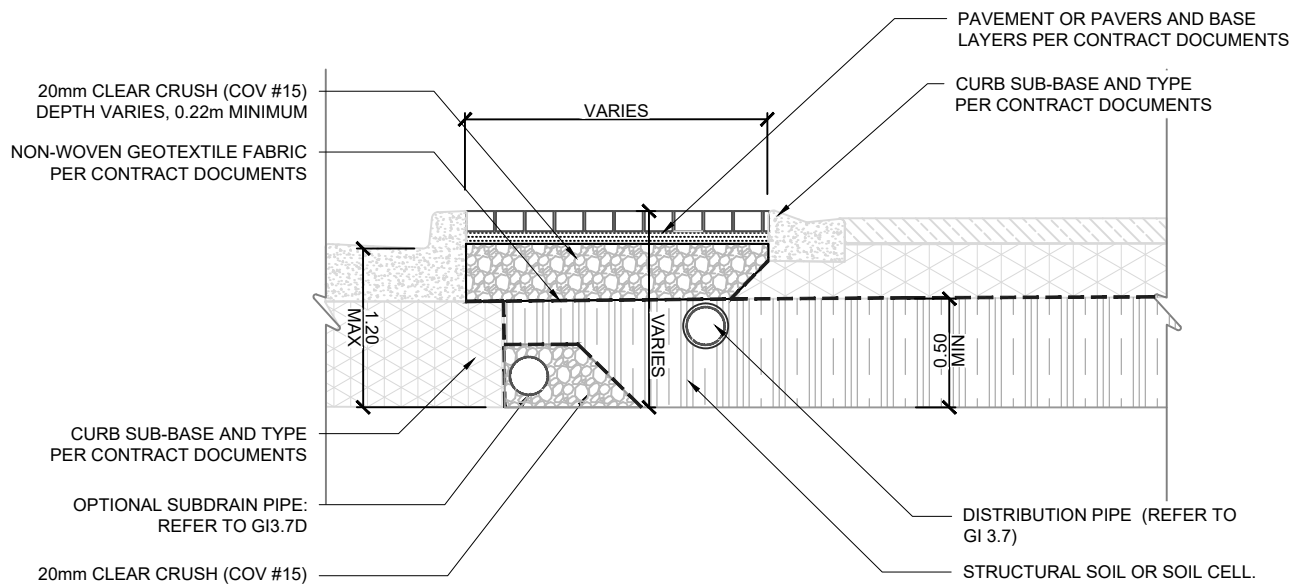

NOTES:

1. STRUCTURAL SOIL OR SOIL CELLS UNDERNEATH SIDEWALKS OR BIKE LANES REQUIRE STREETS REVIEW AND APPROVAL.
2. CROSS-SLOPE OF TREE TRENCH AND ADJACENT PAVED SURFACES MAY VARY DEPENDING ON SITE CONDITIONS
3. VERTICAL EDGE SHOULD ONLY BE ALLOWED DURING SIMULTANEOUS ROAD CONSTRUCTION WHEN THE CURB BASE AND SUB-BASE CAN BE INSTALLED IN LIFTS DIRECTLY ADJACENT TO THE STRUCTURAL SOIL.
4. ACCEPTABILITY OF VERTICAL EDGE CONDITIONS IS DEPENDENT ON A SUPPORTIVE GEOTECHNICAL SITE ASSESSMENT.

REV.	REVISION DATE	APPROVED

RAINWATER TREE TRENCHES
VERTICAL EDGE RTT CROSS-SECTIONS

ISSUE DATE: FEBRUARY 2026

APPROVED BY: N. MEAD-FOX

INFILTRATION SYSTEMS DESIGN NOTES AND GUIDANCE

PURPOSE:

INFILTRATION SYSTEMS RETAIN RAINWATER RUNOFF BY PROVIDING SURFACE STORAGE, SUBSURFACE STORAGE AND INFILTRATION INTO NATIVE SOIL. THE STORAGE IN INFILTRATION SYSTEMS CAN ALSO REDUCE THE PEAK FLOW ENTERING SEWERS AND REMOVE RAINWATER FROM ENTERING SEWERS.

DESIGNER NOTES & GUIDELINES:

1. THE DESIGNER MUST ADAPT PLAN AND SECTION DRAWINGS TO ADDRESS SITE-SPECIFIC CONDITIONS.
2. SYSTEM SURFACE AREA, PONDING DEPTH, SOIL DEPTH, AND AGGREGATE STORAGE DEPTH MUST BE SIZED TO MEET PROJECT HYDROLOGIC PERFORMANCE GOALS.
3. PONDING AND SYSTEM DRAWDOWN TIME (i.e., TIME FOR MAXIMUM SURFACE PONDING TO DRAIN THROUGH THE SYSTEM AFTER THE END OF A STORM) RECOMMENDATIONS:
 - 24 HOUR MAXIMUM SURFACE PONDING DRAWDOWN
 - 72 HOUR MAXIMUM DRAWDOWN FOR RTT SOIL AND AGGREGATE STORAGE
4. INFILTRATION SYSTEMS MAY BE DESIGNED USING AGGREGATE STORAGE OR PROPRIETARY STORAGE SYSTEMS. ALL PROPOSED PRODUCTS FOR USE IN RIGHT-OF-WAYS MUST MEET CITY OF VANCOUVER SPECIFICATIONS REGARDING LOADING CAPACITY OF RIGHT-OF-WAY INFRASTRUCTURE.
5. WHEN FACILITY CONSTRUCTION IMPACTS EXISTING SIDEWALK, ALL SAW CUTS MUST ADHERE TO CITY OF VANCOUVER REQUIREMENTS. SAW CUTS SHOULD BE ALONG SCORE LINES AND ANY DISTURBED SIDEWALK PANELS SHOULD BE REPLACED IN THEIR ENTIRETY.
6. GI FACILITIES IN PUBLIC RIGHT OF WAY SHALL BE DESIGNED WITH A SAFE, DESIGNATED OVERLAND FLOW PATH TO THE STREET IN THE EVENT THAT THE OVERFLOW STRUCTURE IS OBSTRUCTED OR CLOGGED. THIS FLOW PATH SHOULD BE REFLECTED IN SITE GRADING AND LABELED ON GI DRAWINGS.
7. THE DESIGNER MUST EVALUATE UTILITY SURVEYS FOR POTENTIAL UTILITY CROSSINGS OR CONFLICTS.
8. MINIMUM UTILITY SETBACKS AND PROTECTION MEASURES MUST CONFORM TO CURRENT CITY OF VANCOUVER ASSET PROTECTION STANDARDS AND OTHER UTILITY PROVIDER REQUIREMENTS.
9. DESIGN OF SUBSURFACE INFILTRATION FACILITIES MUST ALWAYS BE BASED ON SITE-SPECIFIC GEOTECHNICAL ANALYSIS AND MUST CONSIDER THE POTENTIAL IMPACT OF INCREASED INFILTRATION ON SURROUNDING INFRASTRUCTURE.

RELATED DETAILS	
EDGE TREATMENTS:	GI 3.5 - GI 3.6
INLETS:	GI 2.1 - GI 2.5
UNDERDRAINS:	GI 3.7
MONITORING WELL	GI 3.2
CLEANOUTS	GI 3.4
INSPECTION CHAMBERS	GI 3.3
CATCHBASINS	GI 3.1 - GI 3.8

RELATED SPECIFICATIONS	COV SPEC NO.
- DRY WELLS	***
- INFILTRATION TRENCHES	***
- AGGREGATES AND GRANULAR MATERIALS	31 05 17S
- DRAINAGE FABRIC	31 32 19
- ENGINEERED SOIL	32 91 22S

***TEMPLATE ONLY. AVAILABLE UPON REQUEST FROM THE GII BRANCH.

LAYOUT REQUIREMENTS:

1. REFER TO THE CITY OF VANCOUVER ACCESSIBILITY STRATEGY, STANDARD DRAWINGS AND CONSTRUCTION SPECIFICATIONS FOR RIGHT-OF-WAY, PARKING SPACE, AND ACCESSIBLE PATH REQUIREMENTS.
2. LOCATE CURB CUTS AND GUTTER MODIFICATIONS TO AVOID CONFLICTS WITH ACCESSIBILITY REQUIREMENTS (E.G., LOCATE OUTSIDE OF CROSSWALKS OR PARKING LAYBYS)

DESIGNER CHECKLIST (MUST SPECIFY, AS APPLICABLE):

- SYSTEM WIDTH AND LENGTH
- DEPTH OF PONDING (IF APPLICABLE)
- DEPTH OF SYSTEM
- DEPTH AND TYPE OF AGGREGATE STORAGE
- SURFACE ELEVATION AT UPSLOPE AND DOWNSLOPE ENDS OF FACILITY
- DIMENSIONS AND DISTANCE TO EVERY MUNICIPAL SERVICE/UTILITY WITHIN 10m OF THE FACILITY
- ELEVATIONS OF EVERY INLET, OUTLET, STRUCTURE RIM AND PIPE INVERT
- TYPE AND DESIGN OF COMPONENTS (E.G., EDGE TREATMENTS, INLETS/GUTTER MODIFICATIONS, UTILITY CROSSINGS, LINER, AND PLANTING DETAILS)

REV.	REVISION DATE	APPROVED

INFILTRATION SYSTEMS
DESIGN NOTES AND GUIDANCE

ISSUE DATE: FEBRUARY 2026
APPROVED BY: N. MEAD-FOX

SUB-SURFACE INFILTRATION SYSTEM DRAWING DESCRIPTIONS

GI6.0A	INFILTRATION SYSTEM DESIGN NOTES	THE SUB-SURFACE INFILTRATION SYSTEMS DESIGN NOTES PROVIDE GUIDANCE TO DESIGNERS ON HOW TO USE AND ADAPT THE TEMPLATE STANDARDS IN THIS SECTION.
GI6.0B	INFILTRATION SYSTEM DRAWING DESCRIPTIONS	THIS DRAWING DESCRIBES THE PURPOSE AND INTENDED USE OF EACH SUB-SURFACE INFILTRATION SYSTEM DRAWING.
GI6.1	BOULEVARD INFILTRATION TRENCH	THIS STANDARD DEPICTS AN INFILTRATION TRENCH BENEATH A BOULEVARD AREA. IT IS FUNCTIONALLY SIMILAR TO A ROADWAY INFILTRATION TRENCH BUT WITH ADDITIONAL OPTIONS FOR SUBSURFACE AGGREGATE AND IMPERMEABLE LINER USE.
GI6.2	BOULEVARD DRY WELL	DRY WELLS DIRECT ROAD RUNOFF INTO A PERFORATED INSPECTION CHAMBER SURROUNDED BY LOOSE AGGREGATE. THESE SYSTEMS CAN ENCOURAGE INFILTRATION IN AREAS WHERE AN INFILTRATION TRENCH IS INFEASIBLE DUE TO SITE CONSTRAINTS. OVERFLOW FROM DRY WELLS IS DIRECTED INTO CITY SEWERS.
GI6.3	ROADWAY INFILTRATION TRENCH	THIS STANDARD DEPICTS AN INFILTRATION TRENCH BENEATH A PORTION OF ROADWAY DIRECTLY ADJACENT TO A CURB. INFILTRATION TRENCHES ARE FUNCTIONALLY SIMILAR TO TREE TRENCHES BUT ARE DESIGNED UNDER HARDSCAPES. THEY REQUIRE CATCHBASINS TO DIRECT RUNOFF INTO PERFORATED DISTRIBUTION PIPES THAT DRAIN INTO THE VOIDS OF SUBSURFACE AGGREGATE. THE INFILTRATION AREA OF A TREE TRENCH IS OFTEN CONFINED TO MINIMIZE POTENTIAL IMPACTS ON SURROUNDING INFRASTRUCTURE. APPROVAL OF THESE SYSTEMS IS DETERMINED ON A SITE BY SITE BASIS AT THE DISCRETION OF THE CITY ENGINEER.

REV.	REVISION DATE	APPROVED

**INFILTRATION SYSTEMS
DRAWING DESCRIPTIONS**

ISSUE DATE: FEBRUARY 2026
APPROVED BY: N. MEAD-FOX

CONCEPTUAL AXONOMETRIC

REFER TO CITY OF VANCOUVER SIDEWALK LANDSCAPING REFERENCE DRAWINGS AND SPECIFICATIONS FOR ADDITIONAL GUIDANCE ON BOULEVARD SURFACE TREATMENTS

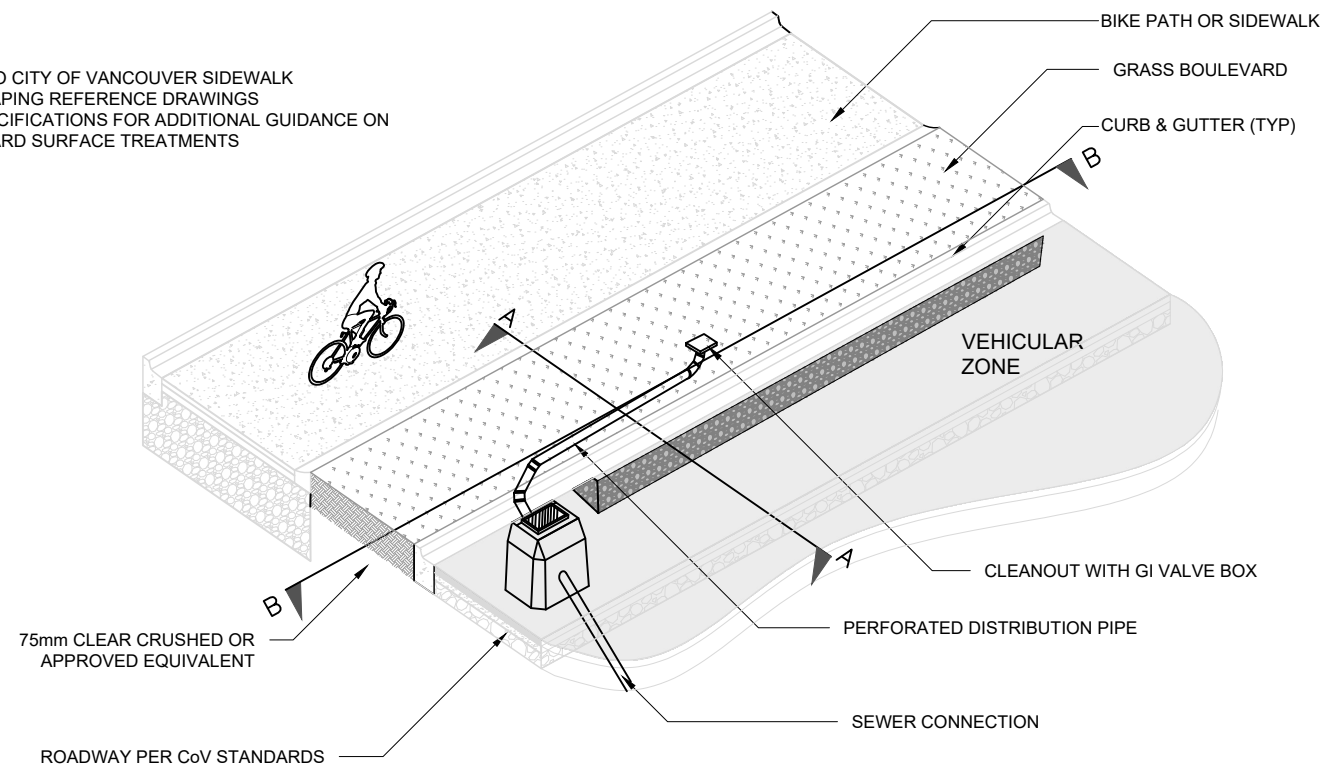

SECTION A-A

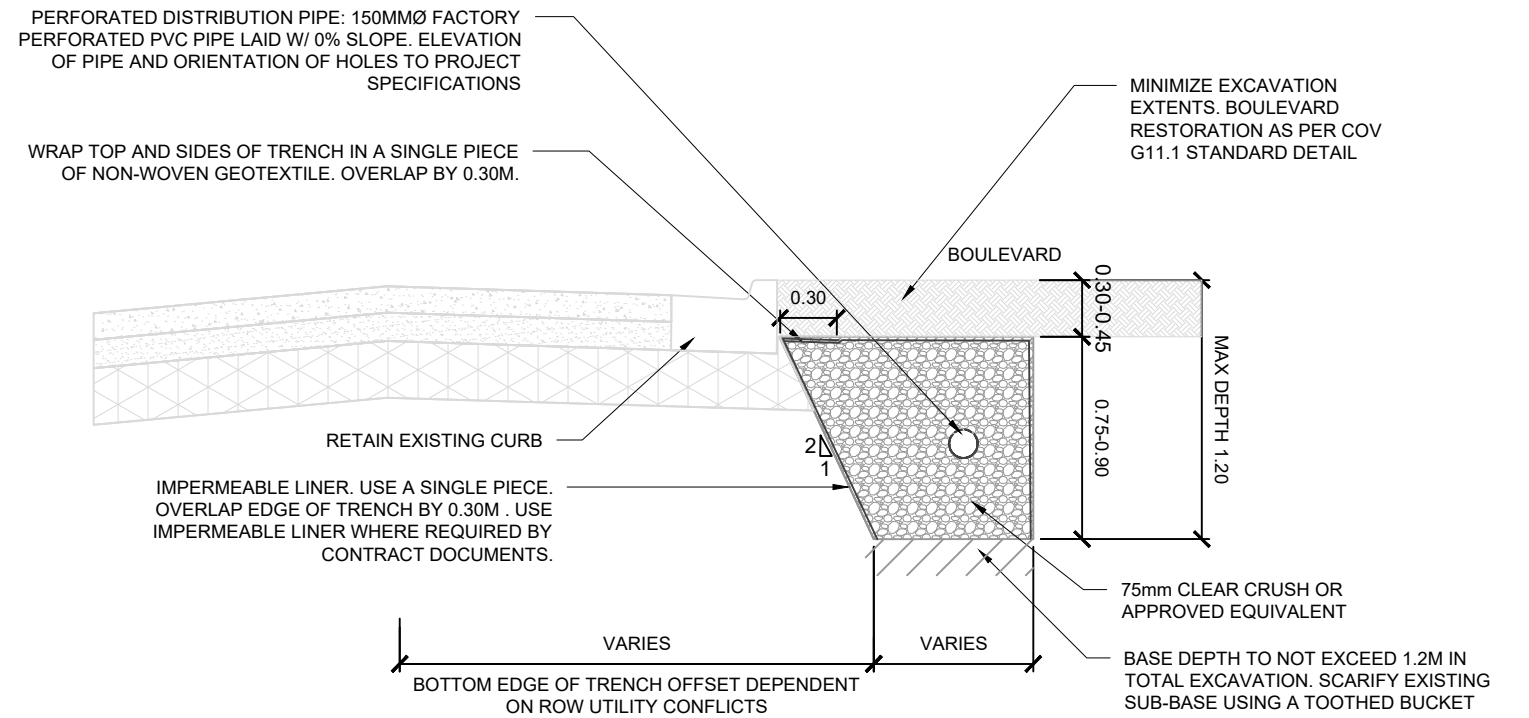

SECTION B-B

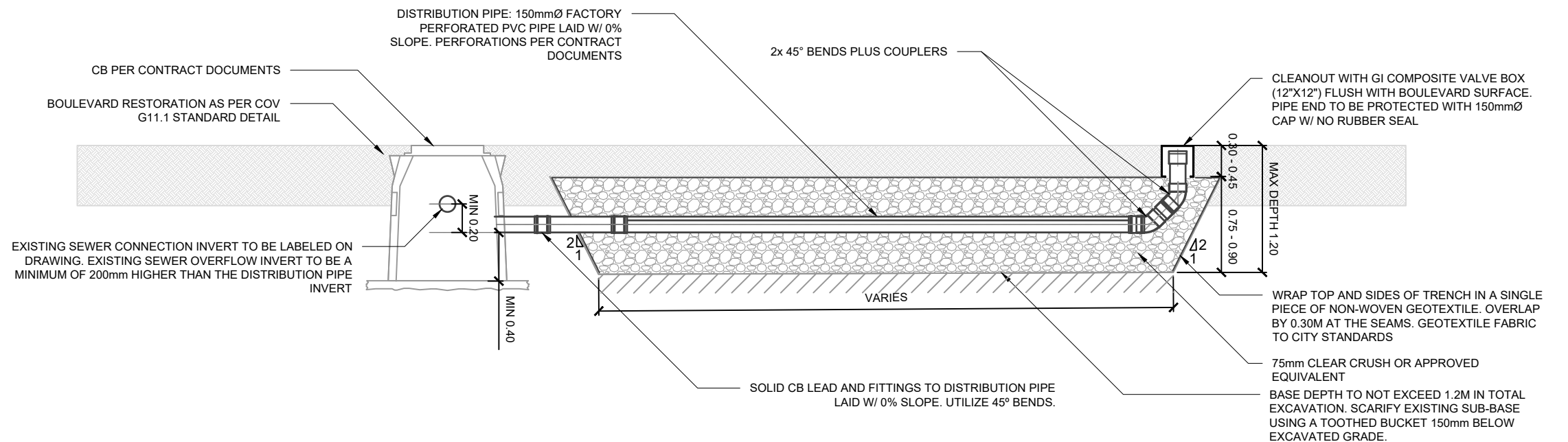

NOTES

1. LABEL AND DISPLAY ALL UTILITIES AND/OR SERVICES THAT CROSS BELOW OR THROUGH THE INFILTRATION TRENCH ALONG WITH THEIR INVERT ELEVATIONS
2. SHOW ALL UTILITY PROTECTION MEASURES AND SETBACKS FOR SERVICES AND/OR UTILITY CONFLICTS
3. ECOWASTE RECYCLED GRANITE (25mm) MAY BE USED AS AN ALTERNATIVE FOR CoV #15 IN BOULEVARD INFILTRATION SYSTEMS
4. PRE-SURVEY OF THE EXISTING CATCH BASIN (CB) CONDITIONS MUST BE CONDUCTED. THE PICTURES OF CBS (INSIDE AND OUTSIDE), WELL ORGANIZED AND CORRELATED WITH THE CB LOCATION, ARE SUFFICIENT.
5. CORE OPENING IN THE EXISTING CB WALL TO SUIT PVC PERFORATED PIPE CONNECTION. GROUT ANNULAR OPENING AROUND THE PIPE WITH NON-SHRINK GROUT.
6. COV REPRESENTATIVE (SEWER MAINTENANCE INSPECTOR) SHALL INSPECT AND APPROVE THE CONNECTION PRIOR TO THE PIPE BEING BURIED. CONTACT SEWERS AT 604-871-6170 TO ARRANGE FOR INSPECTION. PROVIDE AT LEAST 48 HOURS NOTIFICATION.

INFILTRATION SYSTEMS
BOULEVARD INFILTRATION TRENCH

ISSUE DATE: FEBRUARY 2026
APPROVED BY: N. MEAD-FOX

REV.	REVISION DATE	APPROVED

CONCEPTUAL AXONOMETRIC

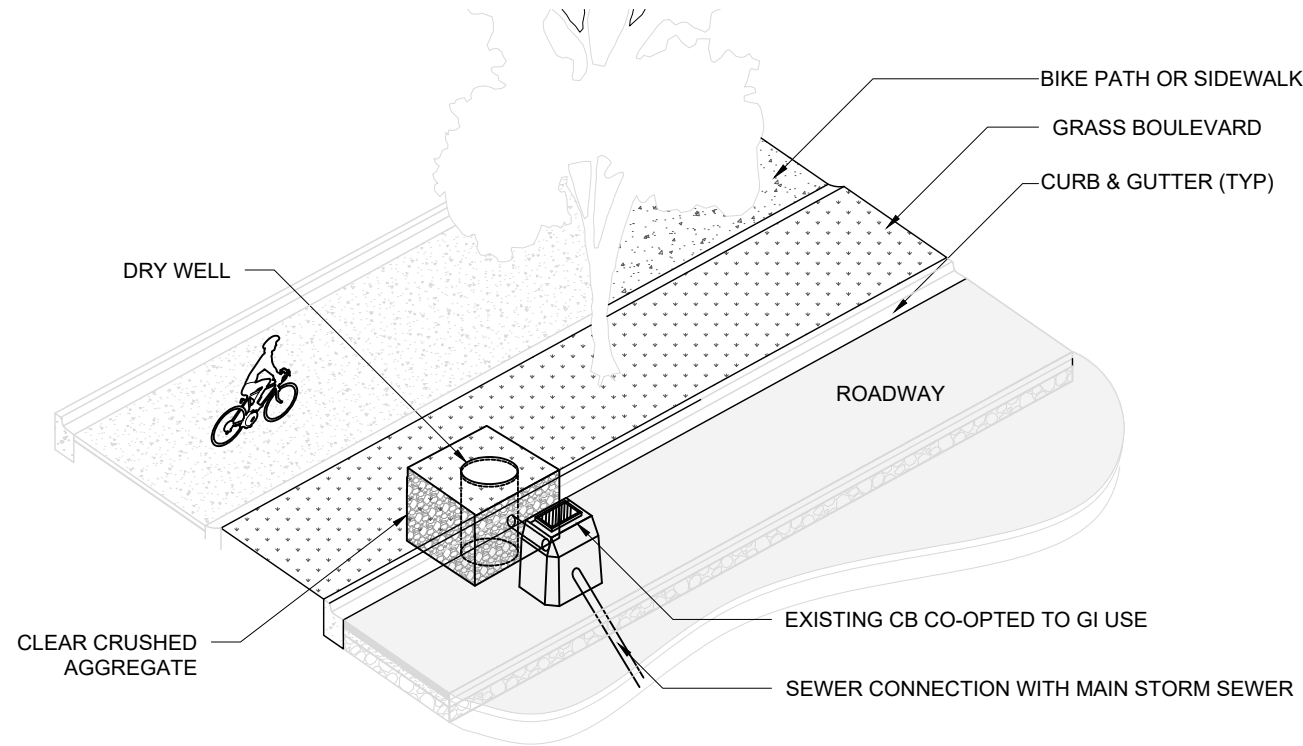

PLAN VIEW

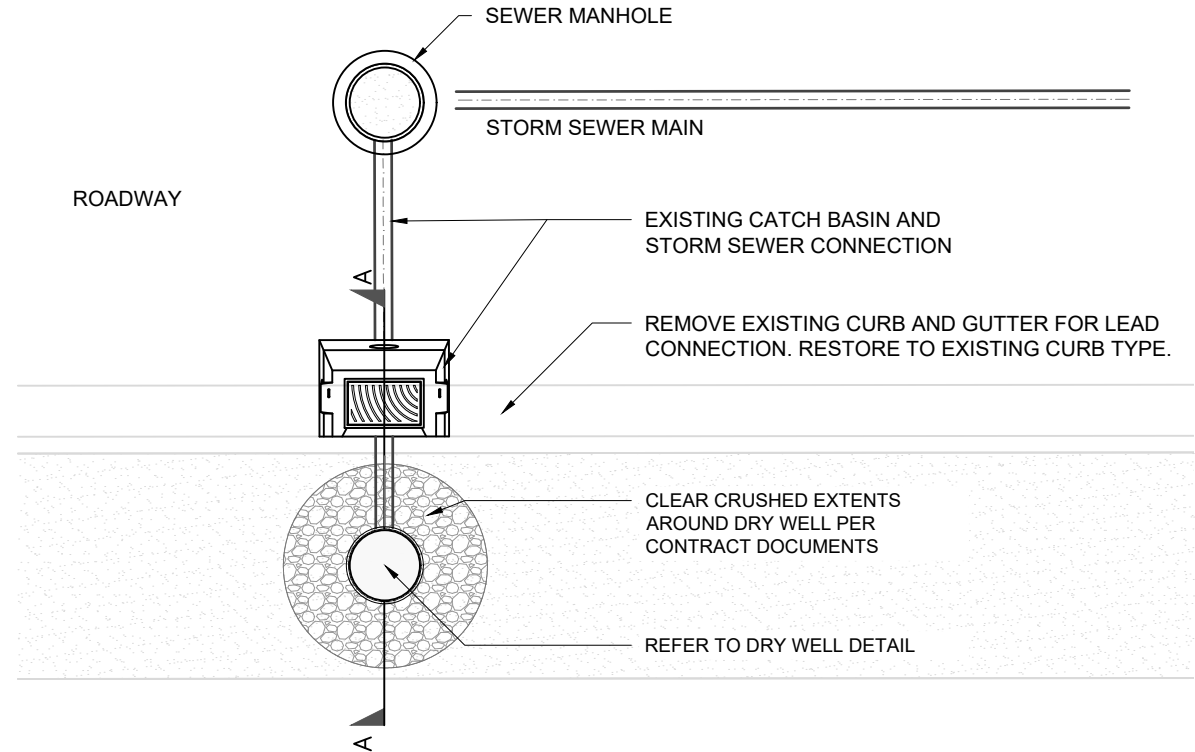

NOTES

1. LABEL AND DISPLAY ALL UTILITIES AND/OR SERVICES THAT CROSS BELOW OR THROUGH THE INFILTRATION TRENCH ALONG WITH THEIR INVERT ELEVATIONS
2. SHOW ALL UTILITY PROTECTION MEASURES AND SETBACKS FOR SERVICES AND/OR UTILITY CONFLICTS
3. ECOWASTE RECYCLED GRANITE (25mm) MAY BE USED AS AN ALTERNATIVE FOR CoV #15 IN BOULEVARD INFILTRATION SYSTEMS
4. PRE-SURVEY OF THE EXISTING CATCH BASIN (CB) CONDITIONS MUST BE CONDUCTED. THE PICTURES OF CBS (INSIDE AND OUTSIDE), WELL ORGANIZED AND CORRELATED WITH THE CB LOCATION, ARE SUFFICIENT.
5. CORE OPENING IN THE EXISTING CB WALL TO SUIT PVC PERFORATED PIPE CONNECTION. GROUT ANNULAR OPENING AROUND THE PIPE WITH NON-SHRINK GROUT.
6. COV REPRESENTATIVE (SEWER MAINTENANCE INSPECTOR) SHALL INSPECT AND APPROVE THE CONNECTION PRIOR TO THE PIPE BEING BURIED. CONTACT SEWERS AT 604-871-6170 TO ARRANGE FOR INSPECTION. PROVIDE AT LEAST 48 HOURS NOTIFICATION.

SECTION A-A

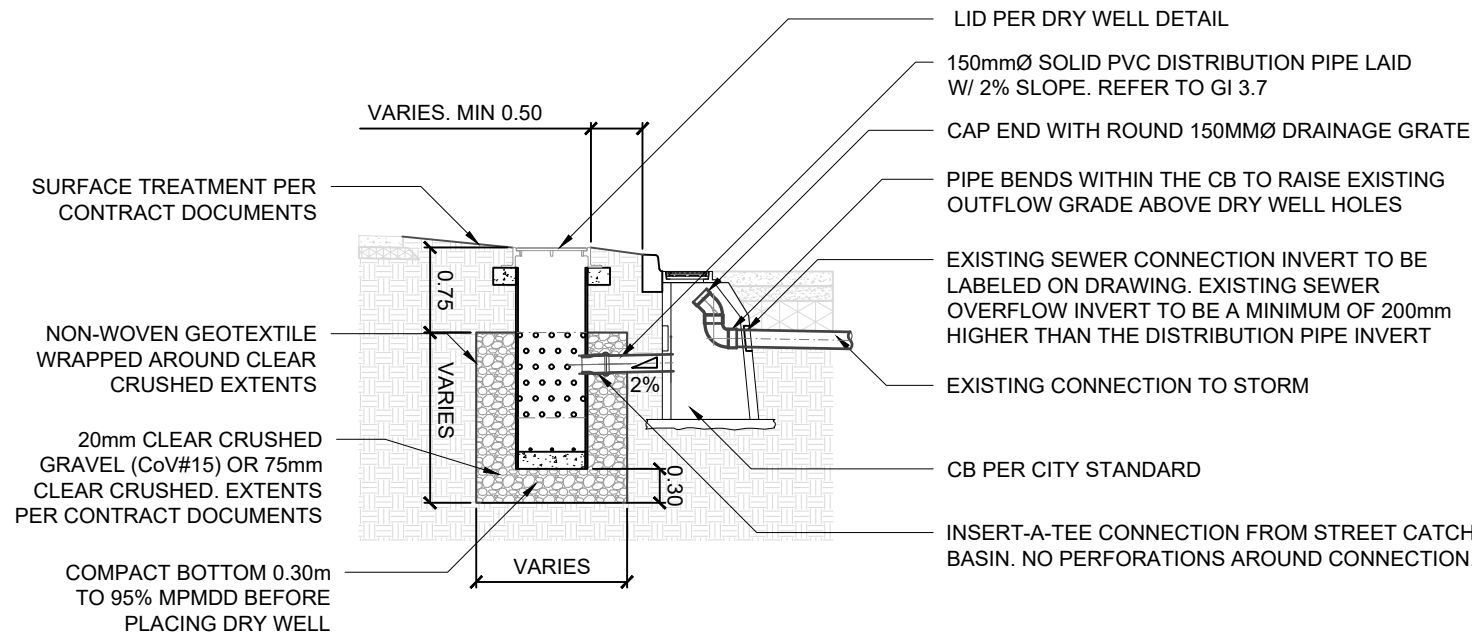

DRY WELL DETAIL

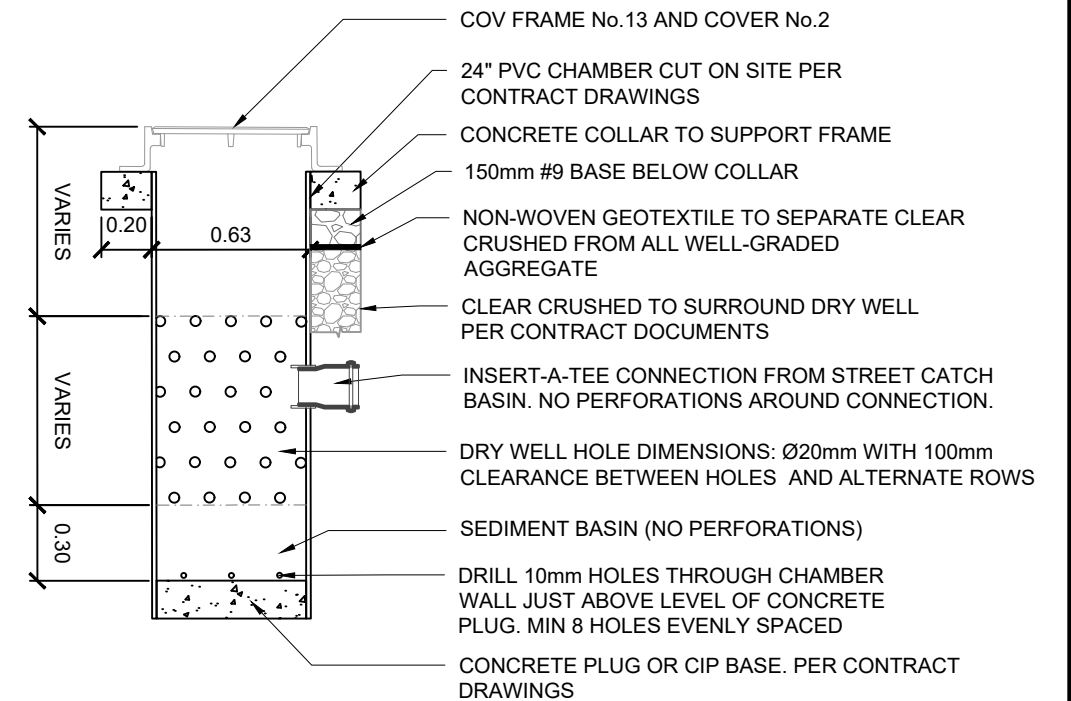

INFILTRATION SYSTEMS
BOULEVARD DRY WELL

ISSUE DATE: FEBRUARY 2026
APPROVED BY: N. MEAD-FOX

REV.	REVISION DATE	APPROVED

CONCEPTUAL AXONOMETRIC

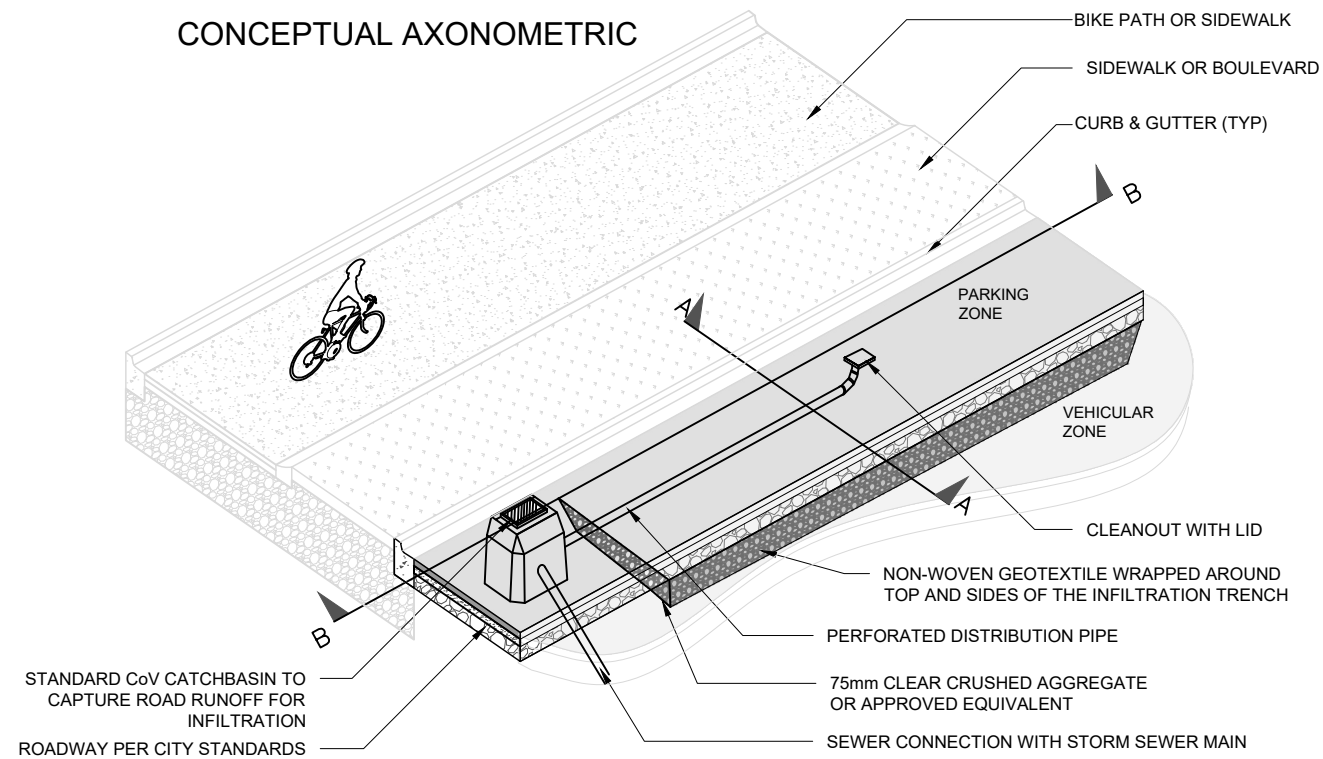

SECTION A-A

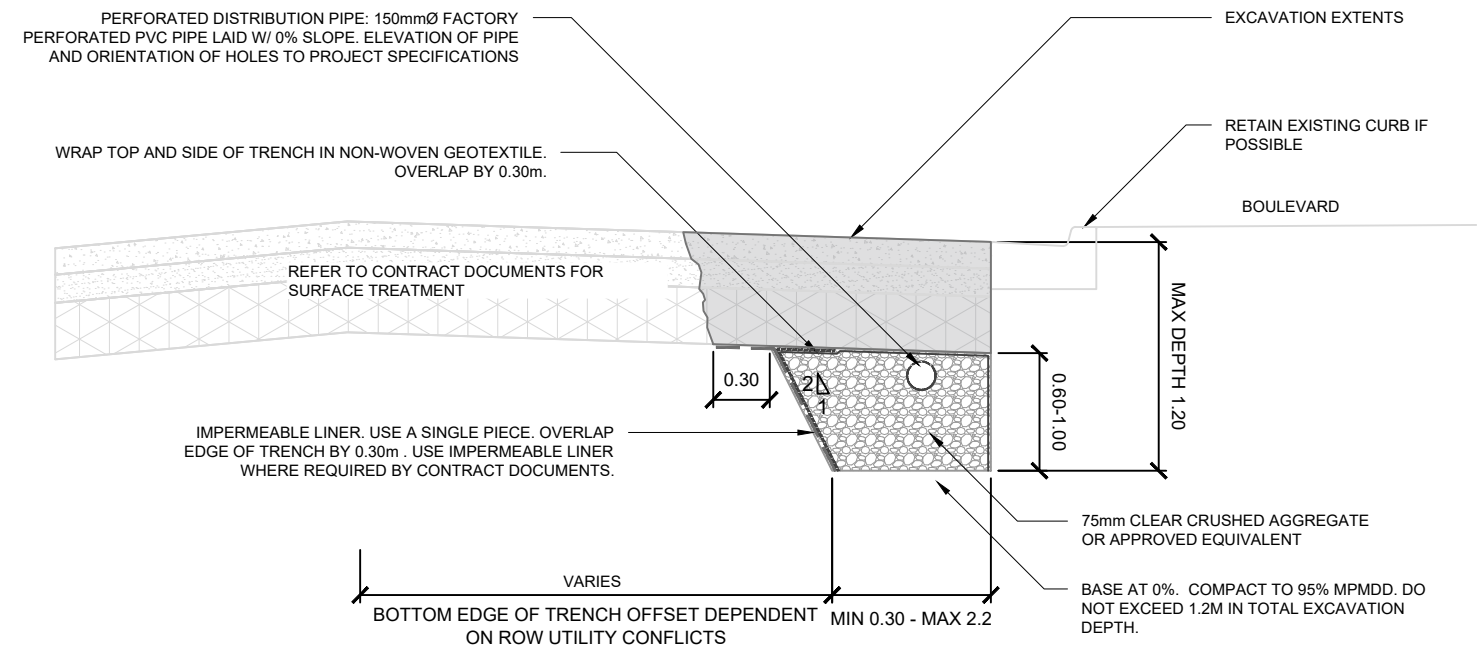

NOTES

1. ROADWAY INFILTRATION TRENCHES ARE APPROVED ON A SITE BY SITE BASIS AND AT THE DISCRETION OF THE CITY ENGINEER
2. LABEL AND DISPLAY ALL UTILITIES AND/OR SERVICES THAT CROSS BELOW OR THROUGH THE INFILTRATION TRENCH ALONG WITH THEIR INVERT ELEVATIONS
3. SHOW ALL UTILITY PROTECTION MEASURES AND SETBACKS FOR SERVICES AND/OR UTILITY CONFLICTS
4. PRE-SURVEY OF THE EXISTING CATCH BASIN (CB) CONDITIONS MUST BE CONDUCTED. THE PICTURES OF CBS (INSIDE AND OUTSIDE), WELL ORGANIZED AND CORRELATED WITH THE CB LOCATION, ARE SUFFICIENT.
5. CORE OPENING IN THE EXISTING CB WALL TO SUIT PVC PERFORATED PIPE CONNECTION. GROUT ANNULAR OPENING AROUND THE PIPE WITH NON-SHRINK GROUT.
6. COV REPRESENTATIVE (SEWER MAINTENANCE INSPECTOR) SHALL INSPECT AND APPROVE THE CONNECTION PRIOR TO THE PIPE BEING BURIED. PROVIDE AT LEAST 48 HOURS NOTIFICATION.
7. ▼ INDICATES THAT AN ELEVATION MUST BE SPECIFIED AT THIS LOCATION ON CONTRACT DRAWINGS

SECTION B-B

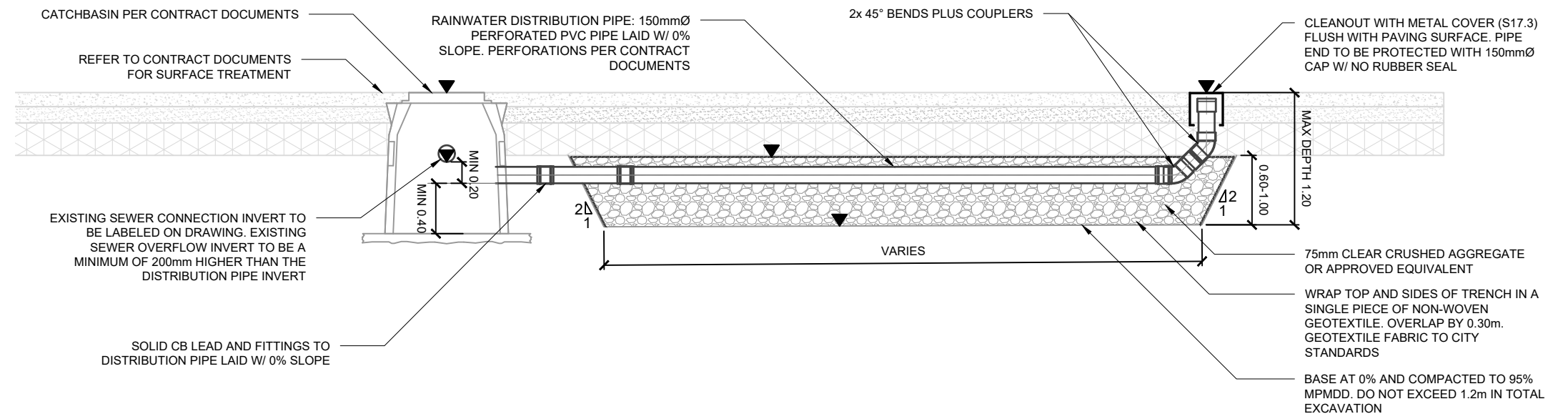

INFILTRATION SYSTEMS
ROADWAY INFILTRATION TRENCH

ISSUE DATE: FEBRUARY 2026
APPROVED BY: N. MEAD-FOX

REV.	REVISION DATE	APPROVED

BIOSWALE DESIGN NOTES AND GUIDANCE

PURPOSE:

BIOSWALE SYSTEMS RETAIN RAINWATER RUNOFF BY PROVIDING SURFACE STORAGE, SUBSURFACE STORAGE AND INFILTRATION INTO NATIVE SOIL. BIOSWALES CAN ALSO REDUCE THE PEAK FLOW ENTERING SEWERS AND REMOVE RAINWATER FROM ENTERING SEWERS. BIOSWALES ARE SIMILAR TO BIORETENTION SYSTEMS BUT CAN PROVIDE SOME SURFACE CONVEYANCE AND ARE GENERALLY EMPLOYED ALONG THE FULL LENGTH OF A ROADWAY. THEY ARE DISTINCT FROM INFILTRATION SYSTEMS BECAUSE THEY INCLUDE SURFACE VEGETATION.

DESIGNER NOTES & GUIDELINES:

- WHENEVER POSSIBLE, ROAD DRAINAGE SHOULD BE ALLOWED TO DRAIN INTO BIOSWALES THROUGH CURB CUTS. WHERE THIS OCCURS, REFER TO GI7.2.
- GI7.1 SHOULD BE USED WHEN NO ROAD DRAINAGE IS DIRECTED TO THE BIOSWALE.
- THE DESIGNER MUST ADAPT PLAN AND SECTION DRAWINGS TO ADDRESS SITE-SPECIFIC CONDITIONS.
- SYSTEM SURFACE AREA, PONDING DEPTH, SOIL DEPTH, AND AGGREGATE STORAGE DEPTH MUST BE SIZED TO MEET PROJECT HYDROLOGIC PERFORMANCE GOALS.
- RECOMMENDATIONS FOR PONDING AND SYSTEM DRAWDOWN TIME (i.e., TIME FOR MAXIMUM SURFACE PONDING TO DRAIN THROUGH THE SYSTEM AFTER THE END OF A STORM) :
 - 24 HOUR MAXIMUM SURFACE PONDING DRAWDOWN
 - 72 HOUR MAXIMUM DRAWDOWN FOR RTT SOIL AND AGGREGATE STORAGE
- BIOSWALE SYSTEMS MAY BE DESIGNED USING AGGREGATE STORAGE OR PROPRIETARY STORAGE SYSTEMS. ALL PROPOSED PRODUCTS FOR USE IN RIGHT-OF-WAYS MUST MEET CITY OF VANCOUVER SPECIFICATIONS REGARDING LOADING CAPACITY OF RIGHT-OF-WAY INFRASTRUCTURE.
- WHEN FACILITY CONSTRUCTION IMPACTS EXISTING SIDEWALK, ALL SAW CUTS MUST ADHERE TO CITY OF VANCOUVER REQUIREMENTS. SAW CUTS SHOULD BE ALONG SCORE LINES AND ANY DISTURBED SIDEWALK PANELS SHOULD BE REPLACED IN THEIR ENTIRETY.
- GI FACILITIES IN PUBLIC RIGHT OF WAY SHALL BE DESIGNED WITH A SAFE, DESIGNATED OVERLAND FLOW PATH TO THE STREET IN THE EVENT THAT THE OVERFLOW STRUCTURE IS OBSTRUCTED OR CLOGGED. THIS FLOW PATH SHOULD BE REFLECTED IN SITE GRADING AND LABELED ON GI DRAWINGS.
- THE DESIGNER MUST EVALUATE UTILITY SURVEYS FOR POTENTIAL UTILITY CROSSINGS OR CONFLICTS.
- MINIMUM UTILITY SETBACKS AND PROTECTION MEASURES MUST CONFORM TO CURRENT CITY OF VANCOUVER ASSET PROTECTION STANDARDS AND OTHER UTILITY PROVIDER REQUIREMENTS.

RELATED DETAILS	
EDGE TREATMENTS	GI 3.5 - GI 3.6
INLETS	GI 2.1 - GI 2.6
UNDERDRAINS:	GI 3.7
CHECK DAMS:	GI 4.7
MONITORING WELL	GI 3.2
CLEANOUTS	GI 3.4
WEIRS AND SEDIMENT PAD	GI 4.5 - GI 4.6
INSPECTION CHAMBERS	GI 3.3
CATCHBASINS	GI 3.1 - GI 3.8

RELATED SPECIFICATIONS	COV SPEC NO.
- BIORETENTION SYSTEMS	***
- BIORETENTION SOIL MIX	***
- AGGREGATES AND GRANULAR MATERIALS	31 05 17
- GEOSYNTHETICS	31 32 19

***TEMPLATE ONLY. AVAILABLE UPON REQUEST FROM THE GII BRANCH.

LAYOUT REQUIREMENTS:

- REFER TO THE CITY OF VANCOUVER ACCESSIBILITY STRATEGY, STANDARD DRAWINGS AND CONSTRUCTION SPECIFICATIONS FOR RIGHT-OF-WAY, PARKING SPACE, AND ACCESSIBLE PATH REQUIREMENTS.
- LOCATE CURB CUTS AND GUTTER MODIFICATIONS TO AVOID CONFLICTS WITH ACCESSIBILITY REQUIREMENTS (E.G., LOCATE OUTSIDE OF CROSSWALKS).
- IDENTIFY ALL SIGN AND POST LOCATIONS WITHIN THE GI AREA AND ENSURE PROPER BACKFILL MATERIALS ARE PRESENT TO PROVIDE THE NECESSARY STRUCTURAL SUPPORT.

DESIGNER CHECKLIST (MUST SPECIFY, AS APPLICABLE):

- SYSTEM WIDTH AND LENGTH
- DEPTH OF PONDING (IF APPLICABLE)
- DEPTH OF SYSTEM
- DEPTH AND TYPE OF AGGREGATE STORAGE
- SURFACE ELEVATION AT UPSLOPE AND DOWNSLOPE ENDS OF FACILITY
- DIMENSIONS AND DISTANCE TO EVERY MUNICIPAL SERVICE/UTILITY WITHIN 10m OF THE FACILITY
- ELEVATIONS OF EVERY INLET, OUTLET, STRUCTURE RIM AND INVERT.
- TYPE AND DESIGN OF COMPONENTS (E.G., EDGE TREATMENTS, INLETS/GUTTER MODIFICATIONS, UTILITY CROSSINGS, LINER, AND PLANTING DETAILS)

REV.	REVISION DATE	APPROVED

BIOSWALES
DESIGN NOTES AND GUIDANCE

ISSUE DATE: DECEMBER 2024
APPROVED BY: N. MEAD-FOX

BIOSWALE DRAWING DESCRIPTIONS

GI7.0A	BIOSWALE DESIGN NOTES AND GUIDANCE	THE BIOSWALE DESIGN NOTES PROVIDE GUIDANCE TO DESIGNERS ON HOW TO USE AND ADAPT THE TEMPLATE STANDARDS IN THIS SECTION.
GI7.0B	BIOSWALE DRAWING DESCRIPTIONS	THIS DRAWING DESCRIBES THE PURPOSE AND INTENDED USE OF EACH RAINWATER BIOSWALE DRAWING
GI7.1	BIOSWALE - NO ROAD DRAINAGE	GI7.1 IS FOR SYSTEMS THAT ONLY RECEIVE OVERLAND DRAINAGE FROM ADJACENT SIDEWALKS, BOULEVARDS, OR BIKE LANES. THIS SYSTEM SHOULD ONLY BE USED WHEN ROADWAY DRAINAGE CAPTURE IS DEEMED INFEASIBLE OR IF THE ALLOCATED BOULEVARD SPACE IS NOT SUFFICIENT TO ACCOMMODATE ROAD RUNOFF.
GI7.2	BIOSWALE - RECEIVING ROAD DRAINAGE	GI7.2 IS FOR BIOSWALES THAT RECEIVE OVERLAND DRAINAGE FROM THE ROADWAY THROUGH CURB CUTS AND FROM ADJACENT SIDEWALK, BOULEVARDS, OR BIKE LANES. THIS DESIGN IS PREFERRED TO GI7.1 BECAUSE IT CAN CAPTURE A LARGER DRAINAGE AREA AND USE THE FULL CAPACITY OF THE SWALE.

REV.	REVISION DATE	APPROVED

BIOSWALES
BIOSWALE DRAWING DESCRIPTIONS

ISSUE DATE: DECEMBER 2024

APPROVED BY: N. MEAD-FOX

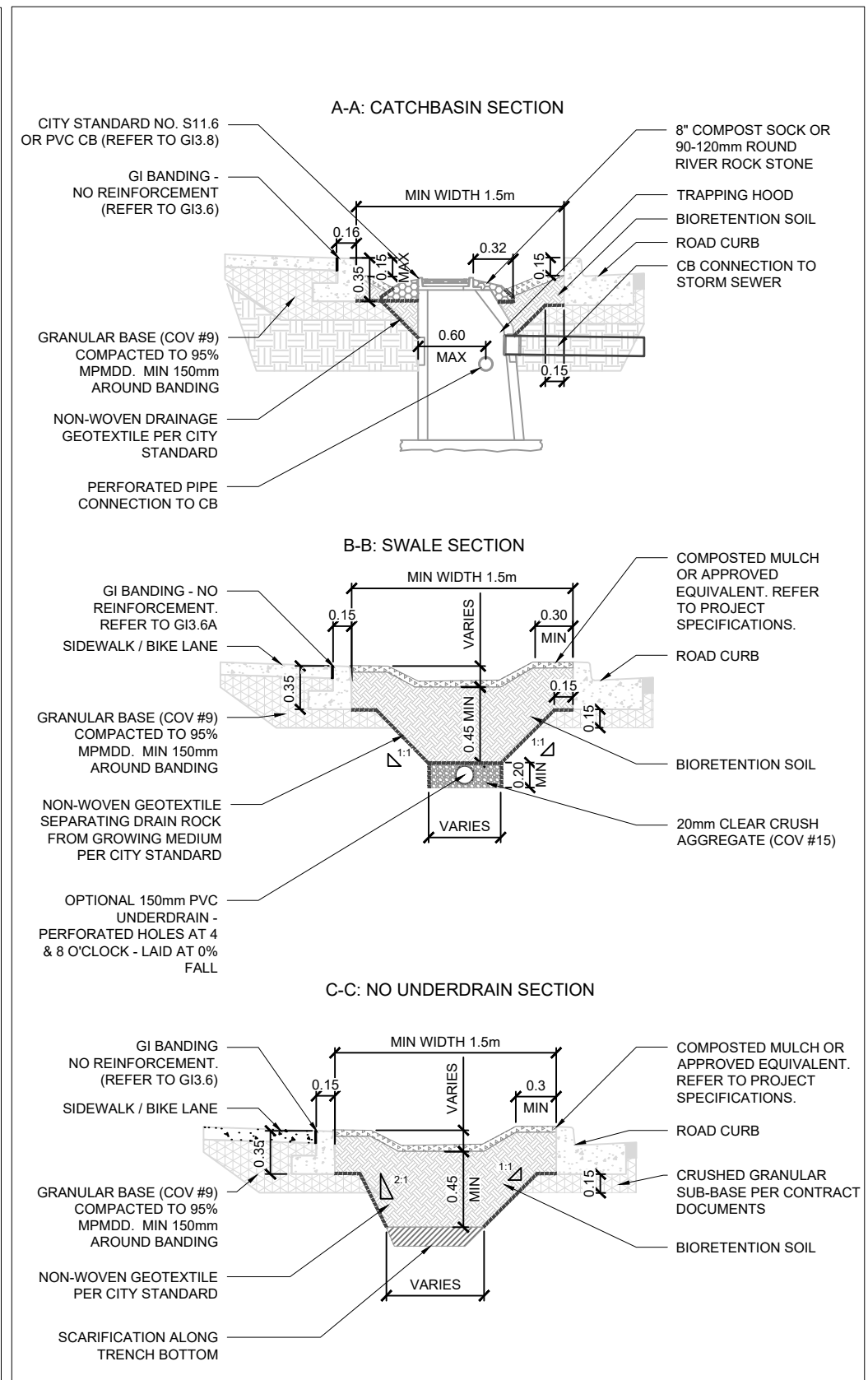
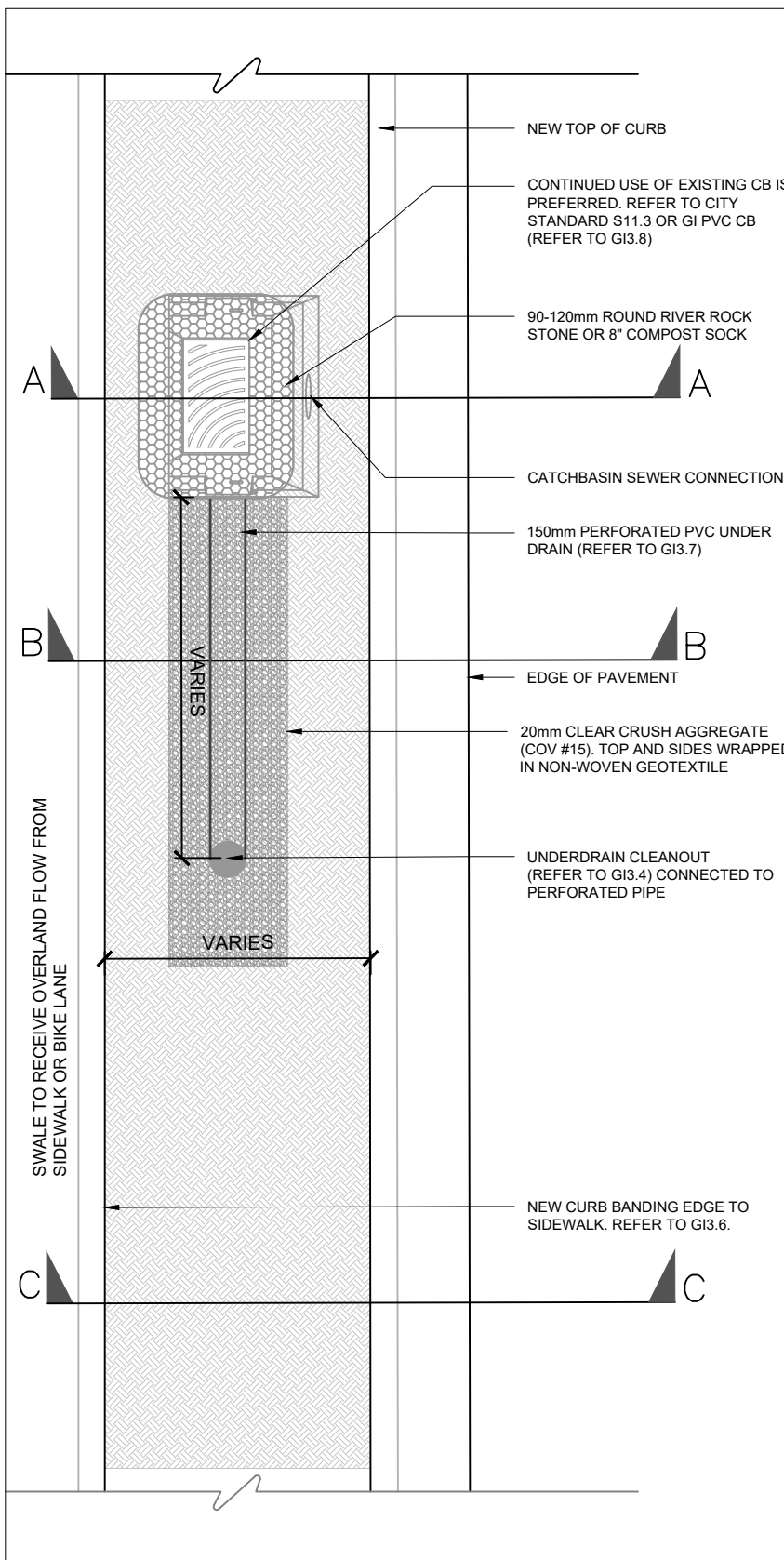
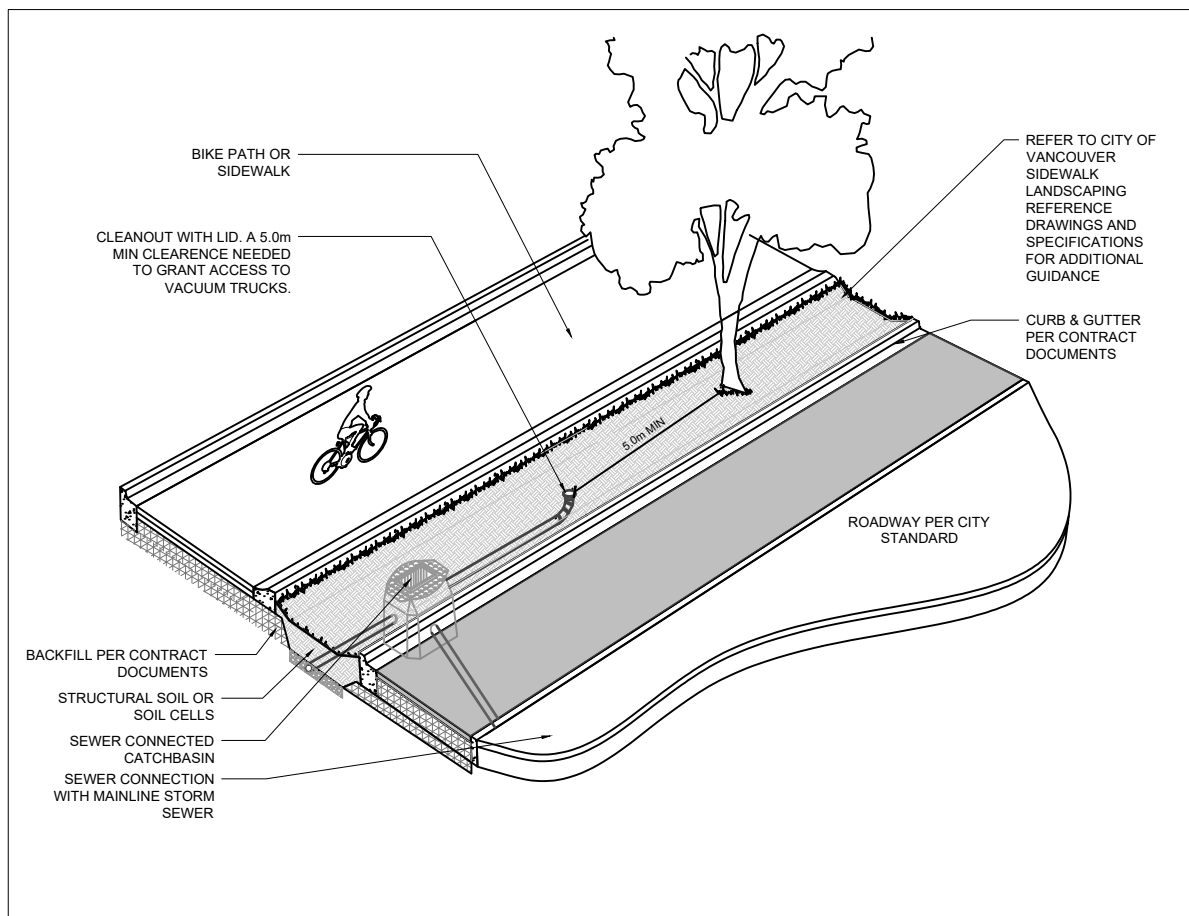

NOTES:

1. IF APPROVED BY PROJECT ENGINEER, CATCHBASINS MAY BE REPLACED WITH PVC CATCHBASINS (GI3.8)
2. LABEL AND DISPLAY ALL UTILITIES AND/OR SERVICES THAT CROSS BELOW OR THROUGH THE INFILTRATION TRENCH ALONG WITH THEIR INVERT ELEVATIONS
3. SHOW ALL UTILITY PROTECTION MEASURES AND SETBACKS FOR SERVICES AND/OR UTILITY CONFLICTS
4. PRE-SURVEY OF THE EXISTING CATCH BASIN (CB) CONDITIONS MUST BE CONDUCTED. THE PICTURES OF CBS (INSIDE AND OUTSIDE), WELL ORGANIZED AND CORRELATED WITH THE CB LOCATION, ARE SUFFICIENT.
5. CORE OPENING IN THE EXISTING CB WALL TO SUIT PVC PERFORATED PIPE CONNECTION. GROUT ANNULAR OPENING AROUND THE PIPE WITH NON-SHRINK GROUT.
6. COV REPRESENTATIVE (SEWER MAINTENANCE INSPECTOR) SHALL INSPECT AND APPROVE THE CONNECTION PRIOR TO THE PIPE BEING BURIED. PROVIDE AT LEAST 48 HOURS NOTIFICATION.

BIOSWALES
BIOSWALE - NO ROAD DRAINAGE

ISSUE DATE: FEBRUARY 2026
APPROVED BY: N. MEAD-FOX

REV.	REVISION DATE	APPROVED

BIOSWALE WITH UNDERDRAIN

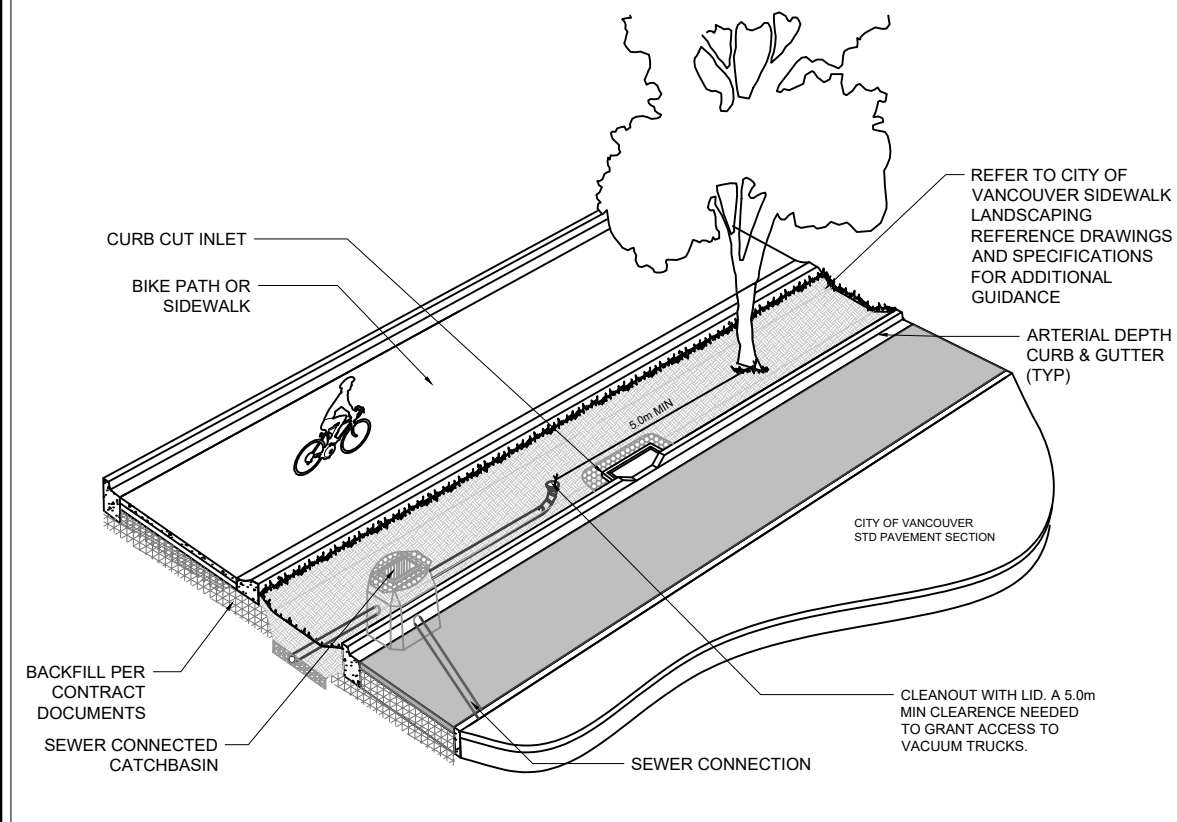

- NOTES:**
1. IF APPROVED BY PROJECT ENGINEER, CATCHBASINS MAY BE REPLACED WITH PVC CATCHBASINS (REFER TO GI3.8)
 2. LABEL AND DISPLAY ALL UTILITIES AND/OR SERVICES THAT CROSS BELOW OR THROUGH THE INFILTRATION TRENCH ALONG WITH THEIR INVERT ELEVATIONS
 3. SHOW ALL UTILITY PROTECTION MEASURES AND SETBACKS FOR SERVICES AND/OR UTILITY CONFLICTS
 4. PRE-SURVEY OF THE EXISTING CATCH BASIN (CB) CONDITIONS MUST BE CONDUCTED. THE PICTURES OF CBS (INSIDE AND OUTSIDE) , WELL ORGANIZED AND CORRELATED WITH THE CB LOCATION, ARE SUFFICIENT.
 5. CORE OPENING IN THE EXISTING CB WALL TO SUIT PVC PERFORATED PIPE CONNECTION. GROUT ANNULAR OPENING AROUND THE PIPE WITH NON-SHRINK GROUT.
 6. COV REPRESENTATIVE (SEWER MAINTENANCE INSPECTOR) SHALL INSPECT AND APPROVE THE CONNECTION PRIOR TO THE PIPE BEING BURIED. PROVIDE AT LEAST 48 HOURS NOTIFICATION.

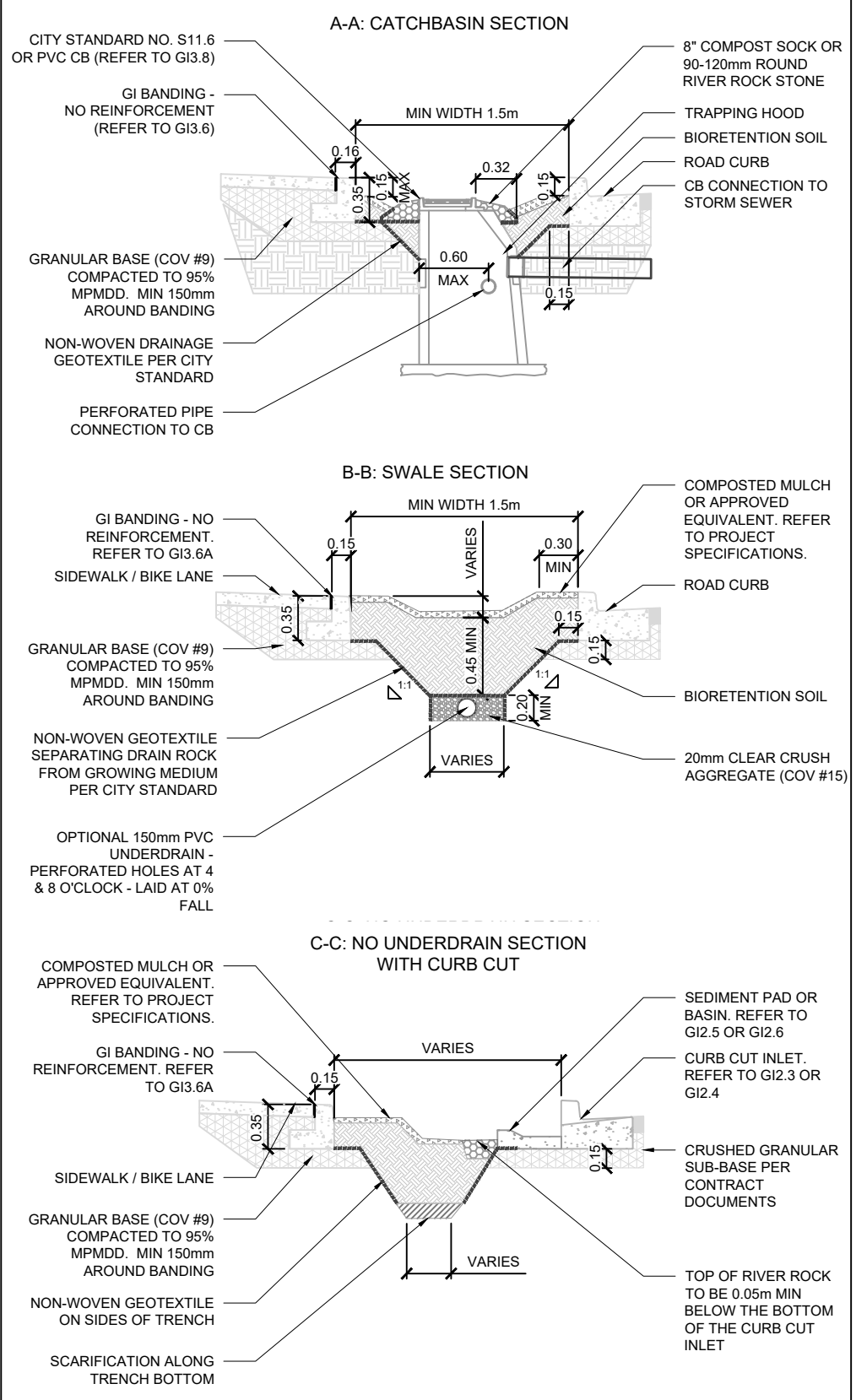
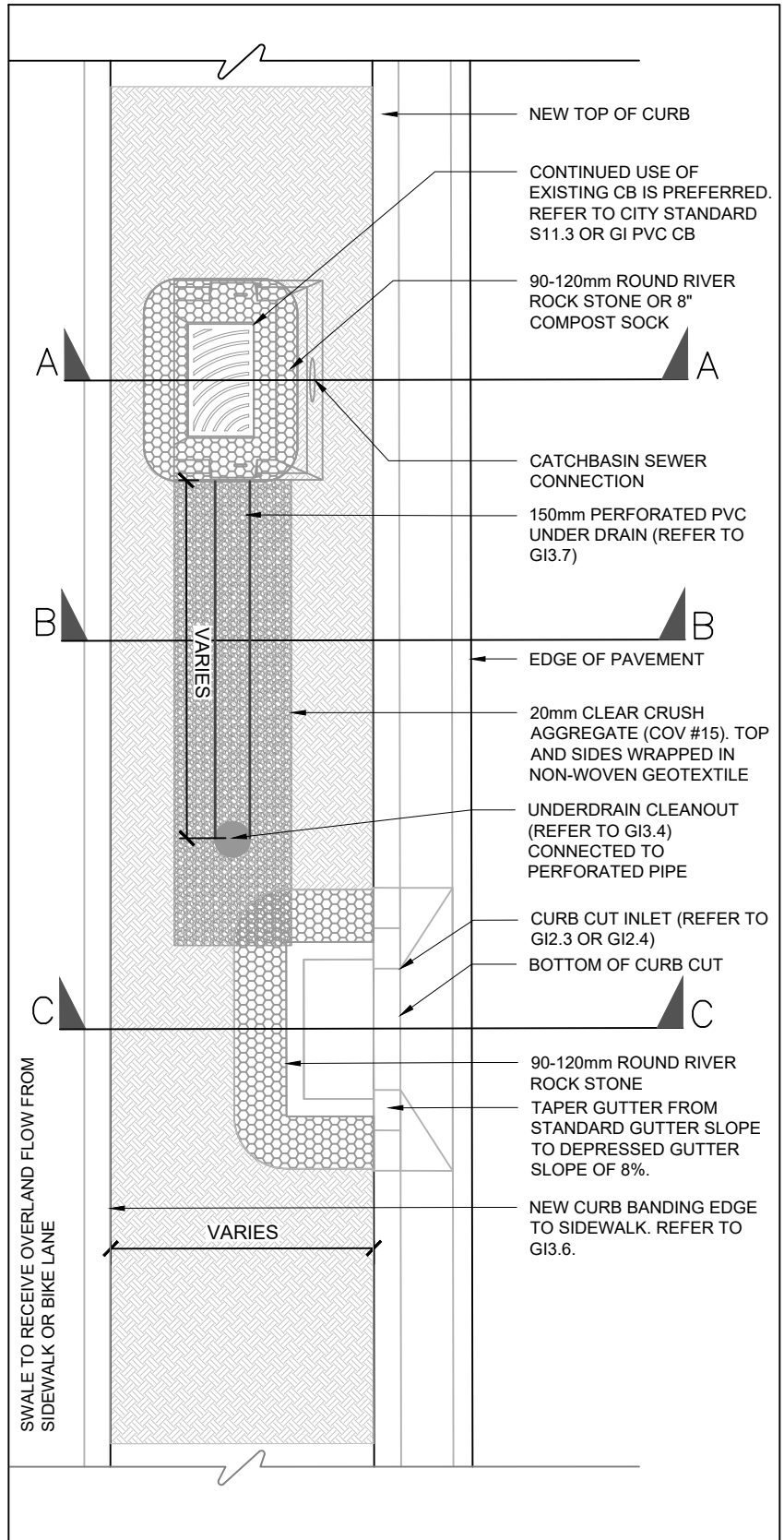

BIOSWALES
BIOSWALE - RECEIVING ROAD DRAINAGE

ISSUE DATE: FEBRUARY 2026
APPROVED BY: N. MEAD-FOX

REV.	REVISION DATE	APPROVED

PERMEABLE PAVEMENTS DESIGN NOTES AND GUIDANCE

PURPOSE:

INFILTRATION SYSTEMS RETAIN RAINWATER RUNOFF BY PROVIDING SURFACE STORAGE, SUBSURFACE STORAGE AND INFILTRATION INTO NATIVE SOIL. THE STORAGE IN INFILTRATION SYSTEMS CAN ALSO REDUCE THE PEAK FLOW ENTERING SEWERS AND REMOVE RAINWATER FROM ENTERING SEWERS.

DESIGNER NOTES & GUIDELINES:

1. THE DESIGNER MUST ADAPT PLAN AND SECTION DRAWINGS TO ADDRESS SITE-SPECIFIC CONDITIONS.
2. SYSTEM SURFACE AREA, PONDING DEPTH, SOIL DEPTH, AND AGGREGATE STORAGE DEPTH MUST BE SIZED TO MEET PROJECT HYDROLOGIC PERFORMANCE GOALS.
3. PONDING AND SYSTEM DRAWDOWN TIME (i.e., TIME FOR MAXIMUM SURFACE PONDING TO DRAIN THROUGH THE SYSTEM AFTER THE END OF A STORM) RECOMMENDATIONS:
 - 24 HOUR MAXIMUM SURFACE PONDING DRAWDOWN
 - 72 HOUR MAXIMUM DRAWDOWN FOR RTT SOIL AND AGGREGATE STORAGE
4. INFILTRATION SYSTEMS MAY BE DESIGNED USING AGGREGATE STORAGE OR PROPRIETARY STORAGE SYSTEMS. ALL PROPOSED PRODUCTS FOR USE IN RIGHT-OF-WAYS MUST MEET CITY OF VANCOUVER SPECIFICATIONS REGARDING LOADING CAPACITY OF RIGHT-OF-WAY INFRASTRUCTURE.
5. WHEN FACILITY CONSTRUCTION IMPACTS EXISTING SIDEWALK, ALL SAW CUTS MUST ADHERE TO CITY OF VANCOUVER REQUIREMENTS. SAW CUTS SHOULD BE ALONG SCORE LINES AND ANY DISTURBED SIDEWALK PANELS SHOULD BE REPLACED IN THEIR ENTIRETY.
6. GI FACILITIES IN PUBLIC RIGHT OF WAY SHALL BE DESIGNED WITH A SAFE, DESIGNATED OVERLAND FLOW PATH TO THE STREET IN THE EVENT THAT THE OVERFLOW STRUCTURE IS OBSTRUCTED OR CLOGGED. THIS FLOW PATH SHOULD BE REFLECTED IN SITE GRADING AND LABELED ON GI DRAWINGS.
7. THE DESIGNER MUST EVALUATE UTILITY SURVEYS FOR POTENTIAL UTILITY CROSSINGS OR CONFLICTS.
8. MINIMUM UTILITY SETBACKS AND PROTECTION MEASURES MUST CONFORM TO CURRENT CITY OF VANCOUVER ASSET PROTECTION STANDARDS AND OTHER UTILITY PROVIDER REQUIREMENTS.
9. DESIGN OF SUBSURFACE INFILTRATION FACILITIES MUST ALWAYS BE BASED ON SITE-SPECIFIC GEOTECHNICAL ANALYSIS AND MUST CONSIDER THE POTENTIAL IMPACT OF INCREASED INFILTRATION ON SURROUNDING INFRASTRUCTURE.

RELATED DETAILS	
EDGE TREATMENTS:	GI 3.5 - GI 3.6
INLETS:	GI 2.1 - GI 2.5
UNDERDRAINS:	GI 3.7
MONITORING WELL	GI 3.2
CLEANOUTS	GI 3.4
INSPECTION CHAMBERS	GI 3.3
CATCHBASINS	GI 3.1 - GI 3.8

RELATED SPECIFICATIONS	COV SPEC NO.
- AGGREGATE STORAGE	32 11 23S
- DRAINAGE FABRIC	31 32 20S
- LINERS	33 47 13.13
- ENGINEERED SOIL	32 91 22S

LAYOUT REQUIREMENTS:

1. REFER TO THE CITY OF VANCOUVER ACCESSIBILITY STRATEGY, STANDARD DRAWINGS AND CONSTRUCTION SPECIFICATIONS FOR RIGHT-OF-WAY, PARKING SPACE, AND ACCESSIBLE PATH REQUIREMENTS.
2. LOCATE CURB CUTS AND GUTTER MODIFICATIONS TO AVOID CONFLICTS WITH ACCESSIBILITY REQUIREMENTS (E.G., LOCATE OUTSIDE OF CROSSWALKS OR PARKING LAYBYS)

DESIGNER CHECKLIST (MUST SPECIFY, AS APPLICABLE):

- SYSTEM WIDTH AND LENGTH
- DEPTH OF PONDING (IF APPLICABLE)
- DEPTH OF SYSTEM
- DEPTH AND TYPE OF AGGREGATE STORAGE
- SURFACE ELEVATION AT UPSLOPE AND DOWNSLOPE ENDS OF FACILITY
- DIMENSIONS AND DISTANCE TO EVERY MUNICIPAL SERVICE/UTILITY WITHIN 10m OF THE FACILITY
- ELEVATIONS OF EVERY INLET, OUTLET, STRUCTURE RIM AND INVERT
- TYPE AND DESIGN OF COMPONENTS (E.G., EDGE TREATMENTS, INLETS/GUTTER MODIFICATIONS, UTILITY CROSSINGS, LINER, AND PLANTING DETAILS)

REV.	REVISION DATE	APPROVED

PERMEABLE PAVEMENTS
DESIGN NOTES AND GUIDANCE

ISSUE DATE: DECEMBER 2023
APPROVED BY: N. MEAD-FOX

PERMEABLE PAVEMENT SYSTEM DRAWING DESCRIPTIONS

GI8.0A	INFILTRATION SYSTEM DESIGN NOTES	THE SUB-SURFACE INFILTRATION SYSTEMS DESIGN NOTES PROVIDE GUIDANCE TO DESIGNERS ON HOW TO USE AND ADAPT THE TEMPLATE STANDARDS IN THIS SECTION.
GI8.0B	INFILTRATION SYSTEM DRAWING DESCRIPTIONS	THIS DRAWING DESCRIBES THE PURPOSE AND INTENDED USE OF EACH SUB-SURFACE INFILTRATION SYSTEM DRAWING.
GI8.1	RIGHT OF WAY INFILTRATION TRENCH	THIS STANDARD DEPICTS AN INFILTRATION TRENCH BENEATH A PORTION OF ROADWAY DIRECTLY ADJACENT TO A CURB. INFILTRATION TRENCHES ARE FUNCTIONALLY SIMILAR TO TREE TRENCHES BUT ARE DESIGNED UNDER HARDSCAPES. THEY REQUIRE CATCHBASINS TO DIRECT RUNOFF INTO PERFORATED DISTRIBUTION PIPES THAT DRAIN INTO THE VOIDS OF SUBSURFACE AGGREGATE. THE INFILTRATION AREA OF A TREE TRENCH IS OFTEN CONFINED TO MINIMIZE POTENTIAL IMPACTS ON SURROUNDING INFRASTRUCTURE.
GI6.2	RIGHT OF WAY DRY WELL	DRY WELLS DIRECT ROAD RUNOFF INTO A PERFORATED INSPECTION CHAMBER SURROUNDED BY LOOSE AGGREGATE. THESE SYSTEMS CAN ENCOURAGE INFILTRATION IN AREAS WHERE AN INFILTRATION TRENCH IS INFEASIBLE DUE TO SITE CONSTAINTS. OVERFLOW FROM DRY WELLS IS DIRECTED INTO CITY SEWERS.
GI6.3	BOULEVARD INFILTRATION TRENCH	THIS STANDARD DEPICTS AN INFILTRATION TRENCH BENEATH A BOULEVARD AREA. IT IS FUNCTIONALLY SIMILAR TO A ROADWAY INFILTRATION TRENCH BUT WITH ADDITIONAL OPTIONS FOR SUBSURFACE AGGREGATE AND IMPERMEABLE LINER USE.

REV.	REVISION DATE	APPROVED

**PERMEABLE PAVEMENTS
DRAWING DESCRIPTIONS**

ISSUE DATE: DECEMBER 2023
APPROVED BY: N. MEAD-FOX

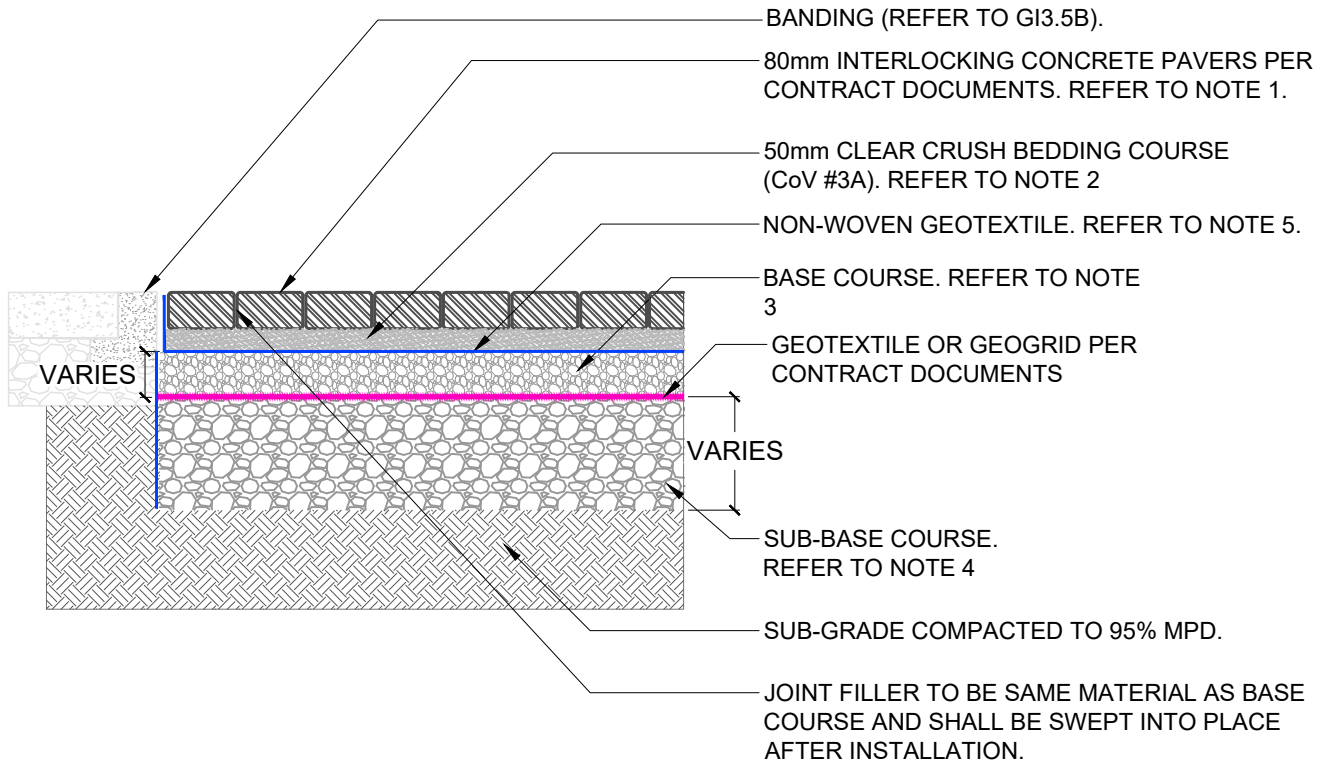

NOTES:

1. **PAVERS:** PAVERS TO BE ARRANGED IN A HERRINGBONE OR RUNNING BOND PATTERN. MATERIAL AND PLACEMENT PER CONTRACT DOCUMENTS. JOINT WIDTH BETWEEN PAVERS MUST BE GREATER THAN 6mm.
2. **BEDDING COURSE:** BEDDING COURSE AND JOINT FILLER TO BE ANGULAR CLEAR CRUSH (COV #3A, CSA A23.1 GROUP II 5-2.5 mm, ASTM NO. 8 STONE, OR AN APPROVED EQUIVALENT. BASE COURSE TO BE COMPACTED TO 95% MODIFIED PROCTOR OR AN APPROVED EQUIVALENT. MINIMUM THICKNESS OF 50mm.
3. **BASE MATERIAL:** BASE COURSE TO BE ASTM NO. 57 (CSA A23.1 GROUP II 28-14mm) OR 20mm CLEAR CRUSH (COV #15) OR AN APPROVED EQUIVALENT. MAXIMUM THICKNESS OF 300mm, MIN THICKNESS DEPENDS ON THE SIZE OF THE LARGEST AGGREGATE. IF 20mm CLEAR CRUSH IS USED, MINIMUM THICKNESS IS 60mm.
4. **SUB-BASE MATERIAL:** SUB-BASE RESERVOIR IS OPTIONAL IF THE EXISTING NATIVE SUBGRADE IS APPROVED BY THE GEOTECHNICAL ENGINEER. MINIMUM THICKNESS TO BE 225mm IF SUB-BASE LAYER IS REQUIRED. ADDITIONAL DEPTH TO BE DETERMINED BY GI DESIGN REQUIREMENTS. ACCEPTABLE MATERIALS INCLUDE 75mm CLEAR CRUSH, ASTM NO. 2, OR OTHER APPROVED EQUIVALENT. MAXIMUM THICKNESS OF 75mm MATERIAL IS 800mm.
6. **GEOMEMBRANE:** GEOMEMBRANE PER CONTRACT DOCUMENTS. GEOMEMBRANE EVERY 300mm WITHIN THE SUB-BASE LAYER IS RECOMMENDED.
7. **GEOTEXTILE FABRIC LAYER:** A NON-WOVEN GEOTEXTILE MUST BE INSTALLED BENEATH THE BEDDING COURSE AND ON THE SIDES OF THE EXCAVATION AREA. ADDITIONAL NON-WOVEN GEOTEXTILE PER CONTRACT DOCUMENTS.
8. ALL DIMENSIONS IN MILLIMETERS UNLESS STATED OTHERWISE.
9. PERMEABLE PAVERS MAY ONLY BE INSTALLED IN PLAZAS OR FRONT BOULEVARDS OUTSIDE OF BUS LANDING AREAS UNLESS APPROVAL IS GRANTED BY STREETS DESIGN STAFF.

REV.	REVISION DATE	APPROVED

PERMEABLE PAVEMENTS
PERMEABLE CONCRETE PAVERS

ISSUE DATE: DECEMBER 2023
APPROVED BY: N. MEAD-FOX

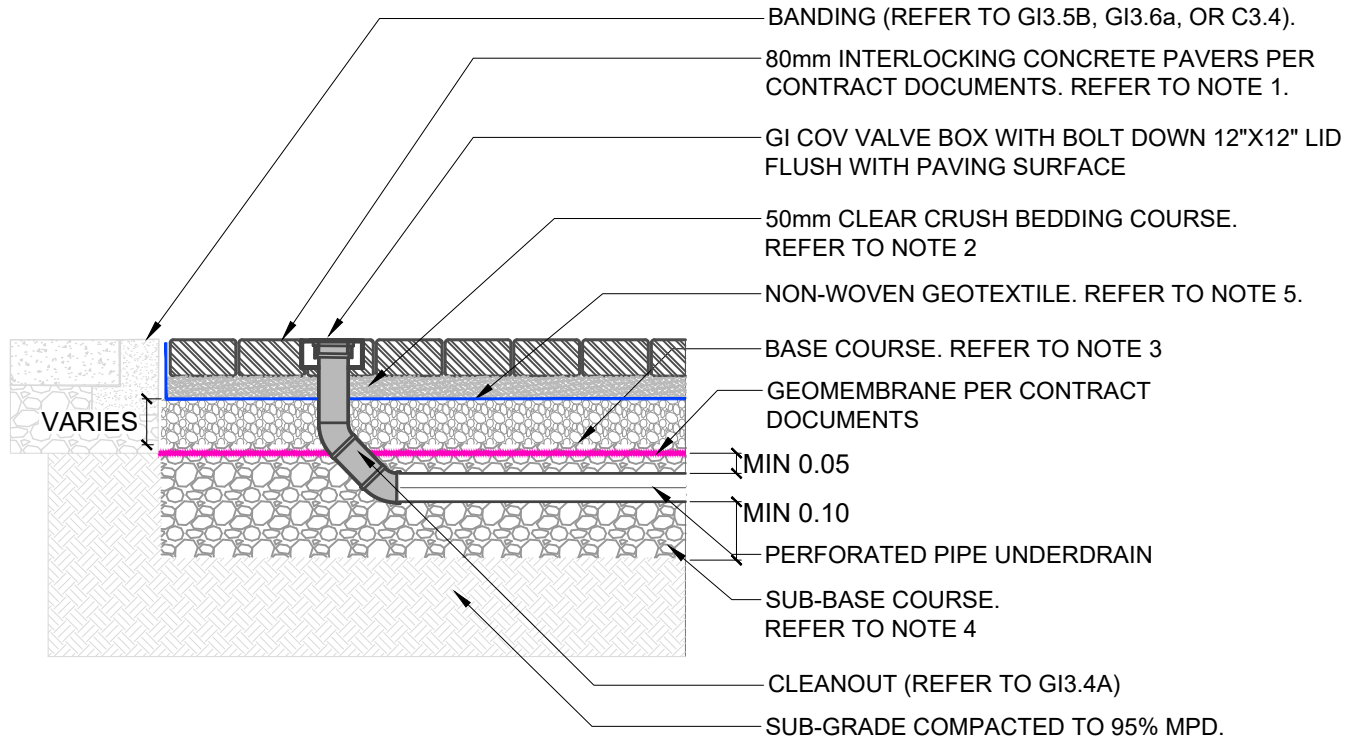

PERFORATED PIPE UNDERDRAIN

DIMPLE BOARD - ZIP EVERY 3m TO PIPE TO PREVENT SOIL FROM FALLING INTO PIPE

WRAP PERFORATED PIPE WITH NON-WOVEN GEOTEXTILE

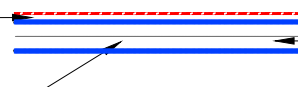

SUBDRAIN PIPE:
150mm PVC PERFORATED PIPE, LAID W/ 0% SLOPE. BOTTOM TO BE PERFORATED, HOLES AT 4 AND 8 O'CLOCK.

NOTES:

1. **PAVERS:** PAVERS TO BE ARRANGED IN A HERRINGBONE OR RUNNING BOND PATTERN. MATERIAL AND PLACEMENT PER CONTRACT DOCUMENTS. JOINT WIDTH BETWEEN PAVERS MUST BE GREATER THAN 6mm.
2. **BEDDING COURSE:** ANGULAR CLEAR CRUSH (COV #3A) COMPACTED TO 95% MODIFIED PROCTOR. MINIMUM THICKNESS OF 50mm. BEDDING COURSE MATERIAL TO BE USED AS JOINT FILLER
3. **BASE MATERIAL:** BASE COURSE TO BE ASTM NO. 57 (CSA A23.1 GROUP II 28-14mm) OR 20mm CLEAR CRUSH (COV #15) OR AN APPROVED EQUIVALENT. MAXIMUM THICKNESS OF 300mm, MIN THICKNESS DEPENDS ON THE SIZE OF THE LARGEST AGGREGATE. IF 20mm CLEAR CRUSH IS USED, MINIMUM THICKNESS IS 60mm.
4. **SUB-BASE MATERIAL:** SUB-BASE RESERVOIR IS OPTIONAL IF THE EXISTING NATIVE SUBGRADE IS APPROVED BY THE GEOTECHNICAL ENGINEER. MINIMUM THICKNESS TO BE 225mm IF SUB-BASE LAYER IS REQUIRED. ADDITIONAL DEPTH TO BE DETERMINED BY GI DESIGN REQUIREMENTS. ACCEPTABLE MATERIALS INCLUDE 75mm CLEAR CRUSH, ASTM NO. 2, OR OTHER APPROVED EQUIVALENT. MAXIMUM THICKNESS OF 75mm MATERIAL IS 800mm.
6. **GEOMEMBRANE:** GEOMEMBRANE PER CONTRACT DOCUMENTS. GEOMEMBRANE EVERY 300mm WITHIN THE SUB-BASE LAYER IS RECOMMENDED.
7. **GEOTEXTILE FABRIC LAYER:** A NON-WOVEN GEOTEXTILE MUST BE INSTALLED BENEATH THE BEDDING COURSE AND ON THE SIDES OF THE EXCAVATION AREA. ADDITIONAL NON-WOVEN GEOTEXTILE PER CONTRACT DOCUMENTS.
8. ALL DIMENSIONS IN MILLIMETERS UNLESS STATED OTHERWISE.

REV.	REVISION DATE	APPROVED

PERMEABLE PAVEMENTS
PERMEABLE PAVERS WITH UNDERDRAIN

ISSUE DATE: DECEMBER 2023

APPROVED BY: N. MEAD-FOX

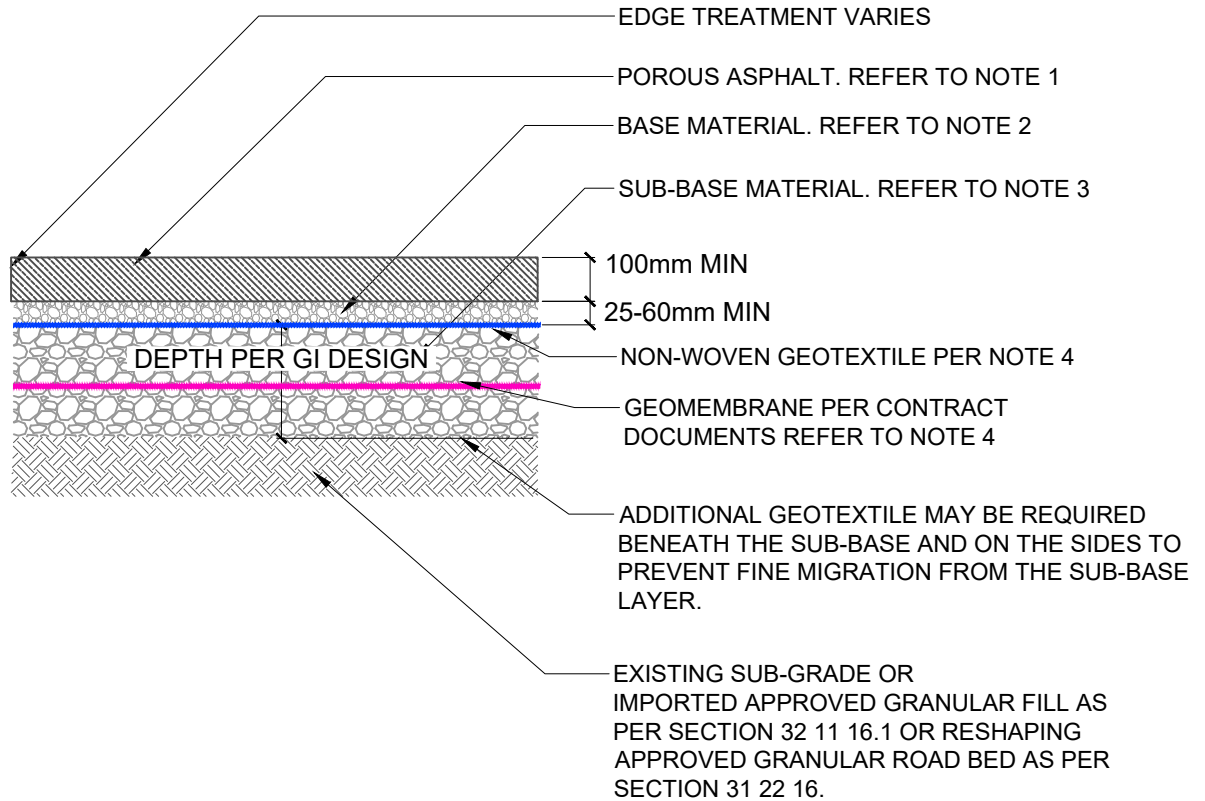

NOTES:

1. **POROUS ASPHALT:** 100mm MIN. MATERIAL PER CONTRACT DOCUMENTS
3. **BASE MATERIAL:** BASE COURSE TO BE ASTM NO. 57 (CSA A23.1 GROUP II 28-14mm) OR 20mm CLEAR CRUSH (COV #15) OR AN APPROVED EQUIVALENT. MAXIMUM THICKNESS OF 300mm, MIN THICKNESS DEPENDS ON THE SIZE OF THE LARGEST AGGREGATE. IF 20mm CLEAR CRUSH IS USED, MINIMUM THICKNESS IS 60mm.
4. **SUB-BASE MATERIAL:** SUB-BASE RESERVOIR IS OPTIONAL IF THE EXISTING NATIVE SUBGRADE IS APPROVED BY THE GEOTECHNICAL ENGINEER. MINIMUM THICKNESS TO BE 225mm IF SUB-BASE LAYER IS REQUIRED. ADDITIONAL DEPTH TO BE DETERMINED BY GI DESIGN REQUIREMENTS. ACCEPTABLE MATERIALS INCLUDE 75mm CLEAR CRUSH, ASTM NO. 2, OR OTHER APPROVED EQUIVALENT. MAXIMUM THICKNESS OF 75mm MATERIAL IS 800mm.
7. **GEOTEXTILE FABRIC LAYER:** A NON-WOVEN GEOTEXTILE MUST BE INSTALLED BENEATH THE BEDDING COURSE AND ON THE SIDES OF THE EXCAVATION AREA. ADDITIONAL NON-WOVEN GEOTEXTILE PER CONTRACT DOCUMENTS.
8. **GEOMEMBRANE:** GEOMEMBRANE PER CONTRACT DOCUMENTS. GEOMEMBRANE EVERY 300mm WITHIN THE SUB-BASE LAYER IS RECOMMENDED.
9. **EDGE TREATMENT:** CONCRETE EDGE TREATMENT IS REQUIRED AT THE BOUNDARY OF ALL BIKELANES. REFER TO GI3.5B.
10. ALL DIMENSIONS IN MILLIMETERS UNLESS STATED OTHERWISE.

REV.	REVISION DATE	APPROVED

PERMEABLE PAVEMENTS
POROUS ASPHALT BIKELANE

ISSUE DATE: DECEMBER 2023
APPROVED BY: N. MEAD-FOX

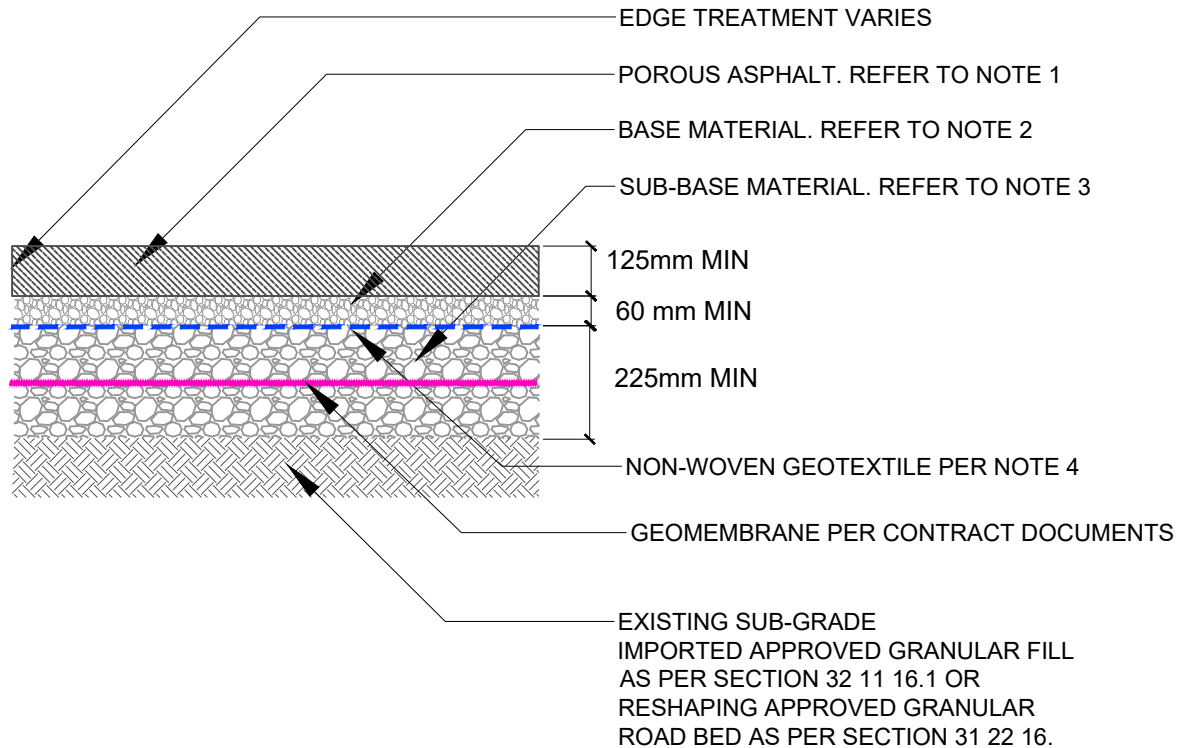

NOTES:

1. **POROUS ASPHALT:** 125mm MIN. MATERIAL OR PER CONTRACT DOCUMENTS
3. **BASE MATERIAL:** BASE COURSE TO BE ASTM NO. 57 (CSA A23.1 GROUP II 28-14mm) OR 20mm CLEAR CRUSH (COV #15) OR AN APPROVED EQUIVALENT. MAXIMUM THICKNESS OF 300mm, MIN THICKNESS DEPENDS ON THE SIZE OF THE LARGEST AGGREGATE. IF 20mm CLEAR CRUSH IS USED, MINIMUM THICKNESS IS 60mm.
4. **SUB-BASE MATERIAL:** SUB-BASE RESERVOIR IS OPTIONAL IF THE EXISTING NATIVE SUBGRADE IS APPROVED BY THE GEOTECHNICAL ENGINEER. MINIMUM THICKNESS TO BE 225mm IF SUB-BASE LAYER IS REQUIRED. ADDITIONAL DEPTH TO BE DETERMINED BY GI DESIGN REQUIREMENTS. ACCEPTABLE MATERIALS INCLUDE 75mm CLEAR CRUSH, ASTM NO. 2, OR OTHER APPROVED EQUIVALENT. MAXIMUM THICKNESS OF 75mm MATERIAL IS 800mm.
7. **GEOTEXTILE FABRIC LAYER:** A NON-WOVEN GEOTEXTILE MUST BE INSTALLED BENEATH THE BEDDING COURSE AND ON THE SIDES OF THE EXCAVATION AREA. ADDITIONAL NON-WOVEN GEOTEXTILE PER CONTRACT DOCUMENTS.
8. **GEOMEMBRANE:** GEOMEMBRANE PER CONTRACT DOCUMENTS. GEOMEMBRANE EVERY 300mm WITHIN THE SUB-BASE LAYER IS RECOMMENDED.
9. **EDGE TREATMENT:** CONCRETE EDGE TREATMENT IS REQUIRED AT THE BOUNDARY OF ALL BIKELANES. REFER TO GI3.5B.
10. ALL DIMENSIONS IN MILLIMETERS UNLESS STATED OTHERWISE.

REV.	REVISION DATE	APPROVED

PERMEABLE PAVEMENTS
POROUS ASPHALT LANEWAY

ISSUE DATE: DECEMBER 2023
APPROVED BY: N. MEAD-FOX

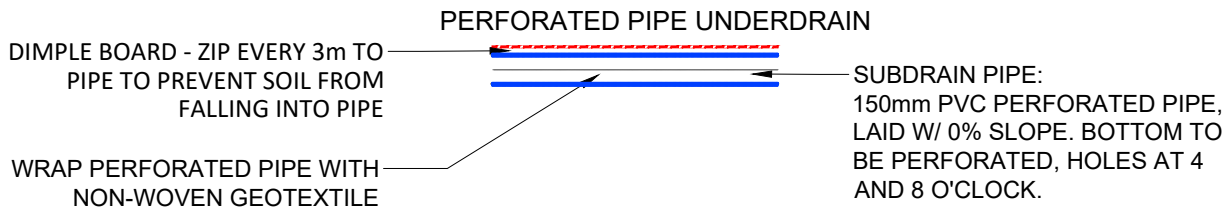
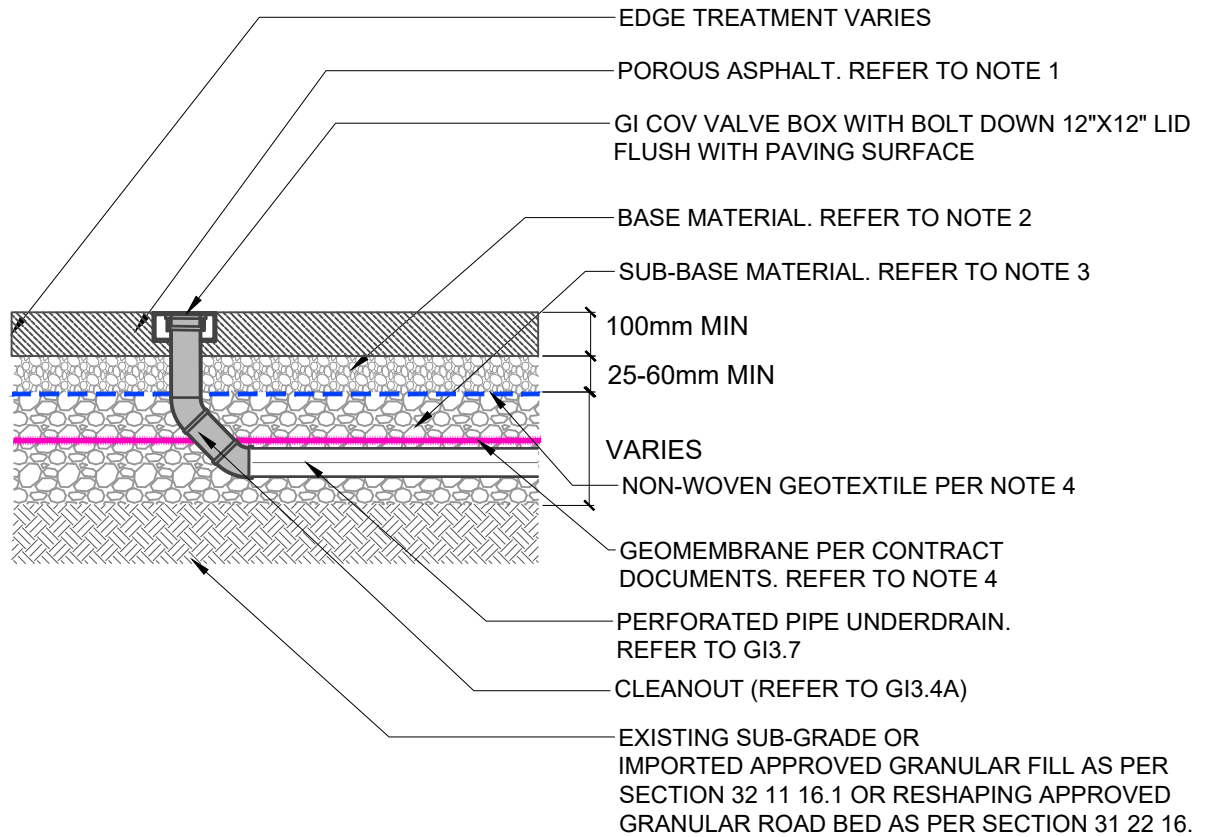

NOTES:

1. **POROUS ASPHALT:** 100mm MIN. MATERIAL PER CONTRACT DOCUMENTS
3. **BASE MATERIAL:** BASE COURSE TO BE ASTM NO. 57 (CSA A23.1 GROUP II 28-14mm) OR 20mm CLEAR CRUSH (COV #15) OR AN APPROVED EQUIVALENT. MAXIMUM THICKNESS OF 300mm, MIN THICKNESS DEPENDS ON THE SIZE OF THE LARGEST AGGREGATE. IF 20mm CLEAR CRUSH IS USED, MINIMUM THICKNESS IS 60mm.
4. **SUB-BASE MATERIAL:** SUB-BASE RESERVOIR IS OPTIONAL IF THE EXISTING NATIVE SUBGRADE IS APPROVED BY THE GEOTECHNICAL ENGINEER. MINIMUM THICKNESS TO BE 225mm IF SUB-BASE LAYER IS REQUIRED. ADDITIONAL DEPTH TO BE DETERMINED BY GI DESIGN REQUIREMENTS. ACCEPTABLE MATERIALS INCLUDE 75mm CLEAR CRUSH, ASTM NO. 2, OR OTHER APPROVED EQUIVALENT. MAXIMUM THICKNESS OF 75mm MATERIAL IS 800mm.
7. **GEOTEXTILE FABRIC LAYER:** A NON-WOVEN GEOTEXTILE MUST BE INSTALLED BENEATH THE BEDDING COURSE AND ON THE SIDES OF THE EXCAVATION AREA. ADDITIONAL NON-WOVEN GEOTEXTILE PER CONTRACT DOCUMENTS.
8. **GEOMEMBRANE:** GEOMEMBRANE PER CONTRACT DOCUMENTS. GEOMEMBRANE EVERY 300mm WITHIN THE SUB-BASE LAYER IS RECOMMENDED.
9. **EDGE TREATMENT:** CONCRETE EDGE TREATMENT IS REQUIRED AT THE BOUNDARY OF ALL BIKELANES. REFER TO GI3.5B.
10. ALL DIMENSIONS IN MILLIMETERS UNLESS STATED OTHERWISE.

REV.	REVISION DATE	APPROVED

PERMEABLE PAVEMENTS
POROUS ASPHALT WITH UNDERDRAIN

ISSUE DATE: DECEMBER 2023

APPROVED BY: N. MEAD-FOX